

PLEASE READ

Please check the A page for change information.

Since Hill-Rom Air-Shields conducts a continuous product improvement program, circuit and component improvements are sometimes incorporated into equipment before they can be incorporated into the printed manuals. When this occurs, changed material is provided on separate sheets at the rear of the manual or under separate cover in the form of a change package. Changed material on each page of text is indicated by a vertical bar in the margin next to the changed material, as shown on the right.

THIS MANUAL CONTAINS PROPRIETARY INFORMATION. REPAIRS AND AUTHORIZED MODIFICATIONS SHOULD BE PERFORMED ONLY BY QUALIFIED SERVICE PERSONNEL TO MAINTAIN YOUR WARRANTY AND TO AVOID CREATING SAFETY HAZARDS. WE CANNOT ASSUME RESPONSIBILITY FOR ANY CONDITIONS AFFECTING THE PROPER OPERATION OF THIS EQUIPMENT WHICH MAY RESULT FROM UNAUTHORIZED REPAIR OR MODIFICATION.

NOTE ON REPLACEMENT PARTS

Some parts used in your equipment may be different than those which appear in the Parts List of this manual. This sometimes occurs due to difficulty in parts procurement, but does not alter the function of the equipment. Order the part listed in the Parts List. Refer to Section 6 of this Manual for a listing of recommended spare parts.

NOTE: ALSO SEE PAGE 2.

LIST OF AVAILABLE MODIFICATION KITS

ITEM	DESCRIPTION AND PURPOSE	PART NO.
1	Filter Cover Knob/Retainer Replacement Kit	68 901 15
2	Deck Retainer Replacement Kit	68 901 22
3	Cable Assy Retrofit Kit. Provides Replacement Cable for AC Entry Board to Heater Board	68 908 00
4	ALL NON-ENGLISH, NON-120V UNITS Firmware Level 1.8 Eprom for 1 Incubator US/CANADIAN UNITS ONLY Firmware Level 1.8 US Eprom for 1 Incubator	68 908 11 68 908 16
5	Pneumatic Tilt Lock-Up. Provides Incubators with a mechanism that prevents the mattress from locking up when pneumatically tilted fully into the Trendelenburg or Reverse Trendelenburg position. In addition, it allows the mattress to be locked into either tilt when the pneumatic tilts is disabled.	68 901 23
6	Controller Grounding Spring. Moves Controller Grounding Spring from top of Controller opening to the bottom of the opening.	68 901 25
7	Firmware Level 1.9 120V, English Units only Firmware Level 1.9, All Non-English, Non-120V Units	68 908 16 68 908 11
8	Right and Left Hood Baffles Replacement Kit	68 901 46
9	Hoods without Stops-High and Baffles with Stops High Hood with Three Access Doors and One Iris Port Replacement Kit High Hood with Two Access Doors and Two Iris Ports Replacement Kit	68 901 48 68 901 48

Change 4

LIST OF EFFECTIVE PAGES

PAGE NO.	CHANGE	PAGE
Front Cover	7	11/99
Warranty Page	7	11/99
1	7	11/99
2	4	6/94
A through D	7	11/99
i through iii	2	8/93
iv	6	8/96
v	5	3/95
vi	4	6/94
vii	5	3/95
viii through xii	4	6/94
1-1 and 1-2	4	6/94
1-3	0	5/92
1-4 through 1-7	4	6/94
1-8	5	3/95
2-1 through 2-8	0	5/92
2-2	5	3/95
2-3	0	5/92
2-4	5	3/95
2-5 through 2-8	0	5/92
2-9	3	12/93
2-10 through 2-13	2	8/93
2-14	3	12/93
2-15 through 2-22	2	8/93
2-23 and 2-24	4	6/94
2-25 and 2-26	2	8/93
3-1	2	8/93
3-2 and 3-3	5	3/95
3-4 and 3-5	0	5/92
3-6	4	6/94
3-7	1	2/93
3-8 and 3-9	0	5/92
3-10	5	3/95
3-11 through 3-19	0	5/92

LIST OF EFFECTIVE PAGES (cont.)

PAGE NO.	CHANGE	PAGE
3-20	5	3/95
3-21A	6	8/96
3-21B	5	3/95
3-22	0	5/92
3-23	6	8/96
3-24	4	6/94
3-25	2	8/93
3-26	0	5/92
3-27	1	2/93
3-28 through 3-31	0	5/92
3-32 through 3-36	2	8/93
4-1	7	11/99
4-2 and 4-3	0	5/92
4-4	1	2/93
4-5	0	5/92
4-6 through 4-8	7	11/99
4-9	1	2/93
4-10	0	5/92
4-11 and 4-12	7	11/99
5-1 through 5-36	0	5/92
5-37 and 5-38	1	2/93
5-39 and 5-40	0	5/92
5-41	6	8/96
5-42 through 5-48	0	5/92
5-49	1	2/93
5-50	2	8/93
5-51	1	2/93
5-52	4	6/94
5-53 through 5-56	0	5/92
5-57	1	2/93
5-58 through 5-62	0	5/92
5-63 through 5-65	1	2/93
5-66	0	5/92
6-1	2	8/93

B

Change 7

LIST OF EFFECTIVE PAGES (cont.)

PAGE NO.	CHANGE	PAGE
6-2	4	6/94
6-3	5	3/95
6-3A and 6-3B	6	8/96
6-4	0	5/92
6-5 and 6-6	4	6/94
6-7	7	11/99
6-8	6	8/96
6-9 through 6-11	7	11/99
6-12 and 6-13	0	5/92
6-14	2	8/93
6-15 through 6-18	0	5/92
6-19	2	8/93
6-20	0	5/92
6-21 and 6-22	1	2/93
6-23	6	8/96
6-24	0	5/92
6-25	7	11/99
6-26 and 6-27	6	8/96
6-28	0	5/92
6-29	6	8/96
6-30 and 6-31	4	6/94
6-32	6	8/96
6-33	5	3/95
6-34	6	8/96
6-35	0	5/92
6-36	1	2/93
6-37	6	8/96
6-38	0	5/92
6-39	5	3/95
6-40	1	2/93
6-41	6	8/96
6-42	0	5/92
6-43	1	2/93
6-44	0	5/92

LIST OF EFFECTIVE PAGES (cont.)

PAGE NO.	CHANGE	PAGE
6-45	4	6/94
6-46 and 6-47	1	2/93
6-48 and 6-49	0	5/92
6-50 and 6-51	5	3/95
6-52 through 6-55	0	5/92
6-56 and 6-57	5	3/95
6-58	6	8/96
6-59	4	6/94
6-60	6	8/96
6-61	7	11/99
6-62	4	6/94
6-63	7	11/99
6-64 through 6-68	4	6/94
6-69	7	11/99
6-70	4	6/94
6-71	5	3/95
6-72 through 6-75	4	6/94
6-76	6	8/96
6-77	5	3/95
6-78	4	6/94
7-1 and 7-2	0	5/92
7-3	1	2/93
7-4	3	12/93
7-4A and 7-5	1	2/93
7-6 and 7-7	3	12/93
7-8	1	2/93
7-9 and 7-10	0	5/92

TABLE OF CONTENTS

SECTION	PAGE
SECTION 1	
GENERAL INFORMATION	1-1
1.1 INTRODUCTION	1-1
1.2 DESCRIPTION	1-1
1.2.1 ISOLETTE® INFANT INCUBATOR, MODEL C500	1-1
1.2.2 ISOLETTE® INFANT INCUBATOR, MODEL C550	1-1
1.3 ACCESSORIES	1-1
1.4 MODEL IDENTIFICATION SERIES CHANGE	1-4
SECTION 2	
INSTALLATION	2-1
2.1 UNPACKING	2-1
2.2 ASSEMBLY-INCUBATORS EQUIPPED WITH STANDARD CABINET STAND	2-1
2.3 ASSEMBLY-INCUBATORS EQUIPPED WITH OPTIONAL VERTICAL HEIGHT ADJUSTABLE STAND	2-3
2.4 INSTALLATION OF THE MATTRESS TILT BELLOWS	2-5
2.5 WARM WEIGH® INFANT SCALE, MODEL I20 (ACCESSORY)	2-7
2.6 CONFIGURING THE INCUBATOR	2-9
2.6.1 PROCEDURAL SILENCE TIME	2-9
2.6.2 KEYPAD LOCK TIME DURATION	2-9
2.6.3 AUDIO TONE	2-9
2.6.4 INCUBATOR NUMBER	2-9
2.6.5 RESTORING FACTORY DEFAULTS	2-9
2.6.6 NO EXTERNAL INTERFACE	2-10
2.6.7 CONFIGURING FOR A REMOTE MONITOR	2-10
2.6.8 CONFIGURING FOR A THERMAL PRINTER	2-11
2.6.9 CONFIGURING FOR A DOT MATRIX PRINTER	2-13
2.6.10 DISABLING THE BABY MODE FUNCTION (C550 CONTROLLERS ONLY)	2-14
2.6.11 LANGUAGE SELECTION	2-14
2.7 OPERATIONAL CHECKOUT PROCEDURE	2-15
2.7.1 CHECKING THE POWER FAILURE ALARM AND CONNECTING THE INCUBATOR TO THE AC LINE	2-15
2.7.2 OPERATIONAL CHECKOUT - HOOD/SHELL AND VHA STAND, IF SO EQUIPPED	2-17
2.7.3 OPERATIONAL CHECKOUT - CONTROLLER	2-23
SECTION 3	
TECHNICAL INFORMATION	3-1
3.1 SPECIFICATIONS	3-1
3.2 THE CONTROLLER MESSAGE CENTER	3-4
3.2.1 ALPHABETICAL LISTING OF ALARM, SYSTEM AND USER PROMPT MESSAGES ALONG WITH PAGE NUMBERS	3-4
3.2.2 ALARM MESSAGES	3-6
3.2.3 SYSTEM AND USER PROMPT MESSAGES	3-9
3.3 THEORY OF OPERATION	3-20
3.3.1 GENERAL	3-20
3.3.2 OVERALL FUNCTIONAL DESCRIPTION	3-20
3.3.3 AIR TEMPERATURE MODE	3-23

TABLE OF CONTENTS (continued)

SECTION	PAGE
3.3.4 BABY TEMPERATURE MODE	3-23
3.3.5 ALARMS	3-23
3.4 DETAILED CIRCUIT DESCRIPTION	3-27
3.4.1 AC ENTRY BOARD (REFER TO FIGURE 7.3)	3-27
GENERAL	3-27
AC MAINS INPUT	3-27
DC CIRCUIT	3-27
3.4.2 HEATER BOARD (REFER TO FIGURE 7.4)	3-27
AC LINE MONITORING	3-27
DC MOTOR CONTROL	3-27
POWER OK CIRCUITRY	3-28
AC OK CIRCUITRY	3-28
OVERHEAT DETECTION	3-28
3.4.3 MAIN BOARD (REFER TO FIGURE 7.5)	3-28
GENERAL	3-28
POWER SUPPLY	3-28
AC ENTRY	3-28
DC SUPPLY	3-28
MICRO-CONTROLLER	3-28
GENERAL	3-28
DATA BUS	3-29
ADDRESS BUS	3-29
CONTROL LINES	3-29
PORT A	3-29
PORT G	3-29
SERIAL COMMUNICATIONS	3-29
A/D CONVERTER	3-29
SUPPLY VOLTAGE	3-30
INTERNAL OPERATION MODES	3-30
DATA BUS PERIPHERALS	3-30
BUFFERS	3-30
TEMPERATURE INPUTS	3-30
HYBRIDS	3-30
PROBES	3-32
AUXILIARY TEMPERATURE	3-32
DUAL AIR	3-32
SKIN	3-32
AIR FLOW	3-32
INTERFACE CIRCUITS	3-32
DISPLAY BOARD	3-32
HEATER BOARD	3-33
SERIAL COMMUNICATIONS	3-33
MULTI-PURPOSE OUTPUT	3-34
ALARM LOGIC	3-34
GENERAL TIMING	3-34
ALARMS	3-34

Change 2

TABLE OF CONTENTS (continued)

SECTION	PAGE
3.4.4 DISPLAY BOARD (REFER TO FIGURE AND 7.6)	3-34
GENERAL	3-34
POWER SUPPLY	3-35
BATTERY SUPPLY	3-35
ELECTRICAL SPECIFICATIONS:	3-35
CHARGING CIRCUIT	3-35
DISPLAY DRIVERS	3-35
DISPLAYS	3-36
KEYBOARD INTERFACE	3-36
FAULT DETECTION LOGIC	3-36
SECTION 4	
PREVENTIVE MAINTENANCE	4-1
4.1 GENERAL	4-1
4.2 CLEANING	4-1
4.2.1 DIASSEMBLY FOR CLEANING	4-1
4.2.2 CLEANING	4-6
4.2.3 REASSEMBLY AFTER CLEANING	4-8
4.3 GAS STERILIZATION	4-12
SECTION 5	
SERVICE	5-1
5.1 GENERAL	5-1
5.2 THE DIAGNOSTIC MENU	5-1
THE CONFIGURATION MENU	5-1
THE SYSTEM INFORMATION MENU	5-1
THE TEST SYSTEM MENU	5-1
5.3 THE CONFIGURATION MENU	5-3
5.3.1 SELECTING THE CONFIGURATION MENU	5-3
5.3.2 SETTING THE PROCEDURAL SILENCE TIME	5-4
5.3.3 SETTING THE KEYPAD TIME-TO-LOCK TIME	5-6
5.3.4 SELECTING AN AUDIO TONE	5-8
5.3.5 SELECTING AN INCUBATOR NUMBER	5-10
5.3.6 RESTORING FACTORY DEFAULT SETTINGS	5-12
5.3.7 CONFIGURING THE CONTROLLER TO NO EXTERNAL INTERFACE	5-14
5.3.8 CONFIGURING THE CONTROLLER TO A REMOTE MONITOR	5-16
5.3.9 CONFIGURING THE CONTROLLER TO A THERMAL PRINTER	5-18
5.3.10 CONFIGURING THE CONTROLLER TO A DOT MATRIX PRINTER	5-20
5.3.11 DISABLING THE BABY MODE FUNCTION (C550 CONTROLLERS ONLY)	5-22
5.3.12 SELECTING A CONTROLLER MESSAGE CENTER LANGUAGE	5-24
5.4 C500/C550 CONTROLLER SYSTEM INFORMATION MENU	5-26
5.4.1 SELECTING THE SYSTEM INFORMATION MENU	5-26
5.4.2 ACCESSING THE CONTROLLER SOFTWARE VERSION NUMBER	5-27
5.4.3 ACCESSING THE CONTROLLER SHOW CONFIGURATION MENU	5-29
5.4.4 ACCESSING THE CONTROLLER PRINT CONFIGURATION MENU	5-31
5.4.5 ACCESSING THE CONTROLLER SHOW DIAGNOSTIC LOG MENU	5-33
5.4.6 ACCESSING THE CONTROLLER PRINT DIAGNOSTIC LOG MENU	5-35

Change 2

TABLE OF CONTENTS (continued)

SECTION	PAGE
5.4.7 ACCESSING THE CONTROLLER CLEAR DIAGNOSTIC LOG MENU	5-37
5.4.8 ACCESSING THE CONTROLLER MEMORY AVAILABLE MENU	5-39
5.5 TEST AND CALIBRATION	5-41
5.5.1 GENERAL	5-41
5.5.2 TEST EQUIPMENT REQUIRED	5-41
5.5.3 TEST SYSTEM MENU	5-41
5.5.4 FAN SPEED AND AC LINE MONITORING CALIBRATION	5-54
FAN SPEED CALIBRATION (REFER TO FIGURE 5. 2 FOR ADJUSTMENT LOCATION) ..	5-54
AC LINE MONITORING CALIBRATION (REFER TO FIGURE 5. 2 FOR TEST POINT AND ADJUSTMENT LOCATIONS)	5-54
TEST SET-UP	5-54
PROCEDURE	5-54
5.5.5 LEAKAGE CURRENT TESTS	5-56
TEST SET-UP	5-56
PROCEDURE	5-56
5.5.6 OXYGEN CONCENTRATION TESTS	5-56
TEST SET-UP	5-56
PROCEDURE	5-56
5.6 TROUBLESHOOTING	5-57
5.7 REMOVAL AND REPLACEMENT PROCEDURES	5-60
5.7.1 GENERAL	5-60
5.7.2 CONTROLLER FRONT PANEL AND CONTROLLER PRINTED CIRCUIT BOARDS	5-60
CONTROLLER FRONT PANEL	5-60
DISPLAY BOARD	5-60
MAIN PRINTED CIRCUIT BOARD	5-60
IMPELLER FAN MOTOR AND AIR FLOW PROBE	5-60
AC ENTRY BOARD AND CHASSIS RIGHT SIDE PANEL	5-60
AIR TEMPERATURE PROBE	5-61
HEATER BOARD	5-61
HEATER	5-61
POWER SUPPLY	5-61
5.7.3 PNEUMATIC FRONT PANEL	5-61
5.7.4 OXYGEN INPUT VALVE FILTER CARTRIDGE	5-62
5.7.5 VHA STAND	5-62
VHA STAND ACTUATOR	5-62
UP/DOWN SWITCH	5-65
PHASE SHIFT CAPACITOR	5-65
5.7.6 REASSEMBLY OF INNER COLUMN INTO OUTER COLUMN (REFER TO FIGURE 5.6)	5-65
SECTION 6	
PARTS LIST	6-1
6.1 GENERAL	6-1
6.2 RECOMMENDED SPARE PARTS – QUANTITY OF 1 TO 5 UNITS	6-3A
SECTION 7	
DIAGRAMS	7-1
7.1 GENERAL	7-1

LIST OF TABLES

TABLE		PAGE
TABLE 1.1	SERIES CHANGE – CONTROLLER MODEL C500C–1 AND 1E	1–4
TABLE 1.2	SERIES CHANGE – CONTROLLER MODEL C550C–1 AND 1E	1–4
TABLE 1.3	SERIES CHANGE – CONTROLLER MODEL C500 XLC–1 AND 1E	1–4
TABLE 1.4	SERIES CHANGE – CONTROLLER MODEL C550 XLC–1 AND 1E	1–4
TABLE 1.5	SERIES CHANGE – HOOD/SHELL ASSEMBLY C500H–1 AND 1E 4 ACCESS DOORS, 2 IRIS PORTS, PNEUMATIC TILT	1–5
TABLE 1.6	SERIES CHANGE – HOOD/SHELL ASSEMBLY C500H–1 AND 1E 5 ACCESS DOORS, 1 IRIS PORT, PNEUMATIC TILT	1–5
TABLE 1.7	SERIES CHANGE – HOOD/SHELL ASSEMBLY C550H–1 AND 1E 4 ACCESS DOORS, 2 IRIS PORTS, PNEUMATIC TILT	1–5
TABLE 1.8	SERIES CHANGE – HOOD/SHELL ASSEMBLY C550H–1 AND 1E 5 ACCESS DOORS, 1 IRIS PORT, PNEUMATIC TILT	1–5
TABLE 1.9	SERIES CHANGE – HOOD/SHELL ASSEMBLY C500H–2 AND 2E 4 ACCESS DOORS, 2 IRIS PORTS, MANUAL TILT	1–6
TABLE 1.10	SERIES CHANGE – HOOD/SHELL ASSEMBLY C500H–2 AND 2E 5 ACCESS DOORS, 1 IRIS PORT, MANUAL TILT	1–6
TABLE 1.11	SERIES CHANGE – HOOD/SHELL ASSEMBLY C550H–2 AND 2E 4 ACCESS DOORS, 2 IRIS PORTS, MANUAL TILT	1–6
TABLE 1.12	SERIES CHANGE – HOOD/SHELL ASSEMBLY C550H–2 AND 2E 5 ACCESS DOORS, 1 IRIS PORT, MANUAL TILT	1–6
TABLE 1.13	SERIES CHANGE – HOOD/SHELL ASSEMBLY C500XLH–1 AND 1E 4 ACCESS DOORS, 2 IRIS PORTS, PNEUMATIC TILT	1–7
TABLE 1.14	SERIES CHANGE – HOOD/SHELL ASSEMBLY C500XLH–1 AND 1E 5 ACCESS DOORS, 1 IRIS PORT, PNEUMATIC TILT	1–7
TABLE 1.15	SERIES CHANGE – HOOD/SHELL ASSEMBLY C550XLH–1 AND 1E 4 ACCESS DOORS, 2 IRIS PORTS, PNEUMATIC TILT	1–7
TABLE 1.16	SERIES CHANGE – HOOD/SHELL ASSEMBLY C550XLH–1 AND 1E 5 ACCESS DOORS, 1 IRIS PORT, PNEUMATIC TILT	1–7
TABLE 1.17	SERIES CHANGE – HOOD/SHELL ASSEMBLY C500XLH–2 AND 2E 4 ACCESS DOORS, 2 IRIS PORTS, MANUAL TILT	1–8
TABLE 1.18	SERIES CHANGE – HOOD/SHELL ASSEMBLY C500XLH–2 AND 2E 5 ACCESS DOORS, 1 IRIS PORT, MANUAL TILT	1–8
TABLE 1.19	SERIES CHANGE – HOOD/SHELL ASSEMBLY C550XLH–2 AND 2E 4 ACCESS DOORS, 2 IRIS PORTS, MANUAL TILT	1–8
TABLE 1.20	SERIES CHANGE – HOOD/SHELL ASSEMBLY C550XLH–2 AND 2E 5 ACCESS DOORS, 1 IRIS PORT, MANUAL TILT	1–8
TABLE 1.21	SERIES CHANGE – VHA STAND, MODELS VHS68–1, 1E, 2 AND 2E	1–8
TABLE 3.1	SPECIFICATIONS	3–1
TABLE 5.1	DIAGNOSTIC LOG MESSAGES AND CORRECTIVE ACTIONS	5–57

LIST OF TABLES (continued)

TABLE		PAGE
TABLE 6.1	HOOD ASSEMBLY, PARTS LIST	6-5
TABLE 6.2	ACCESS PANEL ASSEMBLY, UNITS EQUIPPED WITH PNEUMATIC TILT, PARTS LIST	6-7
TABLE 6.3	ACCESS PANEL ASSEMBLY, UNITS EQUIPPED WITH MANUAL TILT, PARTS LIST	6-9
TABLE 6.4	SHELL AND PNEUMATIC TILT DECK ASSEMBLY, PARTS LIST	6-11
TABLE 6.5	SHELL AND MANUAL TILT DECK ASSEMBLY, PARTS LIST	6-17
TABLE 6.6	MANUAL TILT DECK ASSEMBLY, PARTS LIST	6-21
TABLE 6.7	CONTROLLER ASSEMBLY, PARTS LIST	6-25
TABLE 6.8	PNEUMATIC PANEL ASSEMBLY, PARTS LIST	6-29
TABLE 6.9	AC ENTRY BOARD, PARTS LIST	6-31
TABLE 6.10	HEATER BOARD, PARTS LIST	6-33
TABLE 6.11	MAIN BOARD, PARTS LIST	6-37
TABLE 6.12	DISPLAY BOARD, PARTS LIST	6-39
TABLE 6.13	CABINET STAND ASSEMBLY, PARTS LIST	6-41
TABLE 6.14	VHA STAND ASSEMBLY, PARTS LIST	6-45
TABLE 6.15	INNER COLUMN ASSEMBLY, PARTS LIST	6-49
TABLE 6.16	CABINET, VHA STAND, PARTS LIST	6-51
TABLE 6.17	I.V. POLE ASSEMBLY, VHA STAND ASSEMBLY, PARTS LISTS	6-53
TABLE 6.18	I.V. POLE ASSEMBLY, STANDARD CABINET STAND ASSEMBLY, PARTS LIST ...	6-55
TABLE 6.19	HOOD ASSEMBLY, C500/550 QT® MODEL XL, PARTS LIST	6-57
TABLE 6.20	ACCESS PANEL ASSEMBLY, C500/550 QT® MODEL XL, PARTS LIST	6-61
TABLE 6.21	SHELL AND PNEUMATIC TILT DECK ASSEMBLY, C500/550 QT® MODEL XL, PARTS LIST	6-63
TABLE 6.22	SHELL AND MANUAL TILT DECK ASSEMBLY, C500/550 QT MODEL XL, PARTS LIST	6-69
TABLE 6.23	CONTROLLER ASSEMBLY, C500/550 QT® MODEL XL, PARTS LIST	6-75

Change 4

LIST OF ILLUSTRATIONS

FIGURE	PAGE
FIGURE 1.1 ACCESSORIES	1-3
FIGURE 2.1 ASSEMBLY, INCUBATOR MOUNTED ON A STANDARD CABINET STAND	2-2
FIGURE 2.2 ASSEMBLY, INCUBATOR MOUNTED ON A VHA CABINET STAND	2-4
FIGURE 2.3 ELEVATE THE MATTRESS TILT MECHANISM	2-5
FIGURE 2.4 INSERT THE BELLOWS TUBE THROUGH THE HOOD	2-5
FIGURE 2.5 INSTALL THE BELLOWS	2-6
FIGURE 2.6 CONNECT THE BELLOWS TUBE	2-6
FIGURE 2.7 MATTRESS REMOVED FROM THE INCUBATOR	2-7
FIGURE 2.8 WEIGHING PLATFORM INSTALLED IN MATTRESS TRAY	2-7
FIGURE 2.9 MATTRESS TRAY AND MATTRESS ON WEIGHING PLATFORM	2-8
FIGURE 3.1 AIR/O ₂ CIRCULATION SYSTEM, C500/550 QT®	3-21
FIGURE 3.1A AIR/O ₂ CIRCULATION SYSTEM, C500/550 QT® XL	3-21A
FIGURE 3.2 FUNCTIONAL BLOCK DIAGRAM	3-22
FIGURE 3.3 TEMPERATURE TOO HIGH AND TOO LOW ALARMS – AUDIBLE ALARM DELAY TIME VERSUS CHANGE FROM CURRENT INCUBATOR TEMPERATURE	3-26
FIGURE 4.1 REMOVAL OF CONTROLLER	4-2
FIGURE 4.2 REMOVAL OF OPTIONAL INNER WALL	4-3
FIGURE 4.3 ACCESS PANEL OPTIONAL INNER WALL REMOVAL	4-4
FIGURE 4.4 REMOVAL OF BELLOWS TUBE FROM COLLAR	4-5
FIGURE 4.5 REMOVAL OF MAIN DECK	4-5
FIGURE 4.6 REMOVAL OF AIR INTAKE TUBE	4-6
FIGURE 4.7 REMOVAL OF HUMIDITY FILL PIPE ASSEMBLY	4-7
FIGURE 4.8 INSTALLATION OF MAIN DECK HOOD SEAT GASKET	4-9
FIGURE 4.9 INSTALLATION OF IRIS ENTRY PORT SLEEVE	4-10
FIGURE 4.10 INSTALLATION OF ACCESS DOOR GASKET	4-11
FIGURE 5.1 DIAGNOSTIC MENU STRUCTURE	5-2
FIGURE 5.2 LOCATION OF HEATER BOARD FAN SPEED AND TEMPERATURE CALIBRATION POTENTIOMETERS	5-55
FIGURE 5.3 OXYGEN INPUT VALVE ASSEMBLY	5-62
FIGURE 5.4 VHA STAND WIRING DIAGRAM-120V UNITS	5-63
FIGURE 5.5 VHA STAND WIRING DIAGRAM-220/240V UNITS	5-64
FIGURE 5.6 INSERTION OF GIB PINS	5-66
FIGURE 6.1 PARTS LOCATION DIAGRAM, HOOD ASSEMBLY	6-4
FIGURE 6.2 PARTS LOCATION DIAGRAM, ACCESS PANEL ASSEMBLY UNITS EQUIPPED WITH PNEUMATIC TILT	6-6
FIGURE 6.3 PARTS LOCATION DIAGRAM, ACCESS PANEL ASSEMBLY UNITS EQUIPPED WITH MANUAL TILT	6-8

Change 5

LIST OF ILLUSTRATIONS (continued)

FIGURE	PAGE
FIGURE 6.4 PARTS LOCATION DIAGRAM, SHELL AND PNEUMATIC TILT DECK ASSEMBLY ...	6-10
FIGURE 6.5 PARTS LOCATION DIAGRAM, SHELL AND MANUAL TILT DECK ASSEMBLY	6-16
FIGURE 6.6 PARTS LOCATION DIAGRAM, MANUAL TILT DECK ASSEMBLY	6-20
FIGURE 6.7 PARTS LOCATION DIAGRAM, CONTROLLER ASSEMBLY (SHEET 1 OF 3)	6-22
FIGURE 6.7 PARTS LOCATION DIAGRAM, CONTROLLER ASSEMBLY (SHEET 2 OF 3)	6-23
FIGURE 6.7 PARTS LOCATION DIAGRAM, CONTROLLER ASSEMBLY (SHEET 3 OF 3)	6-24
FIGURE 6.8 PARTS LOCATION DIAGRAM, PNEUMATIC PANEL ASSEMBLY	6-28
FIGURE 6.9 PARTS LOCATION DIAGRAM, AC ENTRY BOARD	6-30
FIGURE 6.10 PARTS LOCATION DIAGRAM, HEATER BOARD	6-32
FIGURE 6.11 PARTS LOCATION DIAGRAM, MAIN BOARD	6-36
FIGURE 6.12 PARTS LOCATION DIAGRAM, DISPLAY BOARD	6-38
FIGURE 6.13 PARTS LOCATION DIAGRAM, CABINET STAND ASSEMBLY	6-40
FIGURE 6.14 PARTS LOCATION DIAGRAM, VHA STAND ASSEMBLY (SHEET 1 OF 2)	6-43
FIGURE 6.14 PARTS LOCATION DIAGRAM, VHA STAND ASSEMBLY (SHEET 2 OF 2)	6-44
FIGURE 6.15 PARTS LOCATION DIAGRAM, INNER COLUMN ASSEMBLY	6-48
FIGURE 6.16 PARTS LOCATION DIAGRAM, CABINET, VHA STAND	6-50
FIGURE 6.17 PARTS LOCATION DIAGRAM, I.V. POLE ASSEMBLY, VHA STAND	6-52
FIGURE 6.18 PARTS LOCATION DIAGRAM, I.V. POLE ASSEMBLY, STANDARD CABINET STAND	6-54
FIGURE 6.19 PARTS LOCATION DIAGRAM, HOOD ASSEMBLY, C500/550 QT® MODEL XL	6-56
FIGURE 6.20 PARTS LOCATION DIAGRAM, ACCESS PANEL ASSEMBLY, C500/550 QT® MODEL XL	6-60
FIGURE 6.21 PARTS LOCATION DIAGRAM, SHELL AND PNEUMATIC TILT DECK ASSEMBLY, C500/550 QT® MODEL XL	6-62
FIGURE 6.22 PARTS LOCATION DIAGRAM, SHELL AND MANUAL TILT DECK ASSEMBLY, C500/550 QT MODEL XL	6-68
FIGURE 6.23 PARTS LOCATION DIAGRAM, CONTROLLER ASSEMBLY, C500/550 QT® MODEL XL	6-72
FIGURE 7.1 PNEUMATIC SCHEMATIC	7-2
FIGURE 7.2 INTERCONNECTION DIAGRAM	7-3
FIGURE 7.3 SCHEMATIC DIAGRAM, AC ENTRY BOARD	7-4
FIGURE 7.3A SCHEMATIC DIAGRAM, AC ENTRY BOARD, 230V, GERMAN	7-4A
FIGURE 7.4 SCHEMATIC DIAGRAM, HEATER BOARD	7-5
FIGURE 7.5 SCHEMATIC DIAGRAM, MAIN BOARD (SHEET 1 OF 2)	7-6
FIGURE 7.5 SCHEMATIC DIAGRAM, MAIN BOARD (SHEET 2 OF 2)	7-7
FIGURE 7.6 SCHEMATIC DIAGRAM, DISPLAY BOARD	7-8
FIGURE 7.7 SCHEMATIC DIAGRAM, MONITOR HYBRID	7-9
FIGURE 7.8 SCHEMATIC DIAGRAM, CONTROL HYBRID	7-10

TABLE OF DEFINITIONS AND SYMBOLS

TECHNICAL DEFINITIONS

Control Zone. A plane 10 cm (4 in) above the mattress with an area defined by the center of four quadrants formed by lines that divide the width and length of the mattress surface.

Incubator Temperature. Air temperature at a point 10 cm (4 in) above and centered over the mattress surface

Steady Temperature Condition. The condition reached when the average **Incubator Temperature** does not vary more than 0.2 °C over a period of one hour.

Temperature Overshoot. The amount by which **Incubator Temperature** exceeds average **Incubator Temperature** during **Steady Temperature Condition**, resulting from a change in temperature.

Temperature Rise Time. The time required for the **Incubator Temperature** to rise 10 °C.

Temperature Uniformity. The amount by which the average temperature at each of four points 10 cm (4 in.) above the mattress surface differs from the average **Incubator Temperature** at **Steady Temperature Condition**. The four points are the centers of four quadrants formed by lines that divide the width and length of the mattress surface.

Temperature Variation. The difference between the **Incubator Temperature** and the **Average Incubator Temperature** during **Steady Temperature Condition**.

NOTE, IMPORTANT, CAUTION, AND WARNING

NOTE: A Note is inserted in text to point out procedures or conditions which may otherwise be misinterpreted or overlooked. A Note may also be used to clarify apparently contradictory or confusing situations.

IMPORTANT: Similar to a Note but used where greater emphasis is required.

CAUTION: A Caution is inserted in text to call attention to a procedure which, if not followed exactly, can lead to damage or destruction of the equipment or improper operation.

WARNING: A Warning is inserted in text to call attention to dangerous or hazardous conditions inherent to the operation, cleaning, and maintenance of the equipment which may result in personal injury or death of the operator or patient.

Change 4

SYMBOLS



Attention; consult accompanying documents.



Type B equipment with an F type floating applied part.



Caution: Electric shock hazard. Refer service to qualified personnel.



AC power.



Protective earth (ground).



PRESS TO STOP/START TIMER



PRESS TO RESET/TURN OFF TIMER



**LIGHTS TO INDICATE UNIT IS OPERATING
IN BABY MODE**



PRESS TO ENTER BABY



**LIGHTS TO INDICATE UNIT IS OPERATING IN
AIR MODE**



PRESS TO ENTER AIR MODE



**LIGHTS TO INDICATE TEMPERATURE
OVERRIDE MODE**



**PRESS TO ENTER TEMPERATURE
OVERRIDE MODE**



PRESS TO ENTER SET TEMPERATURE



PRESS TO RAISE SET TEMPERATURE



PRESS TO SELECT CELSIUS OR FAHRENHEIT

Change 4



PRESS TO SILENCE/RESET AUDIBLE ALARMS



LIGHTS TO INDICATE KEYPAD IS LOCKED



PRESS TO LOCK OR UNLOCK THE KEYPAD



PRESS TO TURN POWER ON OR OFF

Change 4

SECTION 1 GENERAL INFORMATION

1.1 INTRODUCTION

This manual provides instructions for installation, maintenance and repair of the Isolette® Infant Incubators, Models C500 QT® and C550 QT® and C500 QT® and C550 QT® Model XL.

This manual is intended for use only by trained, qualified service personnel. Instructions for the operator of the equipment are provided in a separate operator's manual.

1.2 DESCRIPTION

1.2.1 ISOLETTE® INFANT INCUBATOR, MODEL C500

The Isolette® Infant Incubator, Model C500, provides air temperature control from 20 to 37 °C (37 to 39 °C in Temperature Override Mode) as selected by the **Air Set Temperature** Up/Down Arrow keys on the front panel.

1.2.2 ISOLETTE® INFANT INCUBATOR, MODEL C550

The Isolette® Infant Incubator, Model C550, provides air temperature control from 20 to 37 °C (37 to 39 °C in Temperature Override Mode) as selected by the **Air Set Temperature** Up/Down Arrow keys on the front panel.

In addition, it provides a sensing probe which can be attached directly to the infant's skin. Using this probe, the infant's temperature can be controlled from 34 to 37 °C (37 to 38 °C in Temperature Override Mode) as selected by the **Baby Set Temperature** Up/Down Arrow keys on the front panel.

1.3 ACCESSORIES

Accessories available for the C500/C550 QT® are listed below and illustrated in Figure 1.1. Refer to Section 6, Part Numbers, Additional Accessories, a list of operator-replaceable parts and single use items.

- Cabinet Stand
- Guard Rail
- Rail System for Standard Cabinet Stand
- SOLAIR™ Transparent Hood Warmer
- MICRO-LITE™ Phototherapy System
- DEW-ETTE® Incubator Humidifier (Not Shown)
- WARM WEIGH® Infant Scale, Model I20
- Remote Alarm Module
- VHA (Vertical Height Adjustable) Stand
- Rail System for VHA Stand
- Monitor Shelf Package
- Inner Walls (refer to Figure 4.2)
- ATHENA® Shelf Assembly

Change 4

**C500/C550
GENERAL INFORMATION**

- ATHENA® PAM Mounting Kit
- Utility Pole Assembly
- IV Tree Assembly
- Ventilator Mounting Pole
- Oxygen Flowmeter Kit
- Air Flow Kit
- Suction Kit
- Blender Kit
- MICRO-LITE™ Pivot Arm Assembly

Change 4

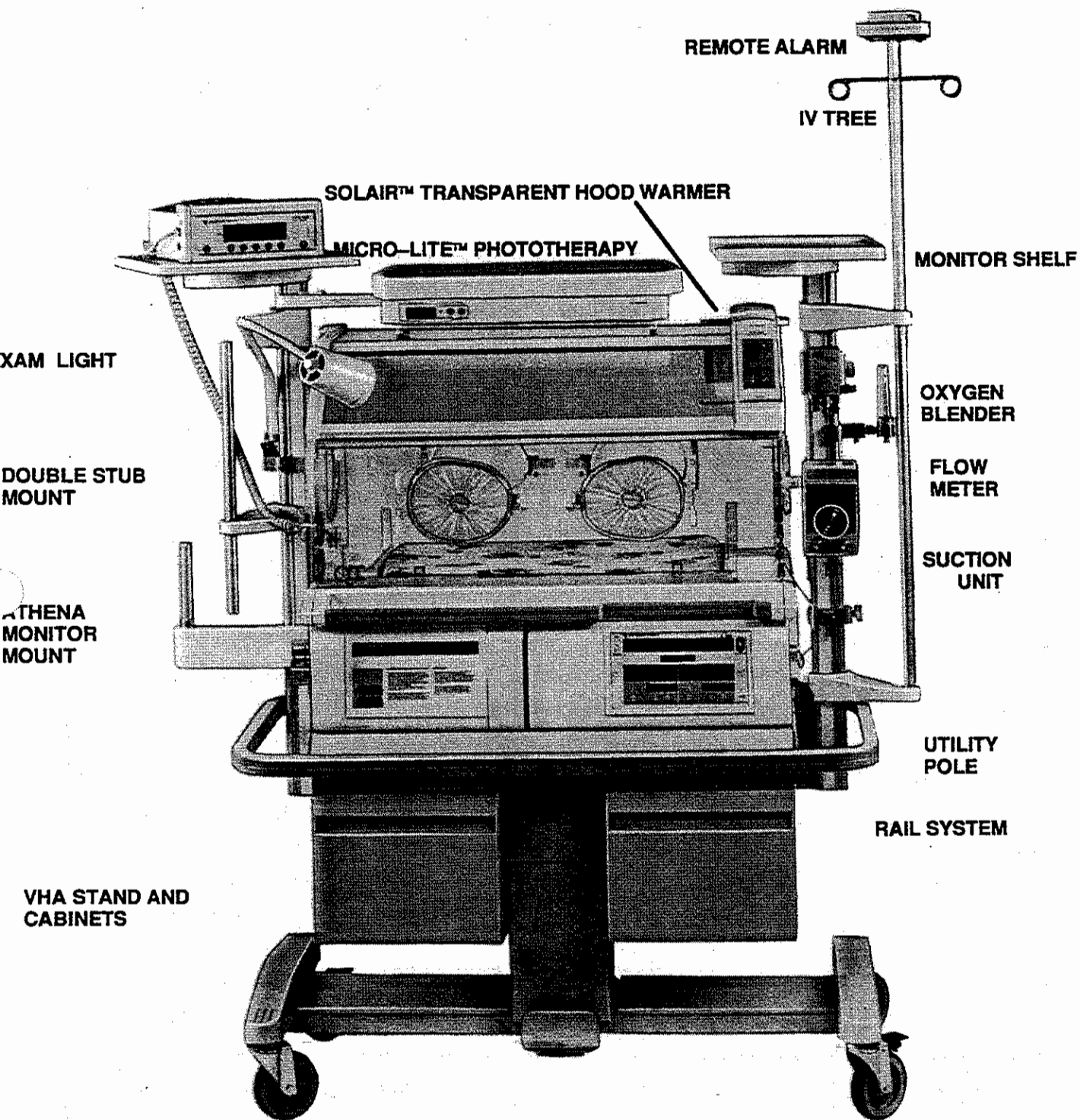

FIGURE 1.1 ACCESSORIES

1.4 MODEL IDENTIFICATION SERIES CHANGE

The Isolette® Infant Incubators, Models C500 QT® and C550 QT®, have two Data Tags which list model identification and series number. The locations of the data tags are as follows:

1. CONTROLLER: Located on the inside top panel.
2. HOOD/ SHELL ASSEMBLY: Located on the right side panel of the Shell.

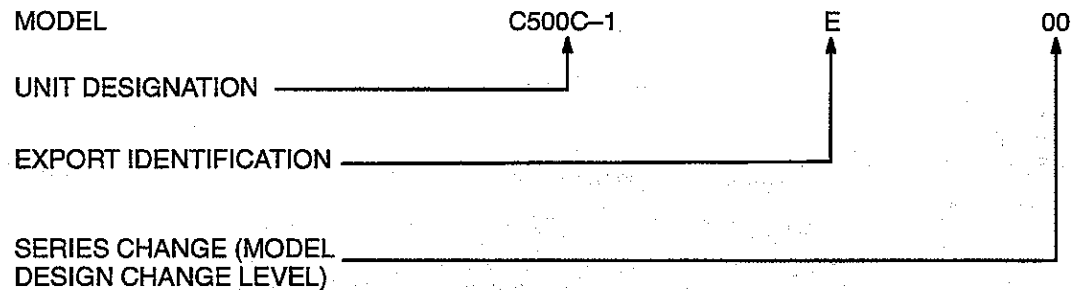

TABLE 1.1 SERIES CHANGE – CONTROLLER MODEL C500C-1 AND 1E

SERIES NO.	DESCRIPTION	ITEMS/ASSEMBLIES AFFECTED
00	Original Design	None

TABLE 1.2 SERIES CHANGE – CONTROLLER MODEL C550C-1 AND 1E

SERIES NO.	DESCRIPTION	ITEMS/ASSEMBLIES AFFECTED
00	Original Design	None

TABLE 1.3 SERIES CHANGE – CONTROLLER MODEL C500XLC-1 AND 1E

SERIES NO.	DESCRIPTION	ITEMS/ASSEMBLIES AFFECTED
00	Original Design	None

TABLE 1.4 SERIES CHANGE – CONTROLLER MODEL C550XLC-1 AND 1E

SERIES NO.	DESCRIPTION	ITEMS/ASSEMBLIES AFFECTED
00	Original Design	None

**TABLE 1.5 SERIES CHANGE – HOOD/SHELL ASSEMBLY C500H–1 AND 1E
4 ACCESS DOORS, 2 IRIS PORTS, PNEUMATIC TILT**

SERIES NO.	DESCRIPTION	ITEMS/ASSEMBLIES AFFECTED
00	Original Design	None
02	Redesign Mattress Stops on Hood and Access Panel	68 505 72 and 68 506 71

**TABLE 1.6 SERIES CHANGE – HOOD/SHELL ASSEMBLY C500H–1 AND 1E
5 ACCESS DOORS, 1 IRIS PORT, PNEUMATIC TILT**

SERIES NO.	DESCRIPTION	ITEMS/ASSEMBLIES AFFECTED
00	Original Design	None
03	Redesign Mattress Stops on Hood and Access Panel	68 505 71 and 68 506 71

**TABLE 1.7 SERIES CHANGE – HOOD/SHELL ASSEMBLY C550H–1 AND 1E
4 ACCESS DOORS, 2 IRIS PORTS, PNEUMATIC TILT**

SERIES NO.	DESCRIPTION	ITEMS/ASSEMBLIES AFFECTED
01	Original Design	None
02	Redesign Mattress Stops on Hood and Access Panel	68 505 72 and 68 506 71

**TABLE 1.8 SERIES CHANGE – HOOD/SHELL ASSEMBLY C550H–1 AND 1E
5 ACCESS DOORS, 1 IRIS PORT, PNEUMATIC TILT**

SERIES NO.	DESCRIPTION	ITEMS/ASSEMBLIES AFFECTED
00	Original Design	None
03	Redesign Mattress Stops on Hood and Access Panel	68 505 71 and 68 506 71

Change 4

**TABLE 1.9 SERIES CHANGE – HOOD/SHELL ASSEMBLY C500H-2 AND 2E
4 ACCESS DOORS, 2 IRIS PORTS, MANUAL TILT**

SERIES NO.	DESCRIPTION	ITEMS/ASSEMBLIES AFFECTED
00	Original Design	None
02	Redesign Mattress Stops on Hood and Access Panel	68 505 72 and 68 506 80

**TABLE 1.10 SERIES CHANGE – HOOD/SHELL ASSEMBLY C500H-2 AND 2E
5 ACCESS DOORS, 1 IRIS PORT, MANUAL TILT**

SERIES NO.	DESCRIPTION	ITEMS/ASSEMBLIES AFFECTED
00	Original Design	None
03	Redesign Mattress Stops on Hood and Access Panel	68 505 71 and 68 506 80

**TABLE 1.11 SERIES CHANGE – HOOD/SHELL ASSEMBLY C550H-2 AND 2E
4 ACCESS DOORS, 2 IRIS PORTS, MANUAL TILT**

SERIES NO.	DESCRIPTION	ITEMS/ASSEMBLIES AFFECTED
00	Original Design	None
02	Redesign Mattress Stops on Hood and Access Panel	68 505 72 and 68 506 80

**TABLE 1.12 SERIES CHANGE – HOOD/SHELL ASSEMBLY C550H-2 AND 2E
5 ACCESS DOORS, 1 IRIS PORT, MANUAL TILT**

SERIES NO.	DESCRIPTION	ITEMS/ASSEMBLIES AFFECTED
00	Original Design	None
03	Redesign Mattress Stops on Hood and Access Panel	68 505 71 and 68 506 80

Change 4

**TABLE 1.13 SERIES CHANGE – HOOD/SHELL ASSEMBLY C500XLH-1 AND 1E
4 ACCESS DOORS, 2 IRIS PORTS, PNEUMATIC TILT**

SERIES NO.	DESCRIPTION	ITEMS/ASSEMBLIES AFFECTED
00	Original Design	None

**TABLE 1.14 SERIES CHANGE – HOOD/SHELL ASSEMBLY C500XLH-1 AND 1E
5 ACCESS DOORS, 1 IRIS PORT, PNEUMATIC TILT**

SERIES NO.	DESCRIPTION	ITEMS/ASSEMBLIES AFFECTED
01	Original Design	None

**TABLE 1.15 SERIES CHANGE – HOOD/SHELL ASSEMBLY C550XLH-1 AND 1E
4 ACCESS DOORS, 2 IRIS PORTS, PNEUMATIC TILT**

SERIES NO.	DESCRIPTION	ITEMS/ASSEMBLIES AFFECTED
00	Original Design	None

**TABLE 1.16 SERIES CHANGE – HOOD/SHELL ASSEMBLY C550XLH-1 AND 1E
5 ACCESS DOORS, 1 IRIS PORT, PNEUMATIC TILT**

SERIES NO.	DESCRIPTION	ITEMS/ASSEMBLIES AFFECTED
01	Original Design	None

Change 4

**TABLE 1.17 SERIES CHANGE – HOOD/SHELL ASSEMBLY C500XLH-2 AND 2E
4 ACCESS DOORS, 2 IRIS PORTS, MANUAL TILT**

SERIES NO.	DESCRIPTION	ITEMS/ASSEMBLIES AFFECTED
00	Original Design	None

**TABLE 1.18 SERIES CHANGE – HOOD/SHELL ASSEMBLY C500XLH-2 AND 2E
5 ACCESS DOORS, 1 IRIS PORT, MANUAL TILT**

SERIES NO.	DESCRIPTION	ITEMS/ASSEMBLIES AFFECTED
01	Original Design	None

**TABLE 1.19 SERIES CHANGE – HOOD/SHELL ASSEMBLY C550XLH-2 AND 2E
4 ACCESS DOORS, 2 IRIS PORTS, MANUAL TILT**

SERIES NO.	DESCRIPTION	ITEMS/ASSEMBLIES AFFECTED
00	Original Design	None

**TABLE 1.20 SERIES CHANGE – HOOD/SHELL ASSEMBLY C550XLH-2 AND 2E
5 ACCESS DOORS, 1 IRIS PORT, MANUAL TILT**

SERIES NO.	DESCRIPTION	ITEMS/ASSEMBLIES AFFECTED
01	Original Design	None

TABLE 1.21 SERIES CHANGE –VHA STAND, MODELS VHS68-1,1E, 2 AND 2E

SERIES NO.	DESCRIPTION	ITEMS/ASSEMBLIES AFFECTED
00	Original Design	None

SECTION 2 INSTALLATION

2.1 UNPACKING

Typically, the Cabinet Stand (the optional VHA Stand), the Hood/Base Assembly, Filter/Filter Cover Assembly and the Guard Rail are shipped in separate cartons. When removing the equipment from the cartons, take care not to scratch or otherwise damage unprotected surfaces. Remove all packing materials from the Shell Assembly.

2.2 ASSEMBLY—INCUBATORS EQUIPPED WITH STANDARD CABINET STAND

CAUTION: Two people are required to assemble the Hood/Base Assembly and the Cabinet Stand.

Instructions for assembling the Incubator are provided below:

- A. **REMOVE THE CONTROLLER FROM THE INCUBATOR.** Attach the Guard Rail to the underside of the Base Assembly using the 6 No. 10 x 1/2" Screws and Keps nuts supplied (see Figure 2.1). Replace the Controller.
- B. **PLACE THE GUARD RAIL AND BASE ASSEMBLY** on the Cabinet Stand as shown in Figure 2.1.

WARNING: The Incubator must be attached to the Cabinet Stand using the clamps provided. Failure to do so could result in the Incubator separating from the stand if sufficiently tilted, particularly with the hood open.

- C. **SECURE THE HOOD/BASE ASSEMBLY** to the Cabinet Stand using the clamp on each side of the Cabinet Stand. Adjust threaded clamp on the stand for positive latching. Locking bar should be approximately horizontal when clamp is engaged in retainer. Lock clamp by rotating locking bar to vertical position (see Figure 2.1).

IMPORTANT: This Incubator has been shipped without a Filter and Filter Cover Assembly. The Filter Cover Assembly has been shipped in a separate carton. **DO NOT** place Incubator into use until properly installed.

- D. **INSTALL THE AIR FILTER AND FILTER COVER** on the rear of the unit (refer to Paragraph 2.7.2, Step K). If the unit is to be equipped with a Dew-ette® Incubator Humidifier, Model DH90, refer to the Operator's Manual for the Dew-ette® Incubator Humidifier and install the Air Intake Valve Assembly, Special Air Filter and Humidifier Filter Cover.
- E. **CONNECT THE POWER CORD TO THE INCUBATOR.**

Screw, 10 – 32 x 1/2" (Qty 6)
■ Nut, Keps, 10 – 32 (Qty 6)

99 042 01
99 107 36

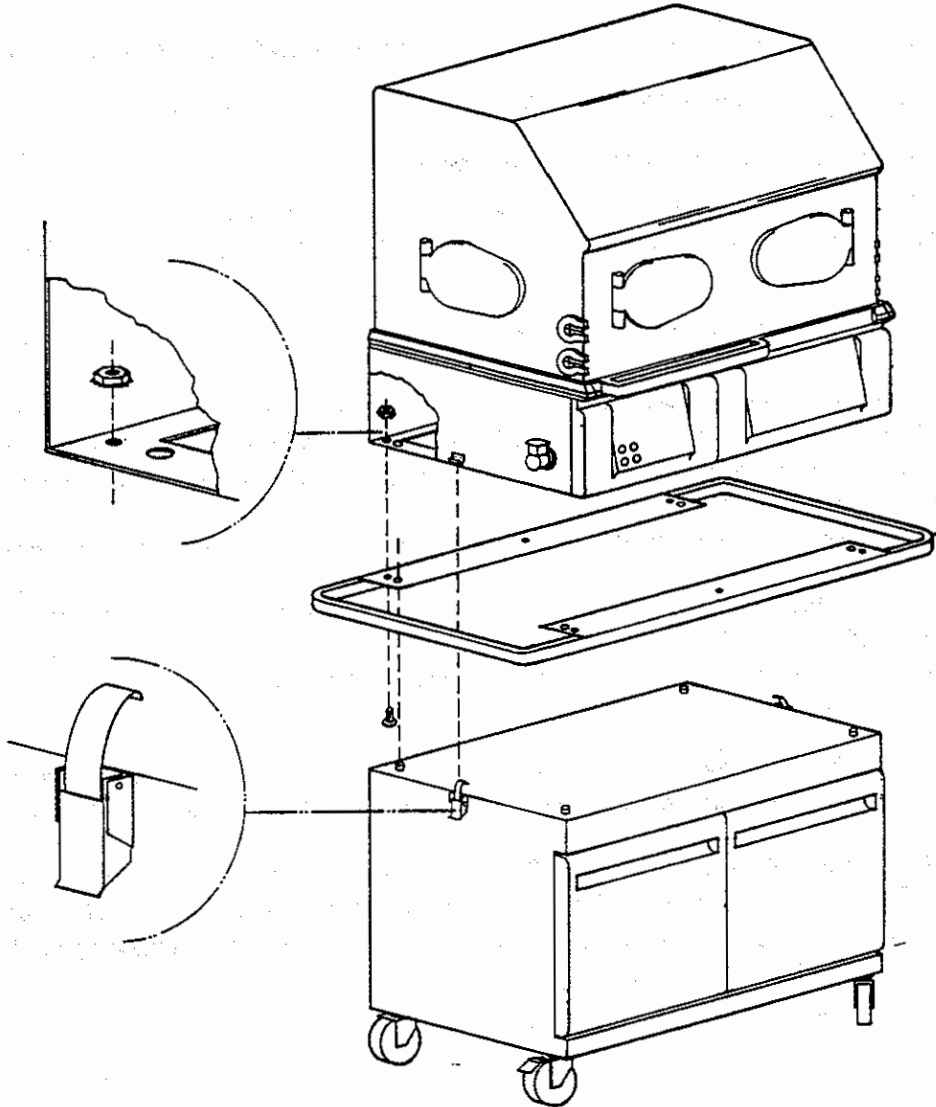

FIGURE 2.1 ASSEMBLY, INCUBATOR MOUNTED ON A STANDARD CABINET STAND

Change 5

2.3 ASSEMBLY—INCUBATORS EQUIPPED WITH OPTIONAL VERTICAL HEIGHT ADJUSTABLE STAND

CAUTION: Heavy Equipment – To prevent injury or damage to the Incubator/Stand, two persons of sufficient strength are required to adequately control the Incubator when transporting it.

CAUTION: Always lower the Incubator to its lowest position prior to transport for optimum stability.

- A. **REMOVE THE CONTROLLER FROM THE INCUBATOR.** Attach the Guard Rail to the underside of the Base Assembly using the 6 bolts and lock nuts supplied (see Figure 2.2).
- B. **PLACE THE GUARD RAIL AND BASE ASSEMBLY** on the VHA (Vertical Height Adjustable) Stand as shown in Figure 2.2.

WARNING: The Incubator must be attached securely to the VHA Stand using the clamps provided. Failure to do so could result in the Incubator separating from the stand if sufficiently tilted, particularly with the hood open.

- C. **SECURE THE BASE ASSEMBLY** to the VHA Stand using the clamp on each side of the VHA Stand.

WARNING: The VHA Stand is intended for use with ISOLETTE® Infant Incubators which use the C500/550 QT® Incubator Base Assembly. DO NOT USE the VHA Stand with other Incubators. Incubator instability or tip-over could result.

IMPORTANT: Check to be certain Incubator is firmly secured to the stand at both ends. Do not place in service if not firmly secured.

IMPORTANT: This Incubator has been shipped without a Filter and Filter Cover Assembly. Filter Cover Assembly has been shipped in a separate carton. DO NOT place Incubator into use until properly installed.

- D. **INSTALL THE AIR FILTER AND FILTER COVER** on the rear of the unit (refer to Paragraph 2.7.2, Step K). If the unit is to be equipped with a Dew-ette® Incubator Humidifier, Model DH90, refer to the Operator's Manual for the Dew-ette® Incubator Humidifier and install the Air Intake Valve Assembly, Special Air Filter and Humidifier Filter Cover.
- E. **CONNECT THE VHA POWER CORD** to the wall receptacle and the interconnecting power cord on the VHA Stand to the Incubator power cord receptacle.

Screw, 10 – 32 x 1/2" (Qty 6)
■ Nut, Keps, 10 – 32 (Qty 6)

99 042 01
99 107 36

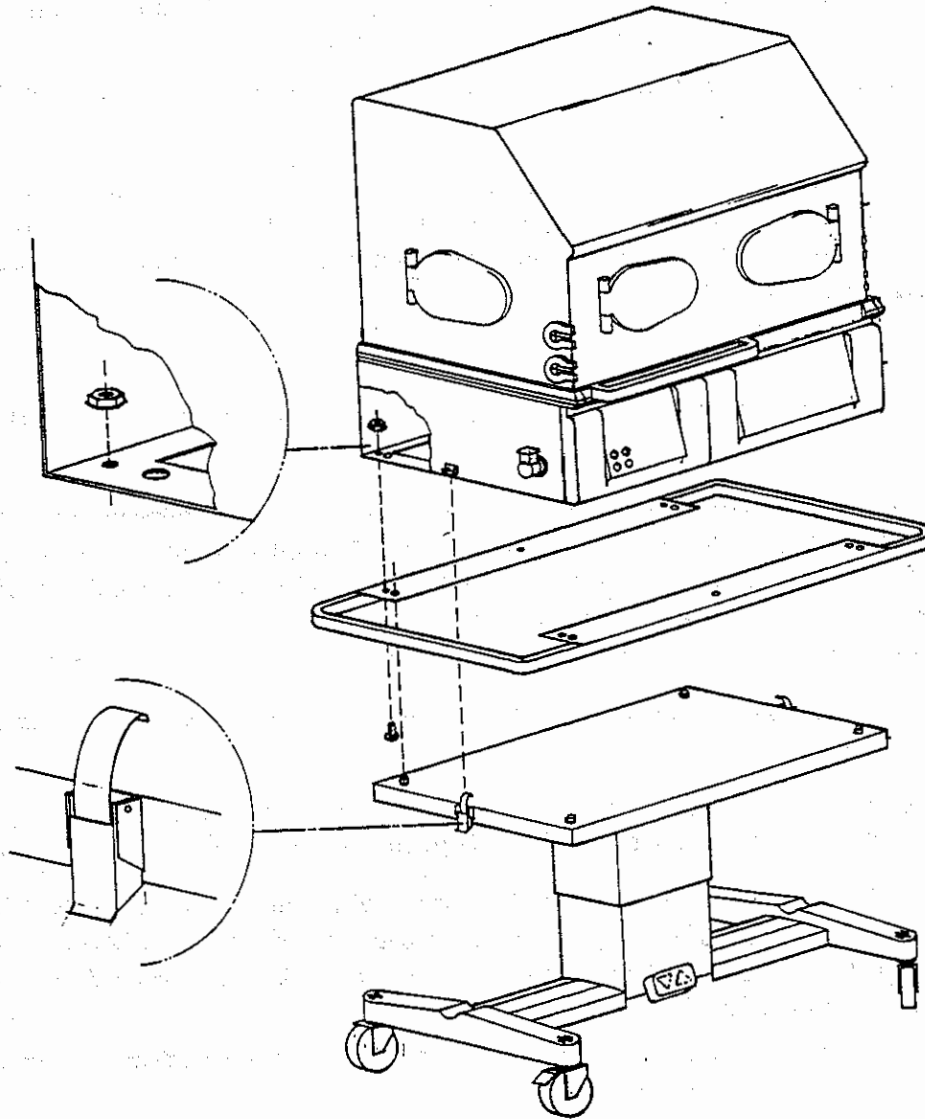

FIGURE 2.2 ASSEMBLY, INCUBATOR MOUNTED ON A VHA CABINET STAND

Change 5

2.4 INSTALLATION OF THE MATTRESS TILT BELLOWS

- A. REMOVE THE MATTRESS TRAY and elevate the left and right ends of the Mattress Tilt Mechanism (Figure 2.3).

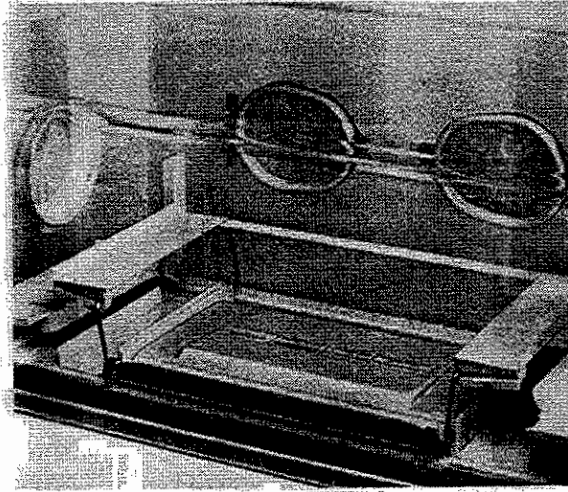

FIGURE 2.3 ELEVATE THE MATTRESS TILT MECHANISM

- B. INSERT THE BELLOWS TUBE through the hole in the rear of the Incubator Hood (Figure 2.4).

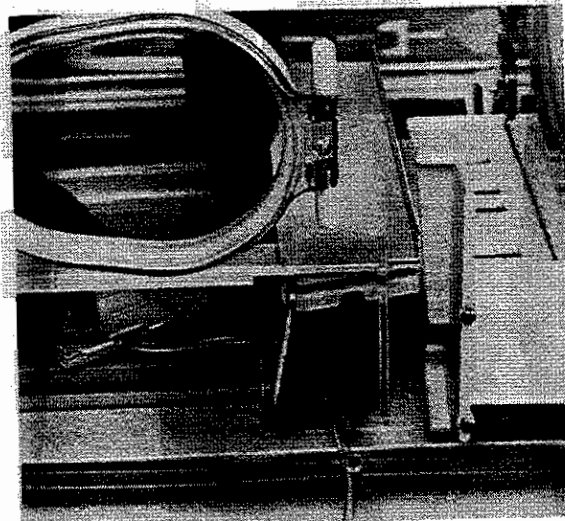

FIGURE 2.4 INSERT THE BELLOWS TUBE THROUGH THE HOOD

- C. SLIDE A BELLOWS INTO THE LEFT SIDE OF THE TILT MECHANISM (REFER TO FIGURE 2.5).

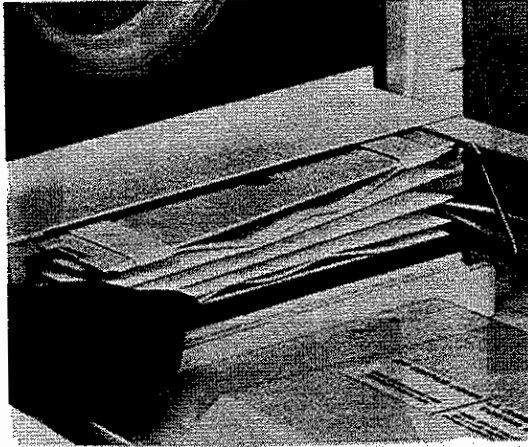

FIGURE 2.5 INSTALL THE BELLOWS

- D. CONNECT THE BELLOWS TUBE to the fitting below the hole by inserting the tube into the red collar as far as it will go (Figure 2.6).

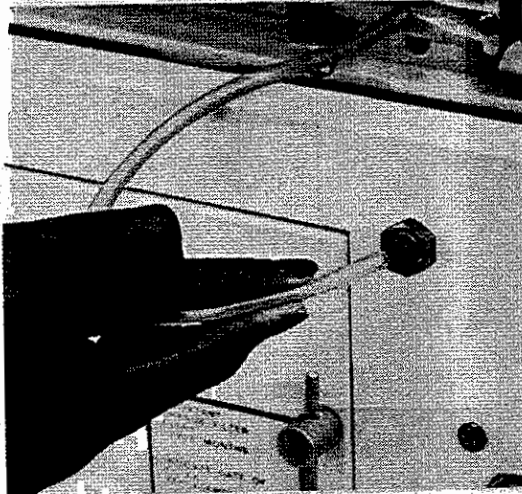

FIGURE 2.6 CONNECT THE BELLOWS TUBE

- E. REPEAT STEPS B AND C for the right side bellows.
F. CONNECT A WALL AIR SOURCE to the DISS Fitting (Figure 4.4 of the Operator's Manual).

2.5 WARM WEIGH® INFANT SCALE, MODEL I20 (ACCESSORY)

For more information, refer to the I20/W30 Operator's Manual.

IMPORTANT: The Load Cell must be unlocked before operating the scale. Refer to the I20/W30 Installation, Test and Calibration Instructions for the procedure.

A. OPEN FRONT ACCESS PANEL of the Incubator.

B. REMOVE THE MATTRESS from the Incubator (Figure 2.7).

IMPORTANT: Use the mattress provided with the scale. Use of the C500/550 QT® mattress may cause inaccurate readings due to interference with the surrounding walls.

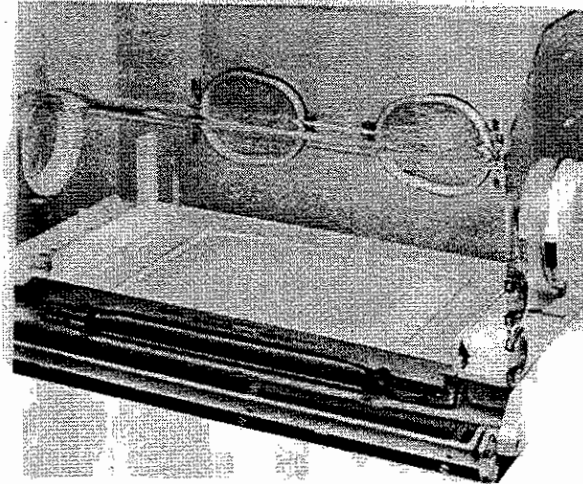

FIGURE 2.7 MATTRESS REMOVED FROM THE INCUBATOR

C. INSTALL THE WEIGHING PLATFORM in the Incubator Mattress Tray (Figure 2.8). Make sure it is level.

D. PLACE THE MATTRESS TRAY AND MATTRESS PROVIDED on the Weighing Platform (Figure 2.9).

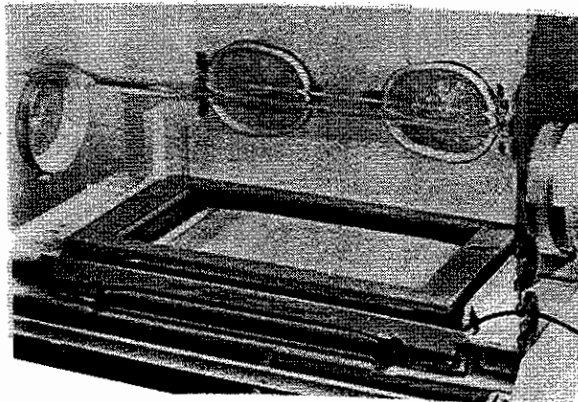

FIGURE 2.8 WEIGHING PLATFORM INSTALLED IN MATTRESS TRAY

E. INSERT THE CABLE INTO ONE OF THE HOOD ACCESS PORTS (Figure 2.8).

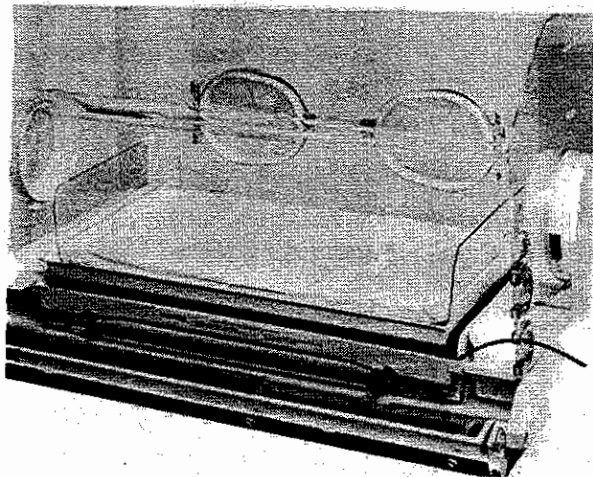

FIGURE 2.9 MATTRESS TRAY AND MATTRESS ON WEIGHING PLATFORM

2.6 CONFIGURING THE INCUBATOR

Upon installation, or at any time during use, the following Incubator parameters may be changed to meet the current needs of the operator. This is accomplished by first selecting the Configuration Menu. Refer to Paragraph 5.3.1. Then select the desired parameter.

2.6.1 PROCEDURAL SILENCE TIME

Procedural Silence Time is the length of time the alarms are silenced while the operator is performing routine procedures that may cause inadvertent alarms. The factory default setting is 15 minutes. The user may change this duration from 0 minutes up to 15 minutes in 1-minute increments. Refer to Paragraph 5.3.2 to set the Procedural Silence Time.

IMPORTANT: *Selecting a Procedural Silence Time of 0 minutes disables the Procedural Silence Time function.*

2.6.2 KEYPAD LOCK TIME DURATION

Keypad Time-to-Lock duration is the length of time the Keypad will remain unlocked after the last key depression. The factory default setting is 1 minute. The user may change this duration from 0 minutes up to 10 minutes in 1-minute increments. Refer to Paragraph 5.3.3 to set the Keypad Lock Time.

IMPORTANT: *If a time duration of 0 minutes is selected, the Keypad will not re-lock automatically; the user must press the Keypad Lock key to lock the Keypad.*

2.6.3 AUDIO TONE

There are five Incubator audio tones available. The factory default setting is Tone Number 3. During the selection process, the user is given an audible sample of each tone to aid in the selection of a tone. Refer to Paragraph 5.3.4 for Audio Tone Selection.

2.6.4 INCUBATOR NUMBER

The Incubator may be assigned a number from 01 to 99. The factory default setting is 01. This number is important when the Incubator has been connected to a remote monitor or printer via the **SERIAL PORT** located on the side panel. Refer to Paragraph 5.3.5 to select an Incubator Number.

2.6.5 RESTORING FACTORY DEFAULTS

The factory default settings are as follows:

- Air Mode.
- Air Set Temperature = 35 °C.
- Baby Set Temperature = 36.5 °C.
- Procedural Silence Time = 15 minutes.
- Keypad Lock Time Duration = 1 Minute.
- Incubator Number = 01.
- No External Interface (**SERIAL PORT** disabled).
- Audio Tone Number 3.

These may be restored by performing the procedure described in Paragraph 5.3.6.

2.6.6 NO EXTERNAL INTERFACE

The **SERIAL PORT** located on the Incubator side panel may be disabled by performing the procedure described in Paragraph 5.3.7.

NOTE: No External Interface is the factory default setting.

2.6.7 CONFIGURING FOR A REMOTE MONITOR

The **SERIAL PORT** located on the Incubator side panel may be configured to communicate with a remote monitor. When configured to a remote monitor, the controller will provide the following data:

NOTE: The protocol for the **SERIAL PORT** is provided in Section 3, Paragraph 3.4.3 Main Board, Serial Communications.

- Heater Power.
- Incubator Number (refer to Paragraph 2.6.4).
- Air and Set Point Temperature (C500 will only provide Air Set Temperature) along with any changes.
- Current Air and Baby Temperature every 6 minutes (C500 will only provide Air Temperature).
- Any Alarm Messages that occur.
- Any changes to the Configuration Menu.
- Any change from Air Mode to Baby Mode or vice versa (C550 only).

Information is sent out as a data packet containing codes corresponding to alarms, status, etc. Each data packet begins with STX and ends with an ETX. In addition to the information, a transmission check sum is included.

A typical data packet is as follows:

InnA36.0? * = STX/ETX
 ? = Check sum of previous data bytes (not including check sum or ETX)

All packets begin with a "packet identifier" such as *Inn, which is translated as follows:

- * STX
- l Denotes "Incubator number" (set by user, (refer to Paragraph 2.6.4 above)
- nn This is the actual 2-digit Incubator number set by the user (range = 0 to 99)

Following are the data packet identifier codes and their associated information which are transmitted either at synchronous or asynchronous rates. Synchronous data occur every 6 seconds and consist of a group of three packets of data: current Air Temperature, Baby Temperature and Heater Power. Asynchronous data are sent as they occur (example: an alarm is detected or a change in state, example: change from Air to Baby Mode). Synchronous data will continue to be sent unless a NEEDS SERVICE NOW message is present.

The current codes which are supported are listed below. Note that examples given are for selected Incubator number of 05.

CODE	NAME	TYPICAL PACKET	TRANSMISSION RATE
A	Air Temperature	*I05A36.0?*	Synchronous
B	Baby Temperature	*I05B34.5?*	Synchronous
C	Air Set Temperature	*I05C35.5?*	Asynchronous
D	Baby Set Temperature	*I05D36.4?*	Asynchronous
E	Heater Power	*I05E08?*	Synchronous
G	Baby Mode Activated	*I05G?*	Asynchronous
F	Air Mode Activated	*I05F?*	Asynchronous
H	Alarm Detected	*I05H3?*	Asynchronous
I	Alarm Acknowledged	*I05I?*	Asynchronous
J	Temp Override Active	*I05J?*	Asynchronous
K	Procedural Silence Activated	*I05K?*	Asynchronous
L	Procedural Silence Deactivated	*I05L?*	Asynchronous
Q	Alarm Cleared	*I05Q3?*	Asynchronous
X	Needs Service Now	*I05X?*	Asynchronous

NOTE 1: The two digit heater power number (08 in the example above) denotes the number of segments lit at 10% of full heater power per segment (range = 00 to 10).

NOTE 2: The value following the "H" or "Q" code corresponds to the following alarm messages:

- 0 – Air Temp Probe Fail
- 1 – High Temperature
- 2 – No Air Flow
- 3 – Air (or Baby) Temp Too Low (depends on current mode selected control)
- 4 – Air (or Baby) Temp Too High (depends on current mode selected control)
- 5 – Baby Temp Probe Fail

NOTE 3: After this message is sent, RS232 communications will cease until the Incubator power is recycled.

The **SERIAL PORT** may be configured to communicate with a remote monitor by performing the procedure described in Paragraph 5.3.8.

IMPORTANT: When a remote monitor is connected to the **SERIAL PORT**, verify proper data transfer/duplication prior to use.

2.6.8 CONFIGURING FOR A THERMAL PRINTER

The **SERIAL PORT** located on the Incubator side panel may be configured to communicate with a thermal printer. When configured to a thermal printer, the Controller will provide the following data:

- Incubator Number (refer to Paragraph 2.6.4).
- Air and Set Point Temperature (C500 will only provide Air Set Temperature) along with any changes.
- Current Air and Baby Temperature every 30 minutes (C500 will only provide Air Temperature).
- Any Alarm Messages that occur.
- Any changes to the Configuration Menu.
- Any change from Air Mode to Baby Mode or vice versa (C550 only).

All data will be transmitted in the current language selection (refer to Paragraph 2.6.11).

Change 2

The output transmission contains both synchronous and asynchronous data types.

Synchronous data are transmitted every 30 minutes and consist of a single transmission packet containing the current Air Temperature and current Baby Temperature. Asynchronous data are sent when something changes (mode change) or an alarm condition occurs.

The following table lists asynchronous events and the data transmission that follows. Please note that each transmission is prefaced with a series of control codes to the printer characteristics to select emphasized mode, double wide mode, and double strike mode as follows:

CCS (control codes sequence) = **ESCEESCW1ESCG**

ESC	(Escape)	27 (hex)
LF	(Line feed)	0A (hex)
CR	(Carriage Return)	0D (hex)

For the table below, xxx.x is the ASCII value of temperature. Example: 36.1 (if Degree C selected) of 101.8 (if Degree F selected). In addition, Y is the ASCII character "C" or "F" to denote either Degree C or Degree F mode.

ASYNCHRONOUS EVENT

TRANSMISSION DATA

Set Temperature Change	CCSET POINT: xxx.x YLFLF
Air Temperature Too High Alarm	LFCCAIR TEMP TOO HIGHLFLF
Change From Baby Mode	CCSBABY MODELFLFCC/SSET POINT: xxx.x YLFLF
Baby Temp Too High Alarm	LFCCBABY TEMP HIGHLFLF
Baby Temp Too Low Alarm	LFCCBABY TEMP TOO LOWLFLF
Change from Baby to Air Mode	CCSAIR MODELFLFCCSET POINT: xxx.xYLFLF
Needs Service Now Alarm	CCSNEEDS SERVICE NOWLFLF

The following lists the data transmission for a synchronous transmission of Air Temperature and Baby Temperature every 30 minutes. The transmission includes canceling emphasized mode, canceling double wide mode and selecting double strike mode.

ESCFESCWOESCGBABY TEMP = xxx.xY AIR TEMP = xxx.xYLF

Power-up information is transmitted when the Incubator Controller is initially energized. Note that this is the only time that the Incubator number will be transmitted. The following sequence is transmitted:

```

ESC@CRLF
CCSFACTORY DEFAULTS SETLFLF
CCS*****LFLF
CCSC550/C500 VER 1.8LFLF*
CCSINCUBATOR NUMBER=nnLFLF
CCSELF TEST PASSLFLF
CCS*****LFLF
ESCFESCWOESCGBABY TEMP=xxx.xY AIR TEMP=xxx.xYLFLF
CCSAIR MODE LFLF
CCSSET POINT: xxx.xYLFLF
    
```

*SOFTWARE VERSION NUMBER OF YOUR CONTROLLER MAY DIFFER

The **SERIAL PORT** may be configured to communicate with a thermal printer by performing the procedure described in Paragraph 5.3.9.

IMPORTANT: When a printer is connected to the **SERIAL PORT**, verify proper data transfer/duplication prior to use.

2.6.9 CONFIGURING FOR A DOT MATRIX PRINTER

The **SERIAL PORT** located on the Incubator side panel may be configured to communicate with a dot matrix printer. When configured to a dot matrix printer, the Controller will provide the following data:

NOTE: Baud Rate = 1200 — 8 Data, 1 Stop Bit.

- Incubator Number (refer to Paragraph 2.6.4).
- Air and Baby Set Point Temperature (C500 will only provide Air Set Temperature) along with any changes.
- Current Air and Baby Temperature every 30 minutes (C500 will only provide Air Temperature).
- Any Alarm Messages that occur.
- Any changes to the Configuration Menu.
- Any change from Air Mode to Baby Mode or vice versa (C550 only).

All data will be transmitted in the current language selection (refer to Paragraph 2.6.11).

The output transmission contains both synchronous and asynchronous data types.

Synchronous data are transmitted every 30 minutes and consist of a single transmission packet containing the current Air Temperature and current Baby Temperature. Asynchronous data are sent when something changes (mode change) or an alarm condition occurs.

The following table lists asynchronous events and the data transmission that follows. Please note that each transmission is prefaced with a series of control codes to the printer characteristics to select emphasized mode, double wide mode and double strike mode as follows:

CCS (control codes sequence) = **ESCEESCW1ESCG**

ESC	(Escape)	27 (hex)
LF	(Line feed)	0A (hex)
CR	(Carriage Return)	0D (hex)

For the table below, xxx.x is the ASCII value of temperature. Example 36.1 (if Degree C selected) of 101.8 (if Degree F selected). In addition, Y is the ASCII character "C" or "F" to denote either Degree C or Degree F mode.

ASYNCHRONOUS EVENT	TRANSMISSION DATA
Set Temperature Change	CCSET POINT: xxx.x YLFLF
Air Temperature Too High Alarm	LFCCAIR TEMP TOO HIGHLFLF
Change From Baby Mode	CCSBABY MODELFLFCC/SSET POINT: xxx.x YLFLF
Baby Temp Too High Alarm	LFCCBABY TEMP HIGHLFLF
Baby Temp Too Low Alarm	LFCCBABY TEMP TOO LOWLFLF
Change from Baby to Air Mode	CCSAIR MODELFLFCCSET POINT; xxx.xYLFLF
Needs Service Now Alarm	CCSNEEDS SERVICE NOWLFLF

The following lists the data transmission for a synchronous transmission of Air Temperature and Baby Temperature every 30 minutes. The transmission includes canceling emphasized mode, canceling double wide mode and selecting double strike mode.

ESCFESCWOESCGBABY TEMP = xxx.xY AIR TEMP = xxx.xYLF

Change 2

Power-up information is transmitted when the incubator controller is initially energized. Note that this is the only time that the Incubator number will be transmitted. The following sequence is transmitted:

```
ESC@CRLF
CCSFACTORY DEFAULTS SETLFLF
CCS*****LFLF
CCSC550/C500 VER 1.8LFLF*
CCSINCUBATOR NUMBER=nnLFLF
CCSSELF TEST PASSLFLF
CCS*****LFLF
ESCFESCWOESCBABY TEMP=xxx.xY AIR TEMP=xxx.xYLFLF
CCSAIR MODE LFLF
CCSSET POINT: xxx.xYLFLF
```

*SOFTWARE VERSION NUMBER OF YOUR CONTROLLER MAY DIFFER

The **SERIAL PORT** may be configured to communicate with a dot matrix printer by performing the procedure described in Paragraph 5.3.10.

IMPORTANT: When a printer is connected to the **SERIAL PORT**, verify proper data transfer/duplication prior to use.

2.6.10 DISABLING THE BABY MODE FUNCTION (C550 CONTROLLERS ONLY)

The Baby Mode function may be disabled on C550 Controllers; to disable the Baby Mode function, perform the procedure described in Paragraph 5.3.11.

IMPORTANT: When the Baby Mode Function of the C550 Controller has been disabled, and any Baby Mode key is pressed, the Message Center will display the message **CONFIGURATION ERROR**.

2.6.11 LANGUAGE SELECTION

The Controller Message Center has the capability to present messages in several different languages. These languages include English, French, Spanish, Italian, and German. Alternatively, English, Japanese, Swedish and Russian are also available. To select a language, perform the procedure described in Paragraph 5.3.12.

Change 3

2.7 OPERATIONAL CHECKOUT PROCEDURE

The Operational Checkout should be performed before the Incubator is first placed into service and after any disassembly for cleaning or maintenance.

2.7.1 CHECKING THE POWER FAILURE ALARM AND CONNECTING THE INCUBATOR TO THE AC LINE

WARNING: The Incubator should not be used if it fails to function as described. Service should be referred to qualified personnel.

CAUTION: Make sure that the building power source is compatible with the electrical specifications shown on the right side of the Incubator and VHA Stand. For proper grounding reliability, connect the power cord only to a properly marked 3-wire hospital-grade or hospital-use receptacle. Do not use extension cords.

Observe the following **CAUTIONS** when the Incubator is mounted on a VHA Stand:

CAUTION: HEAVY EQUIPMENT – To prevent injury or damage to the Incubator/Stand when transporting, use two persons of sufficient strength to adequately control the Incubator.

CAUTION: Always lower the Incubator to its lowest position prior to transport for optimum stability.

IMPORTANT: Before attempting to perform this procedure, refer to the Operator's Manual, Paragraph 4.1, **CONTROLS AND INDICATORS**, and Service Manual, Paragraph 3.2, *The Controller Message Center*.

A. CHECK THE POWER FAILURE ALARM

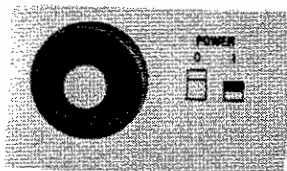

BEFORE CONNECTING THE INCUBATOR to the power source, press the **POWER** switch; the power failure alarm should sound and the **POWER FAIL** indicator on the Controller should light. This tests the operation of the power failure alarm circuit. Press the **POWER** switch a second time to silence the alarm.

POWER FAIL
ALARM
SYSTEM FAIL



Silence/Reset

B. CONNECT THE AC POWER CORD AND APPLY POWER

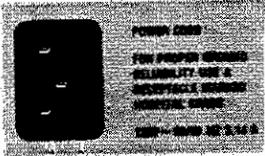

CONNECT THE AC POWER CORD directly to the Incubator when mounted on a Standard Cabinet Stand

OR

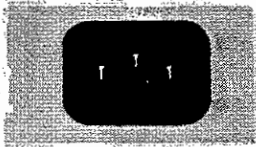

CONNECT THE AC POWER CORD to the VHA Stand ac power outlet when the Incubator is mounted on a VHA Stand (Option). The Incubator power cord should be connected to the VHA Stand receptacle to prevent accidental disconnection or damage when the Incubator is raised or lowered.



DEPRESS THE POWER SWITCH ON THE VHA STAND

AND/OR

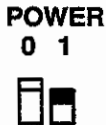
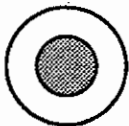

DEPRESS THE POWER SWITCH ON THE INCUBATOR. When ON, the switch is illuminated. When initially turned on, the unit performs a self-test. All indicator lamps light, the audible alarm is pulsed, the digital displays show eights (88.8) and the Message Center will display SETTING DEFAULTS and then SELF-TEST RUNNING. If the unit fails the self-test, the message NEEDS SERVICE NOW will appear. Refer the unit to service. Otherwise, refer to the Operator's Manual, Paragraph 4.4, Setting the Air Set Temperature, and set the Air Set Temperature to 34 °C.

C. ALLOW THE UNIT TO OPERATE WHILE PERFORMING THE HOOD/SHELL CHECKS

Change 2

2.7.2 OPERATIONAL CHECKOUT – HOOD/SHELL AND VHA STAND, IF SO EQUIPPED

WARNING: The Incubator should not be used if it fails to function as described. Service should be referred to qualified personnel.

Perform this Operational Checkout Procedure along with the Operational Checkout Procedure provided for the Controller before first placing the Incubator into service and after any disassembly or maintenance.

A. CHECK THE VHA STAND IF SO EQUIPPED

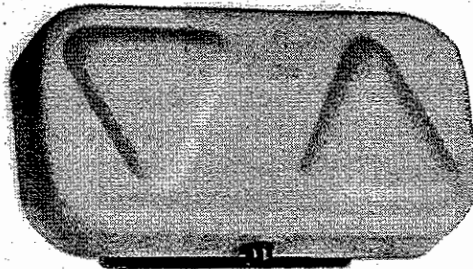

Turn on the Main Power switch. Use foot to press the right portion of the VHA Stand Up/Down switch to raise the stand to the maximum height. Press and hold the left portion of the VHA Stand Up/Down Switch to lower the stand to the minimum height. Verify the stand operates smoothly and readjust to desired height.

B. CHECK THE HOOD HINGE AND LATCH OPERATION

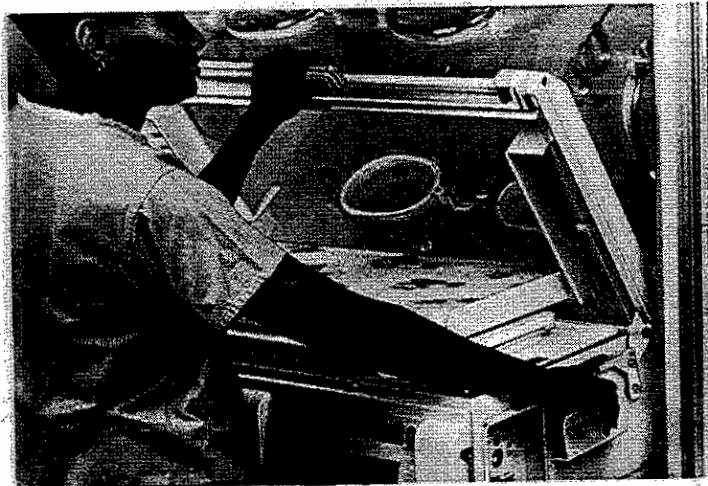

Using the Hood Lift handle, slowly tilt the Hood back until the Hood Latch engages. Close the Hood by releasing the Hood Latch.

Change 2

C. CHECK THE ACCESS PANEL DETENT AND INCUBATOR NOISE LEVEL

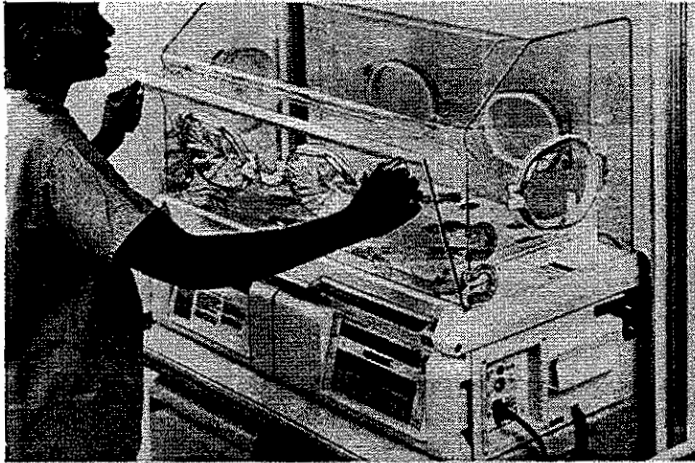

Rotate both latch/releases inward and open the Access Panel; the Air Curtain Cover should rise slightly as the Access Panel opens, and the detents should create a noticeable "drag" during initial movement of the panel. Pivot the Access Panel to the full open position (hanging straight down). Listen inside the Patient Compartment to confirm no unusual sounds (Fan Motor/Impeller Noises) are present.

D. CHECK THE AIR CURTAIN COVER

Remove Mattress Tray by lifting it straight up to clear the rails on the hood baffles and then withdrawing it through the front of the Incubator. Check that the rear curved edge of the Air Curtain Cover is retained by the 1/4-inch rod between the Mattress Tray rails and that the front edge is about 1 inch above the Main Deck.

E. CHECK THE MAIN DECK



WARNING: Do not lift the main deck or touch the heater when performing the following step. The heater can be sufficiently hot to cause burns.

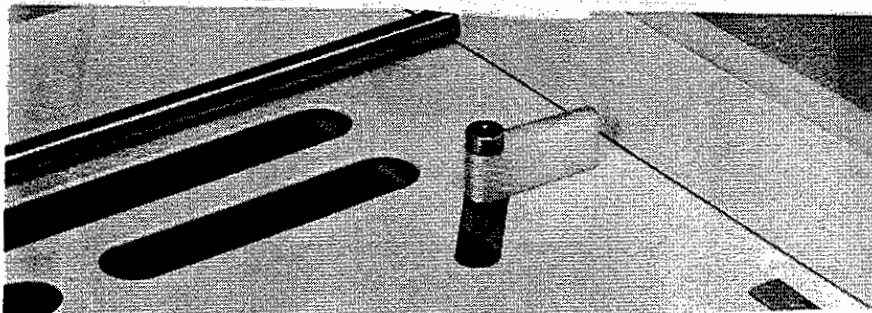

Pivot the Air Curtain Cover to the vertical position and check the Main Deck Retainer; position the retainer as shown. Lower the Air Curtain Cover and reinstall the Mattress Tray.

WARNING: The air curtain cover must be properly installed for correct temperature control.

F. CHECK THE IRIS ENTRY PORTS

Rotate the outer ring of the Iris Port(s); the iris should open and close as rotation is continued through 360 degrees.

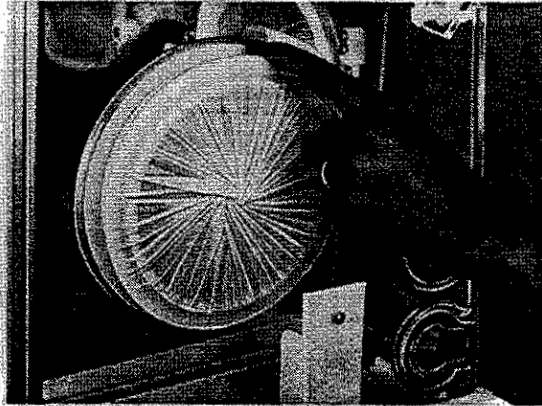

G. CHECK THE ACCESS PANEL LATCHES

Close the Access Panel and rotate both latches until fully engaged. Make sure both latches are fully engaged to avoid accidental opening of the Access Panel.

H. CHECK THE ACCESS DOOR LATCH

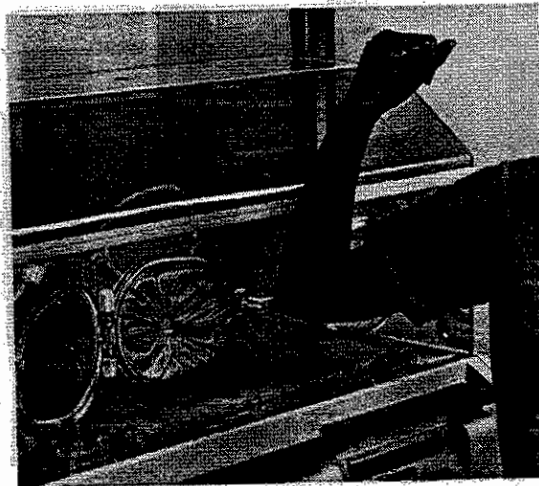

Press the door release of each Access Door simultaneously. Each Access Door should swing open. Close the doors and check for proper latching and quietness.

Change 2

I. CHECK THE MATTRESS ELEVATORS

IMPORTANT: The Elevators permit positioning the infant in the Trendelenburg or Reverse Trendelenburg position. Do not elevate both ends of the mattress at the same time except for possible use during magnification X-ray procedures. Never leave the infant unattended while both elevators are raised.

PNEUMATIC TILT

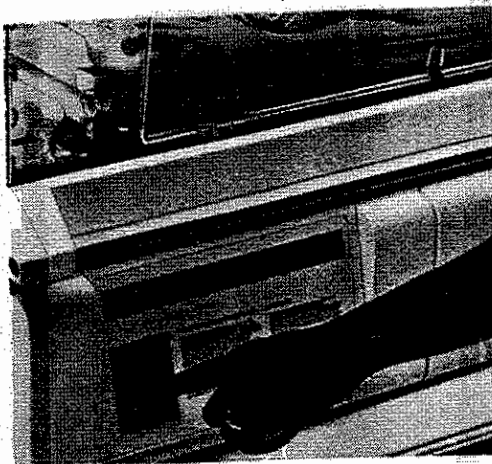
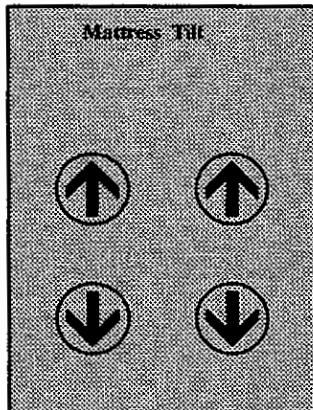

Press and hold the right-hand **up** arrow to raise the Mattress until it stops. The right end of the Mattress should be at a 9° angle. Press and hold the right-hand **down** arrow until the Mattress stops. The Mattress should be level. Repeat the procedure using the left-hand **up** and **down** arrows.

NOTE: The Mattress Elevators will be inoperative if the DISS fitting located on the rear panel of the Shell is not connected to an active source of wall air. Refer to the Controls and Indicators, Paragraph 4.1.4, and Section 2, Installation, for details. If a source of wall air is not available or in the event of a pneumatics related failure, the Manual Override of Pneumatic Tilt procedure described below should be employed.

MANUAL OVERRIDE OF PNEUMATIC TILT

1. Deflate the Bellows until the mattress is level.
2. Grasp the left Stabilizer Bar and raise the Mattress Tray Holder up and lock it in place by attaching the Lock-Up Clip to the Pin on the front Stabilizer Bar Retainer. To release the tray, push the Stabilizer Bar forward and then gently lower it. Raise the right side of the mattress Tray and lock it in place with the Lock-Up Clip. Release the tray and gently lower it.

MANUAL TILT (IF SO EQUIPPED)

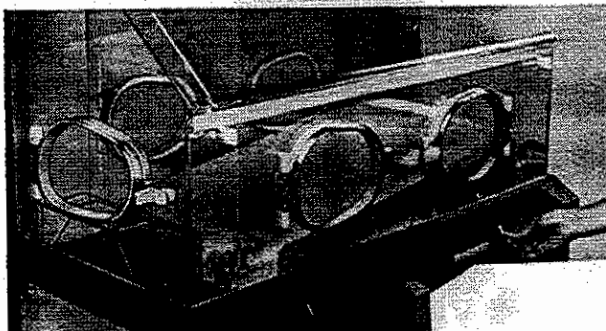

Rotate the right mattress tilt mechanism handle clockwise until it stops. The right end of the mattress should be at a 9° angle. Rotate the handle counterclockwise until it stops. The mattress should be level. Repeat the procedure using the left mattress handle.

Change 2

J. CHECK MATTRESS TRAY OPERATION

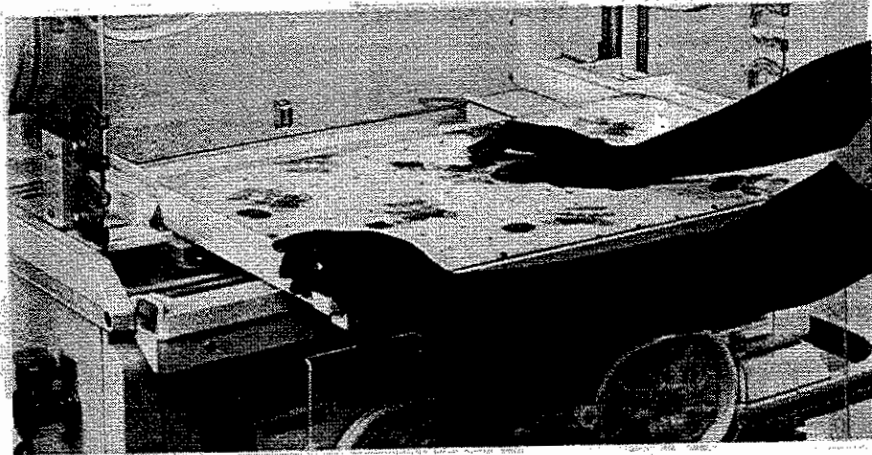

Slide out the mattress tray to the fully extended position. Lean on the Mattress Tray to make sure it is properly supported to provide a firm infant platform.

K. CHECK THE AIR INTAKE MICROFILTER

WARNING: A dirty Air Intake Microfilter may affect oxygen concentrations and/or cause carbon dioxide build-up. Check filter on a routine basis and change at least every three months.

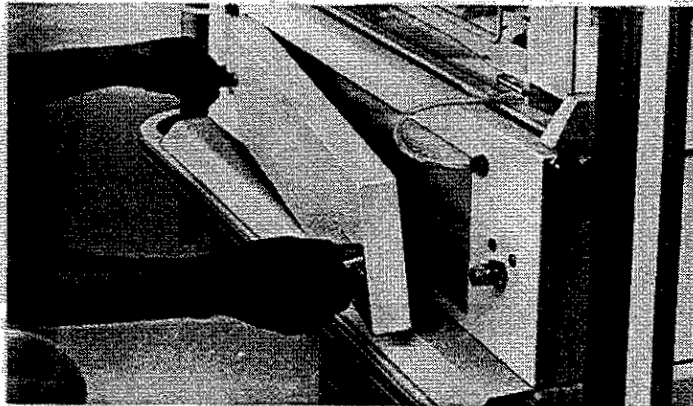

Loosen the two thumbscrews of the Air Intake Filter Cover and remove the cover. Inspect the microfilter; if visibly dirty, replace it. Refer to Section 4, Cleaning and Maintenance, for additional instructions.

Change 2

L. CHECK THE OXYGEN INPUT VALVE FILTER

Check the oxygen Input Valve Filter Cartridge once every four months and replace it if the ends are gray or black. Refer to the Service Manual and qualified service personnel.

M. CHECK THE AIR/OXYGEN SYSTEM

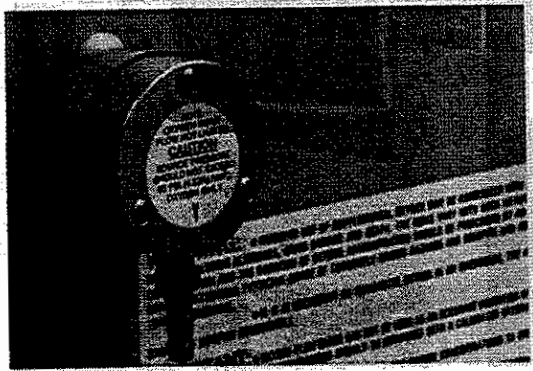

Introduce a carefully measured 8 lpm of oxygen into the Oxygen Input Valve, then monitor levels within hood to verify that they reach the predicted level as indicated on the Filter Cover Assembly.

Change 2

2.7.3 OPERATIONAL CHECKOUT – CONTROLLER

WARNING: The Incubator should not be used if it fails to function as described. Service should be referred to qualified personnel.

IMPORTANT: Before attempting to perform this procedure, refer to Operator's Manual, Paragraph 4.1, **CONTROLS AND INDICATORS**, and Service Manual, Paragraph 3.2, **THE CONTROLLER MESSAGE CENTER**.

IMPORTANT: If the ambient temperature is 17.5 °C or lower, the air temperature and baby temperature displays will be blank until the ambient temperature rises above 17.5 °C. If the ambient temperature is 15.5 °C or lower, the alarm message "NEEDS SERVICE NOW" will appear in the Message Center and the audible alarm will sound until the ambient temperature rises above 15.5 °C and the unit is turned off, then on.

Perform this Operational Checkout Procedure along with the Operational Checkout Procedure provided for the Hood/Shell before first placing the Incubator into service and after any disassembly or maintenance.

A. CHECK THE AIR CONTROL MODE OF OPERATION

With all access openings closed, allow the Incubator to warm up to the **Air Set Temperature** (33 °C); it should take less than one hour. While the unit is warming up, suspend the Auxiliary Probe through the hole in the top of the Incubator Hood and position the patient probe on the center of the mattress surface. **Do not connect the probe plugs to the receptacles.** When the **Air Temperature °C/°F** Display has stabilized, the number of **Heater Power %** Indicator lamps illuminated will typically be reduced to no more than six. Check that the digital display remains within 0.5 °C of Set Temperature for 15 minutes after stabilization.

B. CHECK THE AIR SET TEMPERATURE ALARM

Refer to the Operator's Manual, Paragraph 4.4, Setting the Air Set Temperature, and set the Set Temperature to 31 °C. The Message Center should display SET POINT UPDATED, then AIR TEMP TOO HIGH, followed by the message ALARM SILENCED. In addition, the **ALARM** Indicator should be on. In approximately four minutes the audible alarm should sound.

Change the Set Temperature to 37 °C; the current alarm should cancel. The Message Center should display SET POINT UPDATED, then AIR TEMP TOO LOW, followed by the message ALARM SILENCED. In addition, the **ALARM** Indicator should be on. In approximately eight minutes the audible alarm should sound. Return the Set Temperature to 33 °C.



Air Set Temperature



Set Point Display



Set Point Display

POWER FAIL

ALARM

SYSTEM FAIL



Silence/Reset

Change 4

C. CHECK THE AIR AUXILIARY PROBE

Insert the Auxiliary Probe connector into the AIR AUXILIARY PROBE receptacle. When the **Air Temperature °C/°F** Display has stabilized, no more than six **Heater Power %** Indicator lamps will typically be lit. Check that the digital display remains within 0.5 °C of Set Temperature for 15 minutes after stabilization.

D. CHECK THE BABY CONTROL MODE OF OPERATION

Connect the Patient Probe plug to the **PATIENT PROBE** receptacle and select the **Baby Mode** of operation. Refer to the Operator's Manual, Paragraph 4.3, and set the Baby Set Temperature to 36 °C. Locate the sensor to control air temperature above center mattress. If the set point alarm starts, depress the **Silence/Reset Key**. When the **Skin Temperature °C/°F** Display has stabilized, the number of **Heater Power %** Indicator lamps illuminated will typically be reduced to no more than six. Check that the digital display remains within 0.5 °C of Set Temperature for 15 minutes after stabilization.

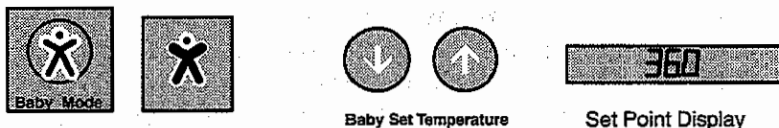

E. CHECK THE BABY SET TEMPERATURE ALARM

Allow Incubator temperature to stabilize at 36 °C. Refer to the Operator's Manual, Paragraph 4.3, Setting the Baby Set Temperature, and set the Set Temperature to 37.5 °C. The Message Center should display SET POINT UPDATED, then BABY TEMP TOO LOW, followed by the message ALARM SILENCED. In addition, the **ALARM** Indicator should be on.

Change the Set Temperature to 34.0 °C; the current alarm should cancel. The Message Center should display SET POINT UPDATED, then BABY TEMP TOO HIGH, followed by the message ALARM SILENCED. In addition, the **ALARM** Indicator should be on. In approximately four minutes the audible alarm should sound. Return the Set Temperature to 36 °C.

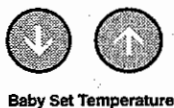

Set Point Display



Set Point Display

POWER FAIL

ALARM

SYSTEM FAIL



Silence/Reset

Change 4

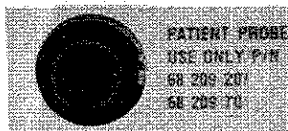
F. CHECK THE BABY TEMP PROBE FAIL ALARM

POWER FAIL

ALARM

SYSTEM FAIL



Silence/Reset

Disconnect the Patient Probe from the receptacle. The audible and visual alarms should activate, the **Baby Temperature °C/°F** Display should blank, and the **Heater Power %** Indicator lamps should all go off. When the Skin Probe is reconnected, the Incubator should return to normal operation after the **Silence/Reset** Key is pressed.

G. CHECK THE AIR FLOW ALARM

Set the **POWER** switch to OFF. Remove the Controller from the Incubator. Remove the fan impeller from the fan motor shaft and reinstall the Controller in the incubator. Reinsert the temperature probes. Set the **POWER** switch to ON and wait for the end of the self-test cycle. Within 5 minutes, the NO AIR FLOW message should appear, an audible alarm should sound, and all **Heater Power %** lights should go out. Reinstall the fan impeller and restore the Incubator to normal operating condition before proceeding.

CAUTION: The Heater will be hot; avoid touching it.

H. CHECK THE MAXIMUM AIR TEMPERATURE

Select the **Baby Mode** of operation. Position the probe end of the Patient Probe outside the Incubator. Allow the Incubator to heat. If the BABY TEMP TOO LOW message appears and the alarm actuates, depress the **Silence/Reset** Key.

The Incubator should not heat above $37.5\text{ °C} \pm 0.4\text{ °C}$ (**Software Level 1.8 or higher with a US Designation, the temperature will be limited to $39.5 \pm 0.5\text{ °C}$**), as indicated on the **Air Temperature °C/°F** Display.

I. THE OPERATIONAL CHECKOUT IS COMPLETE

Change 2

(This page intentionally left blank)

Change 2

SECTION 3 TECHNICAL INFORMATION

3.1 SPECIFICATIONS

Specifications for the Isolette® Infant Incubators, Models C500 QT® and C550 QT®, are provided in Table 3.1. All specifications are subject to change without notice.

TABLE 3.1 SPECIFICATIONS

Power Requirements:	
Models C500 QT® and C550 QT®	120V ± 10%, 50/60 Hz, 500 W Max 100V ± 10%, 50/60 Hz, 500 W Max 220V ± 10%, 50/60 Hz, 500 W Max
Chassis Leakage Current, 100/120V Units	less than 100 µA
220V Units	less than 500 µA
Alarms:	
No Air Flow	Activated by fan failure or a failed (broken) Air Flow Sensor
Air Temp Probe	Activated by a failed Air Temperature or Auxiliary Probe
Baby Temp Probe (C550 QT® only)	Activated by a failed Baby Temperature Probe or if probe is disconnected from unit when operating in Baby Mode.
Needs Service Now	Activated by following conditions: Failed Air Flow probe, Failed High Temperature Probe, Internally detected Failures.
High Temperature	Activated if displayed temperature exceeds 39 ± 0.3 °C (Software Level 1.8 or Higher with a US Designation) All other units 39 ± 0.3 °C for set temps >37 °C or 37 ± 0.3 °C for set temps <37 °C
System Fail	System failure, refer unit to service
AIR or BABY TEMP TOO HIGH or TEMP TOO LOW	Activates if Baby* or Air Temperature fluctuates from set temperature as follows:
In Baby Mode*—Baby Temperature	+1.0 ± 0.3 °C -1.0 ± 0.3 °C
In Air Mode—Air Temperature	+1.5 ± 0.5 °C -2.5 ± 0.5 °C
Power Failure Alarm (Power Fail)	Activates if primary power to the incubator fails or the power cord is accidentally disconnected from the wall receptacle.

*Model C550 QT® only.

Change 2

TABLE 3.1 SPECIFICATIONS (Cont.)

Alarms (Continued)	
Silence/Reset:	
Silence	Can silence all alarms, including Power Failure Alarm; silences the TEMP TOO HIGH or LOW audible alarm for 15 minutes; alarm silence is automatically overridden if a subsequent alarm occurs within the period of silence.
Reset	Cancel High Air Temperature Air Flow or Probe Alarm if alarm condition no longer exists.
Audible Alarm Level	65 dBA minimum at a point 3 meters away 1.5 meters above floor
Audible Alarm Frequency	Tone 1—1000 Hz nominal Tone 2—1100 Hz nominal Tone 3—1250 Hz nominal Tone 4—1400 Hz nominal Tone 5—1600 Hz nominal
Temperature Control Ranges:	
Air Control Mode	20.0 to 39.0 °C
Baby Control Mode*	34.0 to 37.9 °C
Temperature Rise Time**	60 minutes
Temperature Variation**	within ≤ 0.2 °C
Temperature Overshoot**	0.5 °C maximum
Temperature Uniformity**	within 1.0 °C
Correlation of Indicated Air Temperature to Actual Incubator Temperature**	
(after Steady Temperature Condition** is reached)	± 0.8 °C
Temperature Control Accuracy	
Air	± 0.5 °C of set temperature up to 39.0 °C
Baby*	± 0.3 °C of set temperature up to 38.0 °C
Oxygen Concentration Range	Ambient to >95%
CO₂ Concentration within the Baby Compartment	>0.3%
Humidity (with no supplemental Oxygen being administered and Set Temperature >32 °C and ambient temperature 20–30 °C)	
50–60%	
Environmental:	
Ambient Operating Range	68 °F (20 °C) to 86 °F (30 °C)
Ambient Storage Range	–23 °F (–30 °C) +158 °F (+70 °C)
Humidity	5% RH to 95% RH (non-condensing)

*Model C550 QT® only.

**Refer to Table of Definitions and Symbols.

TABLE 3.1 SPECIFICATIONS (Cont.)

Nominal Dimensions:

Height from Floor C500/C550 QT®	141 cm (55.5")
Height from Floor C500/C550 QT® Model XL	140 cm (55")
Depth	59.44 cm (23.4")
Width	119.4 cm (47.0")

Nominal Weight (without Accessories and Standard Cabinet Stand) 86 kg (190 lbs)

Mattress Tilt

Trendelenburg/Reverse Trendelenburg	Level ± 9° Continuously Variable
---	-------------------------------------

Noise Level within Hood Environment < 55 dBA maximum with 45 dBA or less ambient

Air Velocity over Mattress Does not exceed 10 cm/sec (20 ft/min) within **Control Zone**.**

VHA (Vertical Height Adjustable) STAND – Optional

Power Requirements (including Incubator).....	120V, ± 10%, 60 Hz, 600 W, Nominal 220–240V, ± 10%, 50/60 Hz, 600 W, Nominal
Chassis Leakage Current (including Incubator) 120V units	less than 100 µA
Chassis Leakage Current (including Incubator) 220V – 240V units	less than 500 µA

Height Range (VHA Stand)

Low	60.3 cm (23.75")
High	81.9 cm (32.25")
Depth	53.3 cm (21.00")
Width	113 cm (44.50")
Weight	95.2 kg (210 lbs)
Height Range (Incubator Mattress)	
Low	87.6 cm (34.50")
High	109 cm (43.00")
Weight (with Incubator mounted)	140.6 kg (310 lbs)

Change 5

3.2 THE CONTROLLER MESSAGE CENTER

3.2.1 ALPHABETICAL LISTING OF ALARM, SYSTEM AND USER PROMPT MESSAGES ALONG WITH PAGE NUMBERS

A

AIR MODE, 3-9
AIR TEMP PROBE FAIL, 3-6
AIR TEMP TOO HIGH, 3-7
AIR TEMP TOO LOW, 3-7
ALARM ACKNOWLEDGED, 3-8
ALARM SILENCED, 3-8
AUDIO TONE C/F, 3-12
AUDIO TONE IS SET, 3-13

B

BABY MODE, 3-9
BABY TEMP PROBE FAIL, 3-6
BABY TEMP TOO HIGH, 3-7
BABY TEMP TOO LOW, 3-7

C

C500 SELECTED, 3-16
C500/550 VER 1.2, 3-17
C550 SELECTED, 3-16
CAUTION >37, 3-10
CELSIUS SELECTED, 3-11
CLEAR DIAG LOG C/F, 3-18
COM SET TO DOT PRN, 3-15
COMM SET REMOTE MON, 3-14
COMM SET TO NONE, 3-14
COMM SET TO THM PRN, 3-15
CONF DOT MAT PRN C/F, 3-15
CONF NO EXT INTF C/F, 3-14
CONF REMOTE MON C/F, 3-14
CONF THERMAL PRN C/F, 3-15
CONFIG AS C500 C/F, 3-16
CONFIG AS C550 C/F, 3-16
CONFIGURATION C/F, 3-11

D

DIAG LOG IS CLEARED, 3-19
DIAG LOG IS EMPTY, 3-18
DIAGNOSTICS, 3-11

E

ENGLISH C/F, 3-16
ENGLISH SELECTED, 3-17

F

FACTORY DEFAULTS SET, 3-14
FAHRENHEIT SELECTED, 3-11
FRENCH C/F, 3-16
FRENCH SELECTED, 3-17

G

GERMAN C/F, 3-16
GERMAN SELECTED, 3-17

H

HIGH TEMPERATURE, 3-6

I

INCUBATOR NUMBER = 01, 3-13
ITALIAN C/F, 3-16
ITALIAN SELECTED, 3-17

K

KEY LOCK TIME = 10, 3-12
KEYPAD IS LOCKED, 3-9
KEYPAD IS UNLOCKED, 3-10
KEYPD LOCK TIME C/F, 3-12

M

MEM AVAIL = 100%, 3-19

N

NEEDS SERVICE NOW, 3-6

NO AIR FLOW, 3-6

P

PRINT CONFIG C/F, 3-17

PRINT DIA C/F, 3-18

PRINTING CONFIG, 3-18

PRINTING DIAG LOG, 3-18

PROC SIL MINUTES = 15, 3-12

PROC SIL TIME C/F, 3-12

PROCEDURAL SILENCE, 3-8

R

RESTORE DEFAULTS C/F, 3-13

RUSSIAN C/F, 3-16

RUSSIAN SELECTED, 3-17

S

SELF-TEST PASS, 3-9

SELF-TEST RUNNING, 3-9

SET C550/500 C/F, 3-15

SET INCUB NUM C

SET LANGUAGE C/F, 3-16

SET POINT UPDATED, 3-10

SETTING DEFAULTS, 3-13

SETTING THE TIMER, 3-11

SHOW CONFIG C/F, 3-17

SHOW DIAG LOG C/F, 3-18

SHOW MEM AVAIL C/F, 3-19

SHOW S/W VER C/F, 3-17

SPANISH C/F, 3-16

SPANISH SELECTED, 3-17

SYSTEM INFO C/F, 3-17

T

TIME ELAPSED, 3-11

TIMER ACTIVE, 3-11

TIMER PAUSED, 3-11

TIMER RESET, 3-11

tone 1: C/F TO SET, 3-13

tone 2: C/F TO SET, 3-13

tone 3: C/F TO SET, 3-13

tone 4: C/F TO SET, 3-13

tone 5: C/F TO SET, 3-13

U

UP/DOWN TO ADJUST, 3-12

3.2.2 ALARM MESSAGES

The alarm messages that will appear in the TWENTY-CHARACTER MESSAGE CENTER are presented below. In the event that two or more alarms occur simultaneously, or one after the other, the messages that describe the alarms will be presented in an alternating sequence.

ALARM MESSAGE	DESCRIPTION
NEEDS SERVICE NOW	This message is displayed along with a continuous audible alarm to indicate that the Incubator has experienced a malfunction. Refer to Paragraph 5.6, Troubleshooting.
HIGH TEMPERATURE	This message is displayed along with an audible alarm to indicate that Incubator air temperature has reached 38.0 °C (40.0 °C for >37 °C Mode) (40.0 °C for 1.8 software or higher with U.S. designation). This alarm is not self-resetting, but can be silenced by the Silence/Reset key for a period of 5 minutes.
NO AIR FLOW	This message is displayed along with an audible alarm to indicate fan failure or short-circuited air flow sensor. This alarm is not self-resetting but can be silenced or by the Silence/Reset key for a period of 5 minutes.
AIR TEMP PROBE FAIL	This message is displayed along with a two-tone audible alarm to indicate a malfunctioning air temperature probe. This alarm is not self-resetting but can be silenced or reset by the Silence/Reset key.
BABY TEMP PROBE FAIL	<p>This message is displayed along with a two-tone audible alarm to indicate a malfunctioning baby temperature probe. This alarm is not self-resetting but can be silenced or reset by the Silence/Reset key.</p> <p>This alarm is also actuated if the baby temperature probe is disconnected while in BABY MODE.</p>

Change 4

NOTE: This Message applies to the C550 QT® only.

ALARM MESSAGE	DESCRIPTION
BABY TEMP TOO HIGH	<p>BABY MODE – This message is displayed along with a two-tone audible alarm to indicate that the baby's skin temperature is 1°C above the Baby Set Temperature.</p> <p><i>NOTE: This message appears on the C550 only.</i></p>
AIR TEMP TOO HIGH	<p>AIR MODE – This message is displayed along with a two-tone audible alarm to indicate that the Incubator air temperature is 1.5 °C above the Air Set Temperature.</p>
BABY TEMP TOO LOW	<p>BABY MODE – This message is displayed along with a two-tone audible alarm to indicate that the baby's skin temperature is 1 °C below the Baby Set Temperature.</p> <p><i>NOTE: This message appears on the C550 only.</i></p>
AIR TEMP TOO LOW	<p>AIR MODE – This message is displayed along with a two-tone audible alarm to indicate that the Incubator air temperature is 2.5 °C below the Air Set Temperature.</p> <p>BABY MODE – This message will also appear while operating in Baby Temperature Mode, if an Auxiliary Probe at room temperature is placed into a "warm" Incubator.</p>

IMPORTANT NOTES ON TEMP TOO HIGH AND TEMP TOO LOW ALARMS

NOTE: The Air and Baby Temperature Too High and Temperature Too Low Alarms are self-resetting; that is, if the alarm condition is corrected, the visual and audible alarms are automatically silenced and the Message Center is cleared.

NOTE: To silence the audible portion of the Air and Baby Temperature Too High and Temperature Too Low Alarms for 10 minutes, press the **Silence/Reset** key; the activation of other audible and visual alarms will not be affected during this silence period.

NOTE: The Air and Baby Temperature Too Low Alarms are disabled for up to 60 minutes after the unit is turned on. The Incubator should reach Set Point Temperature within the 60-minute time span; the alarm is automatically enabled. If the Incubator has failed to reach Set Point Temperature within 60 minutes, the alarm will sound.

NOTE: In addition, the Air and Baby Temperature Too High and Temperature Too Low Alarms are silenced for a specific amount of time after the operator raises or lowers the Baby Set Temperature or the Air Set Temperature from a current Incubator temperature. The time that the alarms remain silenced varies with the amount of change (either plus or minus) from the current Incubator temperature. As a general rule, the greater the change from the current Incubator temperature, the longer the alarms will remain silenced. If the Incubator fails to reach the new set temperature after the specified time, the alarm will sound. Refer to Section 3, Figure 3.3, for specific times the alarms are silenced versus the amount of change from the current Incubator temperature.

Change 1

ALARM MESSAGE

DESCRIPTION

ALARM ACKNOWLEDGED

This message indicates that the **Silence/Reset** key has been pressed in response to an alarm condition.

ALARM SILENCED

This message appears after the message that describes an active alarm that has been silenced by pressing the **Silence/Reset** key. It also appears during Procedural Silence or when the operator has changed the Baby Set Temperature or the Air Set Temperature from a current operating temperature.

PROCEDURAL SILENCE

This message indicates that the user has pressed the **Silence/Reset** key to start the Procedural Silence timer. Procedural Silence can last up to 15 minutes. During this period, alarms inadvertently caused by routine procedures will be silenced automatically. To stop the Procedural Silence Timer, press the **Silence/Reset** key again.

NOTE: *The Procedural Silence time is factory-set for 15 minutes. Refer to Section 5, Paragraph 5.3.2, for a procedure to change the Procedural Silence time.*

3.2.3 SYSTEM AND USER PROMPT MESSAGES

The following System and User Prompt Messages that will appear in the TWENTY-CHARACTER MESSAGE CENTER are presented below:

SYSTEM/USER PROMPT MESSAGE	DESCRIPTION
SELF-TEST RUNNING	<p>This message appears when the unit is turned on. In addition, all Indicators are on, all segments of the Digital Displays are lit and the audible alarm sounds.</p> <p><i>NOTE: If during the Self-Test any Indicators fail to come on, any segments of the Digital Displays fail to light, or the audible alarm does not sound, refer the unit to qualified service personnel.</i></p>
SELF-TEST PASS	<p>This message appears after the Incubator has completed the Self-Test program.</p>
AIR MODE	<p>This message indicates that the Incubator is operating in the Air Temperature Mode.</p>
BABY MODE	<p>This message indicates that the Incubator is operating in the Baby Temperature Mode.</p> <p><i>Note: This message will only appear on C550 Controllers.</i></p>
KEYPAD IS LOCKED	<p>This message appears when the following keys are pressed: >37°, Baby Set Temperature, Baby Mode, Air Mode, Air Set Temperature and °C/°F and the Keypad is locked. When the Keypad is locked, the Lock Symbol over the Keypad Lock key will be lit.</p> <p>This message will also appear when the Keypad is unlocked and the user presses the Keypad Lock key to lock the Keypad or the Keypad Lock Time Duration (this may be up to 10 minutes after the last Keypad key was pressed) has timed out.</p> <p><i>NOTE: The Keypad Lock Time Duration is factory-set for a period of 10 minutes. Refer to Section 5, Paragraph 5.3.3, for a procedure to set the Keypad Lock Time.</i></p> <p><i>NOTE: The Timer Set/Reset, Start/Stop and Silence/Reset keys are never locked.</i></p>

SYSTEM/USER PROMPT MESSAGE

DESCRIPTION

KEYPAD IS UNLOCKED

This message appears when the **Keypad Lock** key is pressed and the Keypad is unlocked. When the Keypad is unlocked, the **Lock Symbol** over the key will be off. The following keys become operative when the Keypad is unlocked: **>37°**, **Baby Set Temperature**, **Baby Mode**, **Air Mode**, **Air Set Temperature**, and **°C/°F**. The Keypad will remain unlocked until the **Keypad Lock** key is pressed or for up to 10 minutes after the last Keypad key was pressed.

***NOTE:** The Keypad Lock Time Duration is factory-set for a period of 10 minutes. Refer to Section 5, Paragraph 5.3.3 for a procedure to set the Keypad Lock Time Duration.*

***NOTE:** The **>37°** key will not become operative until the Baby Set Temperature or the Air Set Temperature has been set to 37°C. When the **>37°** key is selected, the **>37°** Symbol over the **>37°** key illuminates.*

SET POINT UPDATED

This message appears within 3 seconds after the Air or Baby Set Temperatures have been changed from a current operating temperature. Updating the set temperatures causes the Air or Baby Temperature Too High and Temperature Too Low Alarms to be silenced for a specific amount of time after the operator raises or lowers the **Baby Set Temperature** or the **Air Set Temperature** from a current operating temperature. The time the alarms remain silenced varies with the amount of change (either plus or minus) from the Incubator temperature. As a general rule, the greater the change in tenths of a degree from the current Incubator temperature, the longer the alarms will remain silenced. If the Incubator fails to reach the new set temperature after the specified time, the alarm will sound. Refer to Section 3, Figure 3.3, for specific times the alarms are silenced versus the amount of change from the current Incubator temperature.

CAUTION: TEMP > 37

This message appears when the **>37°** key is pressed to place the Incubator in the Temperature Override Mode of operation. **Baby Mode** 37 °C (98.6 °F) to 38 °C (100.4 °F) or **Air Mode** 37 °C (98.6 °F) to 39 °C (102.2 °F).

***NOTE:** The **>37°** key will not become operative until the Baby Set Temperature or the Air Set Temperature has been set to 37°C. When the **>37°** key is selected, the **>37°** Symbol over the key illuminates.*

Change 5

SYSTEM/USER PROMPT MESSAGE

DESCRIPTION

CELSIUS SELECTED

This message appears after the °C/°F key is pressed to change the **Baby Temperature °C/°F**, **Air Temperature °C/°F**, **Baby Set temperature** and **Air Set Temperature** displayed temperatures from Fahrenheit to Celsius.

FAHRENHEIT SELECTED

This message appears after the °C/°F key is pressed to change the **Baby Temperature °C/°F**, **Air Temperature °C/°F**, **Baby Set temperature** and **Air Set Temperature** displayed temperatures from Celsius to Fahrenheit.

TIMER ACTIVE

This message appears after the **Timer Start/Stop** key is pressed to start the Timer. It indicates that the Timer is running. Refer to the Operator's Manual, Section 4, Paragraph 4.5, Operating the Timer.

TIMER PAUSED

This message appears after the **Timer Start/Stop** key is pressed to stop the timer. It indicates that the Timer has stopped running. Refer to Operator's Manual, Section 4, Paragraph 4.5, Operating the Timer.

SETTING THE TIMER

This message appears when the operator is selecting a time. Refer to Operator's Manual, Section 4, Paragraph 4.5, Operating the Timer.

TIMER RESET

This message appears after the operator has pressed the **Timer Set/Reset** key to reset the Timer to zero. Refer to the Operator's Manual, Section 4, Paragraph 4.5, Operating the Timer.

TIME ELAPSED

This message appears after the Timer has counted down to 0 minutes or counted up to the minimum elapsed time. Refer to the Operator's Manual, Section 4, Paragraph 4.5, Operating the Timer.

DIAGNOSTICS

This message informs the operator that the Diagnostic Menu has been selected by simultaneously pressing the >37° and °C/°F keys during the SELF-TEST RUNNING message. Refer to Section 5, Paragraph 5.2, to select the Diagnostic Menu items.

CONFIGURATION C/F

This message informs the operator that the Configuration Menu has been selected from the main Diagnostic Menu. This message appears after the operator has selected the Diagnostic Menu by simultaneously pressing the >37° and °C/°F keys during the SELF-TEST RUNNING message. Refer to Section 5 for an explanation and a procedure to select the Configuration Menu.

SYSTEM/USER PROMPT MESSAGE

DESCRIPTION

PROC SIL TIME C/F
(PROCEDURE SILENCE TIME)

This message informs the operator that the Procedural Silence Time Menu has been selected from the Configuration Menu. Refer to Section 2, Paragraph 2.6.1, and Section 5, Paragraph 5.3.2, for an explanation and a procedure to select the Procedural Time Duration.

PROC SIL MINUTES = 15

(PROCEDURE SILENCE
MINUTES = 15)

This message appears in the Procedural Time Menu and prompts the operator to select a procedural silence time from 0 to 15 minutes by using the **Baby Set Temperature** or **Air Set Temperature** Up/Down Arrow keys. Refer to Section 2, Paragraph 2.6.1, and Section 5, Paragraph 5.3.2, for an explanation and a procedure to select the Procedural Time Duration.

KEYPD LOCK TIME C/F

(KEYPAD LOCK TIME)

This message informs the operator that the Keypad Lock Time Menu has been selected from the Configuration Menu. Refer to Section 2, Paragraph 2.6.2, and Section 5, Paragraph 5.3.3, for an explanation and a procedure to select the Keypad Time-to-Lock duration.

KEY LOCK TIME = 10

This message appears in the Keypad Time-to-Lock Menu and prompts the operator to select a Keypad Time-to-Lock from 0 to 10 minutes by using the **Baby Set Temperature** or **Air Set Temperature** Up/Down Arrow keys. Refer to Section 2, Paragraph 2.6.2, and Section 5, Paragraph 5.3.3, for an explanation and a procedure to select the Keypad Time-to-Lock duration.

AUDIO TONE C/F

This message informs the operator that the Audio Tone Menu has been selected from the Configuration Menu. Refer to Section 2, Paragraph 2.6.3, and Section 5, Paragraph 5.3.4, for an explanation and a procedure for selecting an alarm tone.

UP/DOWN TO ADJUST

This message appears in the Audio Tone Menu to prompt the operator to select one of five different audible alarm tones available by using the **Baby Set Temperature** or **Air Set Temperature** Up/Down Arrow keys. Refer to Section 2, Paragraph 2.6.3, and Section 5, Paragraph 5.3.4, for an explanation and a procedure for selecting an alarm audio tone.

SYSTEM/USER PROMPT MESSAGE

DESCRIPTION

TONE 1: C/F TO SET
TONE 2: C/F TO SET
TONE 3: C/F TO SET
TONE 4: C/F TO SET
TONE 5: C/F TO SET
AUDIO TONE IS SET

These messages appear in the Audio Tone Menu when the operator presses the **Baby Set Temperature** or **Air Set Temperature** Up/Down Arrow keys. Refer to Section 2, Paragraph 2.6.3, and Section 5, Paragraph 5.3.4, for an explanation and a procedure for selecting an alarm audio tone.

This message appears in the Audio Tone Menu after the operator has pressed the °C/°F key to enter the desired alarm tone. Refer to Section 2, Paragraph 2.6.3, and Section 5, Paragraph 5.3.4, for an explanation and a procedure for selecting an alarm audio tone.

SET INCUB NUM C/F
 (SET INCUBATOR NUMBER)

This message informs the operator that the Set Incubator Number Menu has been selected from the Configuration Menu. Refer to Section 2, Paragraph 2.6.4, and Section 5, Paragraph 5.3.5, for an explanation and a procedure to select the an Incubator number.

INCUBATOR NUMBER = 01

This message appears in the Set Incubator Number Menu to prompt the operator to select an Incubator number by pressing the **Baby Set Temperature** or **Air Set Temperature** Up/Down Arrow keys. It also appears after the operator has pressed the °C/°F key to enter the desired Incubator number. Refer to Section 2, Paragraph 2.6.4, and Section 5, Paragraph 5.3.3, for an explanation and a procedure for selecting an Incubator number from 01 to 99.

RESTORE DEFAULTS C/F

This message informs the operator that the Set Restore Factory Defaults Menu has been selected from the Configuration Menu. The defaults include Air Mode, Air and Baby Set Temperature, Procedural Time, Keypad Lock Time, Audio Tone and No External Interface. Refer to Section 2, Paragraph 2.6.5, and Section 5, Paragraph 5.3.6, for an explanation and a procedure to restore the factory default settings.

SETTING DEFAULTS

This message appears when the unit is turned on and in the Restore Defaults Menu and informs the operator that the Factory Defaults are being restored for Air Mode, Air and Baby Set Temperature, Procedural Time, Keypad Lock Time, Audio Tone and No External Interface. Refer to Section 2, Paragraph 2.6.6, and Section 5, Paragraph 5.3.6, for an explanation and a procedure to restore the factory default settings.

SYSTEM/USER PROMPT MESSAGE

DESCRIPTION

FACTORY DEFAULTS SET

This message appears in the Restore Defaults Menu and informs the operator that the Factory Default Settings have been restored for Air Mode, Air and Baby Set Temperature, Procedural Time, Keypad Lock Time, Audio Tone and No External Interface. Refer to Section 2, Paragraph 2.6.5, and Section 5, Paragraph 5.3.6, for an explanation and a procedure to restore the Factory Default Settings.

CONF NO EXT INTF C/F

(CONFIGURE NO EXTERNAL
INTERFACE)

This message informs the operator that the Configure No External Interface Menu has been selected from the Configuration Menu. When performed, this procedure will disable the **SERIAL PORT** located on the Controller Side Panel. Refer to Section 2, Paragraph 2.6.6, and Section 5, Paragraph 5.3.7, for an explanation and a procedure to select the Configure No External Interface Menu.

COMM SET TO NONE

(COMMUNICATIONS SET TO
NONE)

This message appears in the Configure No External Interface Menu and informs the operator that the **SERIAL PORT** located on the Controller Side Panel has been disabled. Refer to Section 2, Paragraph 2.6.6, and Section 5, Paragraph 5.3.7, for an explanation and a procedure to select the Configure No External Interface Menu.

CONF REMOTE MON C/F

(CONFIGURE REMOTE MONITOR)

This message informs the operator that the Configuration for a Remote Monitor Menu has been selected from the Configuration Menu. When performed, this procedure will enable the **SERIAL PORT** located on the Controller Side Panel to communicate with a remote monitor. Refer to Section 2, Paragraph 2.6.7, and Section 5, Paragraph 5.3.8, for an explanation and a procedure to select the Configure a Remote Monitor Menu.

COMM SET REMOTE MON

(COMMUNICATIONS SET TO
REMOTE MONITOR)

This message appears in the Configuration for a Remote monitor Menu and informs the operator that the **SERIAL PORT** located on the Controller Side Panel has been configured to communicate with a remote monitor. Refer to Section 2, paragraph 2.6.7, and Section 5, Paragraph 5.3.8, for an explanation and a procedure to select the Configure a Remote Monitor Menu.

SYSTEM/USER PROMPT MESSAGE

DESCRIPTION

CONF THERMAL PRN C/F

(CONFIGURE THERMAL
PRINTER)

This message informs the operator that the Configuration for a Thermal Printer Menu has been selected from the Configuration Menu. When performed, this procedure will enable the **SERIAL PORT** located on the Controller Side Panel to communicate with a thermal printer. Refer to Section 2, Paragraph 2.6.8, and Section 5, Paragraph 5.3.9, for an explanation and a procedure to select the Configuration for a Thermal Printer Menu.

COMM SET TO THM PRN

(COMMUNICATIONS SET TO
THERMAL PRINTER)

This message appears in the Configuration for a Thermal Printer Menu and informs the operator that the **SERIAL PORT** located on the Controller Side Panel has been configured to communicate with a thermal printer. Refer to Section 2, Paragraph 2.6.8, and Section 5, Paragraph 5.3.9, for an explanation and a procedure to select the Configuration for a Thermal Printer Menu.

CONF DOT MAT PRN C/F

(CONFIGURE DOT MATRIX
PRINTER)

This message informs the operator that the Configuration for a Dot Matrix Printer Menu has been selected from the Configuration Menu. When performed, this procedure will enable the **SERIAL PORT** located on the Controller Side Panel to communicate with a dot matrix printer. Refer to Section 2, Paragraph 2.6.9, and Section 5, Paragraph 5.3.10, for an explanation and a procedure to select the Configuration for a Dot Matrix Printer Menu.

COMM SET TO DOT PRN

(COMMUNICATIONS SET
TO DOT
MATRIX PRINTER)

This message appears in the Configuration for a Dot Matrix Printer Menu and informs the operator that the **SERIAL PORT** located on the Controller Side Panel has been configured to communicate with a dot matrix printer. Refer to Section 2, Paragraph 2.6.9, and Section 5, Paragraph 5.3.10, for an explanation and a procedure to select the Configuration for a Dot Matrix Printer Menu.

SET C500/C500 C/F

This message informs the operator that the Set C500 or C550 Menu has been selected from the Configuration Menu. When performed, this procedure will configure the Incubator to operate as either a C500 (Air Mode Only) or C550 (Air and Baby Mode). Refer to Section 2, Paragraph 2.6.10, and Section 5, Paragraph 5.3.11, for an explanation and a procedure to select the Air/Baby or Air Mode Operation.

SYSTEM/USER PROMPT MESSAGE	DESCRIPTION
CONFIG AS C550 C/F	This message appears in the Set C500/C550 Menu and informs the operator that the Incubator will be configured in both the Air and Baby Modes. Refer to Section 2, Paragraph 2.6.8, and Section 5, Paragraph 5.3.11, for an explanation and a procedure to select the Set C550 /C500 Menu.
CONFIG AS C500 C/F	This message appears in the Set C500/c550 Menu and informs the operator that the Incubator will be configured in the Air Mode only. Refer to Section 2, Paragraph 2.6.8, and Section 5, Paragraph 5.3.11, for an explanation and a procedure to select the Set C550 /C500 Menu.
C550 SELECTED	This message informs the operator that to Configure the Incubator to operate in either Air or Baby Mode has been selected. Refer to Section 2, Paragraph 2.6.9, and Section 5, Paragraph 5.3.11, for an explanation and a procedure to change the Controller configuration.
C500 SELECTED	This message informs the operator that to Configure the Incubator to operate in Air Mode only has been selected. Refer to Section 2, Paragraph 2.6.9, and Section 5, Paragraph 5.3.11, for an explanation and a procedure to change the Controller configuration.
SET LANGUAGE C/F	This message informs the operator that the Language Selection Menu has been selected from the Configuration Menu. Refer to Section 2, Paragraph 2.6.10, and Section 5, Paragraph 5.3.12, for an explanation and a procedure to select one of several languages available via the Message Center.
ENGLISH C/F FRENCH C/F ITALIAN C/F SPANISH C/F GERMAN C/F RUSSIAN C/F	These messages appear in the Language Selection Menu and presents the operator with the languages available when the operator presses the Baby Set Temperature or Air Set Temperature Up/Down Arrow keys. Refer to Section 2, Paragraph 2.6.11, and Section 5, Paragraph 5.3.12, for an explanation and a procedure to select one of the several languages available via the Message Center. Alternatively, Japanese may be substituted for German and Russian.

SYSTEM/USER PROMPT MESSAGE

DESCRIPTION

**ENGLISH SELECTED
FRENCH SELECTED
ITALIAN SELECTED
SPANISH SELECTED
GERMAN SELECTED
RUSSIAN SELECTED**

One of these messages appears in the Language Selection Menu and confirms (after the °C/°F key is pressed) the operator's language selection. Refer to Section 2, Paragraph 2.6.11, and Section 5, Paragraph 5.3.12, for an explanation and a procedure to select one of the several languages available via the Message Center. Alternately, Japanese may be substituted for German and Russian.

SYSTEM INFO C/F
(SYSTEM INFORMATION)

This message informs the operator that the System Information Menu has been selected from the main Diagnostic Menu. Refer to Section 5, Paragraph 5.4.1, for an explanation and a procedure to select the System Information Menu.

SHOW S/W VER C/F
(SHOW SOFTWARE
VERSION)

This message appears in the System Information Menu and informs the operator that the Controller software version will be displayed when the °C/°F key is pressed. Refer to Section 5, Paragraph 5.4.2, for an explanation and a procedure to display the software version.

C500/550 VER 1.2
(C500/550 VERSION 1.2)

This message appears in the Show Software Version Menu and informs the operator of the Controller software version. Refer to Section 5, Paragraph 5.4.2, for an explanation and procedure to display the software version.

SHOW CONFIG C/F
(SHOW CONFIGURATION)

This message appears in the System Information Menu and informs the operator how the Incubator has been configured using the Configuration Menu when the °C/°F key is pressed. Refer to Section 5, Paragraph 5.4.3 for an explanation and a procedure to display the Show Configuration Menu.

PRINT CONFIG C/F
(PRINT CONFIGURATION)

This message appears in the System Information Menu and informs the operator how the Incubator has been configured will be printed when the °C/°F key is pressed. Refer to Section 5, Paragraph 5.4.4, for an explanation and a procedure to display the Print Configuration Menu.

SYSTEM/USER PROMPT MESSAGE

DESCRIPTION

PRINTING CONFIG
(PRINTING CONFIGURATION)

This message appears in the Print Configuration Menu and informs the operator how the Incubator has been configured is being printed. Refer to Section 5, Paragraph 5.4.4, for an explanation and a procedure to display the Print Configuration Menu.

SHOW DIAG LOG C/F
(SHOW DIAGNOSTIC LOG)

This message appears in the System Information Menu and informs the operator that the contents of the Diagnostic Log will be displayed when the °C/°F key is pressed. Refer to Section 5, Paragraph 5.4.5, for an explanation and a procedure to display the Diagnostic Log Menu.

DIAG LOG IS EMPTY

This message appears in the Diagnostic Log Menu and informs the operator that the Diagnostic Log is empty. Refer to Section 5, Paragraph 5.4.5, for an explanation and a procedure to display Diagnostic Log Menu.

PRINT DIAG LOG C/F

This message appears in the System Information Menu and informs the operator that the contents of the Diagnostic Log will be printed when the °C/°F key is pressed. Refer to Section 5, Paragraph 5.4.6, for an explanation and a procedure to display the Print Diagnostic Log Menu.

PRINTING DIAG LOG

This message appears in the Print Diagnostic Log Menu and informs the operator that the contents of the Diagnostic Log are being printed. Refer to Section 5, Paragraph 5.4.6, for an explanation and a procedure to display the Print Diagnostic Log Menu.

CLEAR DIAG LOG C/F

This message appears in the System Information Menu and informs the operator that the contents of the Diagnostic Log will be cleared when the °C/°F key is pressed. Refer to Section 5, Paragraph 5.4.7, for an explanation and a procedure to display the Clear Diagnostic Log Menu.

SYSTEM/USER PROMPT MESSAGE

DESCRIPTION

DIAG LOG IS CLEARED

This message appears in the Clear Diagnostic Menu and informs the operator that the contents of the Diagnostic Log has been cleared. Refer to Section 5, Paragraph 5.4.7, for an explanation and a procedure to display the Clear Diagnostic Log Menu.

SHOW MEM AVAIL C/F

This message appears in the System Information Menu and informs the operator the percent of memory available in the processor E² PROM will be displayed when the °C/°F key is pressed. Refer to Section 5, Paragraph 5.4.8, for an explanation and a procedure to display the Show Memory Available Menu.

MEM AVAIL = 100 %

This message appears in the Memory Available Menu and informs the operator of the percent of memory available in the processor E² PROM. Refer to Section 5, Paragraph 5.4.8, for an explanation and a procedure to display the Show Memory Available Menu.

3.3 THEORY OF OPERATION

3.3.1 GENERAL

This section contains a functional description and detailed theory of operation of the equipment. A system block diagram of the Controller is shown in Figure 3.2.

3.3.2 OVERALL FUNCTIONAL DESCRIPTION

The control of temperature, humidity, and oxygen concentration is achieved by means of the forced air circulation system as shown in Figure 3.1. A controlled amount of room air (approximately 35 lpm) is drawn through the air intake filter by means of the motor-driven impeller on the controller.

Supplemental oxygen, which may be introduced through the Oxygen Input Valve on the air intake filter cover, displaces a portion of room air to maintain the total gas intake (including oxygen) at 35 lpm. Since the amount of room air is controlled by the impeller/filter characteristics, and the amount of oxygen is controlled by the flowmeter setting, predictable oxygen concentrations within the Incubator can be attained. When oxygen flow exceeds 8 lpm, a valve within the oxygen inlet housing is activated to restrict air intake so that higher oxygen concentration can be achieved without excessive oxygen flow. Maximum air intake restriction is achieved at 12 lpm.

In addition to drawing fresh, filtered air into the Incubator, the impeller provides for the internal re-circulation at a much greater flow than that of the fresh gas inflow. The total flow of fresh and re-circulated air is directed past the air flow sensor and around the heater with a predetermined portion being directed over the humidity reservoir for humidification. When the Access Panel of the Hood is closed, the Air Curtain Cover is closed and all the air enters the infant compartment up through the slot at the right end of the main deck, as shown in Figures 3.1 and 3.1A. After circulating within the infant compartment, the air is then re-circulated down through the slot in the left end of the main deck, past the temperature sensing probe which encapsulates the air temperature control thermistor and a high air temperature alarm thermistor, and back to the impeller. When the Access Panel of the Hood is open, the Air Curtain Cover is raised permitting a portion of the air to flow upward past the opening (Figures 3.1 and 3.1A), creating a warm air curtain which minimizes the drop in air temperature in the Incubator.

The Model C550 QT® Incubator temperature is regulated using either Incubator air or baby temperature as the controlling parameter; the desired mode is selected by the front panel keys.

In either mode of operation, the heater output is proportional to the amount of heat required to maintain the desired temperature, and the relative amount of heat being provided is indicated by the number of illuminated **Heater Power %** lights on the front panel. Changes in the number of lamps illuminated indicates the amount of power required to maintain a given temperature. During baby temperature control, the Model C550 QT® provides an indication of the degree of the infant's dependency upon the temperature of its environment to maintain body temperature. Each mode of operation is described below.

Change 5

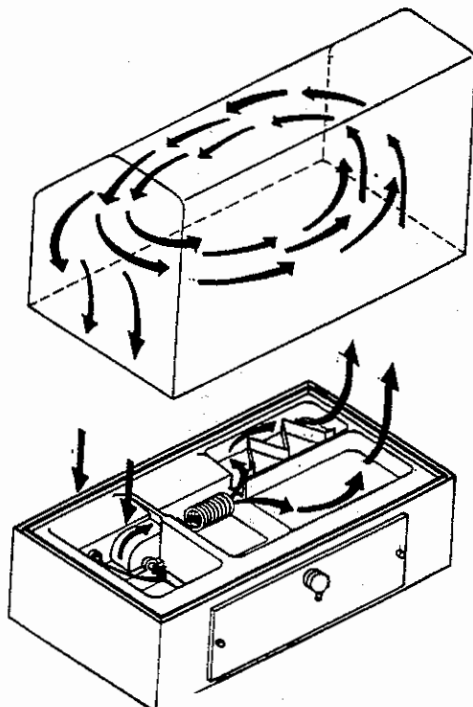

AIR CIRCULATION WITH INCUBATOR DOOR CLOSED

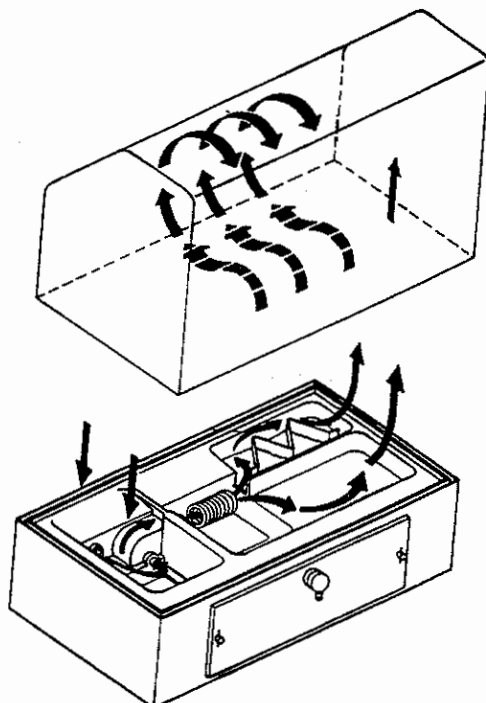

AIR CIRCULATION WITH INCUBATOR DOOR OPEN

FIGURE 3.1 AIR/O₂ CIRCULATION SYSTEM C500/C550 QT®

Change 5

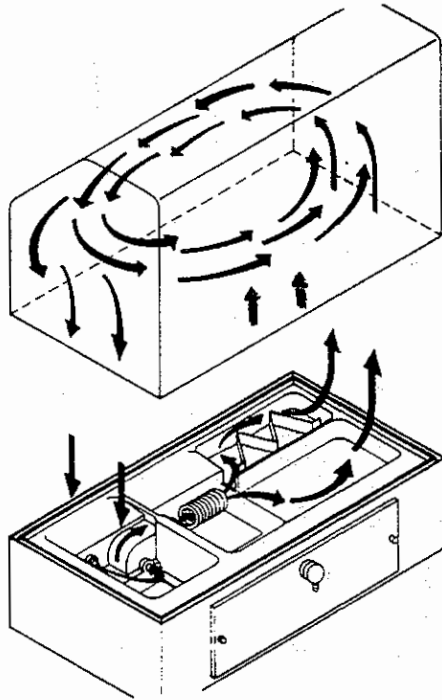

AIR CIRCULATION WITH INCUBATOR DOOR CLOSED

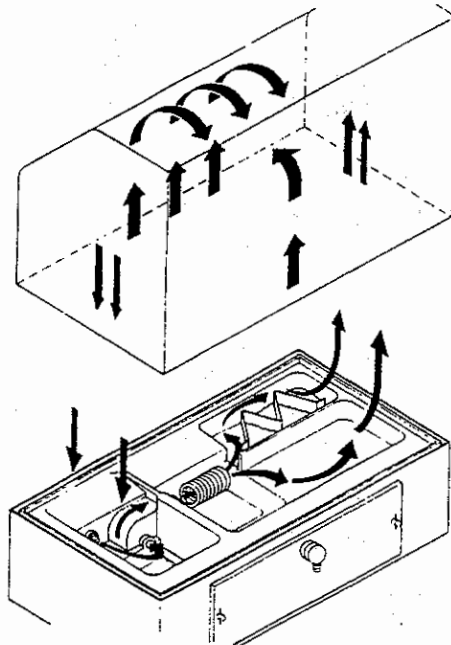

AIR CIRCULATION WITH INCUBATOR DOOR OPEN

FIGURE 3.1A AIR/O₂ CIRCULATION SYSTEM C500/C550 QT® XL

Change 6

(This page intentionally left blank.)

Change 5

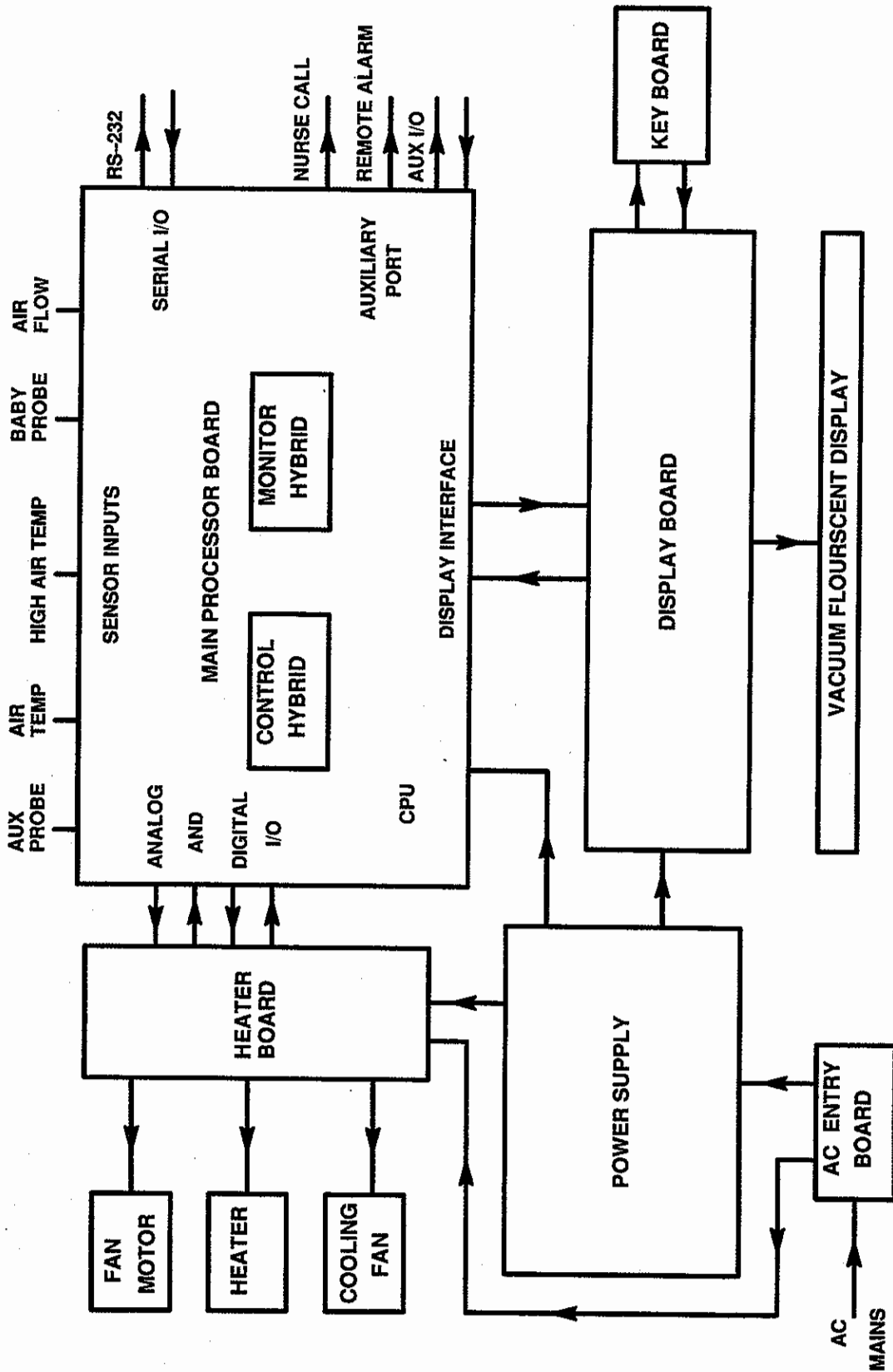

FIGURE 3.2 FUNCTIONAL BLOCK DIAGRAM

3.3.3 AIR TEMPERATURE MODE

In this mode of operation, the air temperature can be maintained from 20 to 37 °C (37 to 39 °C in Temperature Override Mode), as selected by the **Air Set Temperature** Up/Down Arrow keys on the front panel. The incubator air temperature is monitored by a probe located below deck and compared with the Air Set Temperature setting. The information from this probe is supplied to the heater control circuitry which proportions the heater output to maintain the Air Set Temperature setting. The actual air temperature is displayed on the **Air Temperature °C/°F** Display. A second sensor within the air temperature probe serves as a backup to limit the incubator temperature to 38 °C (**Software Level 1.8 or higher with a US Designation, the temperature will be limited to 40 °C**) for set points less than 37 °C and 40 °C for set points greater than or equal to 37 °C. At this temperature, a HIGH TEMP alarm is activated and the heater is shut off. If desired, an auxiliary air temperature probe can be used to control the incubator air temperature. This probe is suspended above the mattress through the weighing scale hole and plugged into a receptacle on the side of the incubator. When plugged in, the primary air temperature control probe is disconnected, but the backup sensor within the primary temperature probe remains connected. Thus, the auxiliary probe becomes the controlling element for the air temperature.

In the Air Temperature Mode of operation, the infant's temperature will be a function of the air temperature and the infant's ability to establish and maintain its own temperature. A small infant, or one with underdeveloped homeostatic control, may not be able to maintain a stable temperature at the desired level.

3.3.4 BABY TEMPERATURE MODE

In this mode of operation, the infant's temperature can be selected from 34 to 37 °C (37 to 38 °C in Temperature Override Mode) by the **Baby Set Temperature** Up/Down Arrow keys on the front panel. A temperature sensing probe is attached directly to the infant's skin; the information from the probe is supplied to the heater control circuitry which proportions the heater output to maintain the Baby Set Temperature. The Air Set Temperature does not control air temperature while in the **Baby Mode**, but air temperature is still displayed. The air temperature is still limited to 37.5 °C (**Software Level 1.8 or higher with a US Designation, the temperature will be limited to 39.5 °C**) for baby set temperatures less than 37 °C or 39.5 °C for baby set temperatures greater than 37 °C. If Air Temperature Mode has been selected while the baby probe remains connected, the **Baby Temperature °C/°F** Display will continue to display actual baby temperature, but will not control it.

If the probe is disconnected from its receptacle during **Baby Mode** of operation, the **Baby Temperature °C/°F** Display blanks, BABY TEMP PROBE FAIL appears in the Message Center, the **ALARM** Indicator illuminates and a dual tone audible alarm is activated. The High Temperature Alarm Sensor within the Air Temperature Probe remains in the circuit to limit the air temperature to 37.5 °C (**Software Level 1.8 or higher with a US Designation, the temperature will be limited to 39.5 °C**) for baby set temperatures less than 37 °C or 39.5 °C for baby set temperatures greater than 37 °C.

3.3.5 ALARMS

Alarms are provided for System Fail/Needs Service Now, Power Failure, No Air Flow, Air Temperature Probe Failure, Baby Temperature Probe Failure (C550 only), High Temperature, and temperature variation from Air or Baby Set Temperature. On power up, the Air or Baby Temperature Too Low Alarm is disabled for 60 minutes or until the temperature reaches Air or Baby Set Temperature, whichever occurs first; each of these alarms is described below.

NOTE: The Controller has five different Audio Alarm Tones available. Refer to Section 2, Paragraph 2.6.3, to select an Audio Tone.

NO AIR FLOW

A sensor located below deck in the normal air path of the fan controls this alarm. If air flow stops due to a fan failure, the temperature of the self-heated sensor rises which causes the NO AIR FLOW Message to be

Change 6

displayed in the Message Center and the **ALARM** Indicator illuminates with an audible tone. A short-circuited air flow sensor failure will also actuate the alarm within 9 to 18 seconds of the occurrence of the failure. This alarm is not self-resetting, but can be silenced by the **Silence/Reset** key for a period of 5 minutes.

HIGH TEMPERATURE

A second sensor within the Temperature Probe sounds this alarm if the Incubator temperature reaches 38.0 °C (40.0 °C for >37 °C Mode) (40.0 °C for 1.8 software or higher with U.S. designation). The **HIGH TEMPERATURE** Message appears in the Message Center and the **ALARM** Indicator illuminates along with an audible tone. This alarm is not self-resetting, but can be silenced by the Alarm **Silence/Reset** key for a period of 5 minutes.

POWER FAILURE

If primary power to the Incubator is interrupted for any reason, including a disconnected power cord, an audible alarm is activated and the **POWER FAIL** Indicator lights. This alarm can be deactivated by restoring the primary power, setting the Incubator **POWER** switch to Off, or pressing the **Silence/Reset** key.

SYSTEM FAIL/NEEDS SERVICE NOW

If an internal system failure occurs, the **SYSTEM FAIL** Indicator lights, **NEEDS SERVICE NOW** appears in the Message Center and the audible alarm sounds, the unit should be referred to service.

AIR TEMPERATURE PROBE FAILURE

Circuitry is provided to monitor the air and high temperature sensors for short-circuited, open-circuited, or disconnected conditions and the air flow sensor for open condition.

AIR TEMP PROBE FAIL appears in the Message Center, the **ALARM** Indicator light illuminates and an audible alarm sounds within 9 to 18 seconds to indicate a defective air temperature or auxiliary air sensor.

BABY TEMPERATURE PROBE FAILURE (C550 QT® only).

Circuitry is provided to monitor the baby sensor for short-circuited, open-circuited, or disconnected conditions.

BABY TEMP PROBE FAIL appears in the Message Center, the **ALARM** Indicator light illuminates and an audible alarm sounds within 9 to 18 seconds to indicate a defective baby sensor. This alarm is active only in **Baby Mode**.

AIR OR BABY TEMPERATURE TOO LOW or AIR or BABY TEMPERATURE TOO HIGH

The Air or Baby Temperature Too Low or Air or Baby Temperature Too High Alarm is actuated if the baby or air temperature fluctuates from the set temperature as follows:

Baby Temperature (C550 QT® only)	+1.0 ± 0.3 °C
	-1.0 ± 0.3 °C
Air Temperature	+1.5 ± 0 °C
	-2.5 ± 0.5 °C

A temperature below the Air or Baby Set Temperature is indicated by **AIR** or **BABY TEMP TOO LOW** in the Message Center, the **ALARM** indicator on, an audible alarm, and a low temperature reading. A temperature above the Air or Baby Set Temperature is indicated by **AIR** or **BABY TEMP TOO HIGH** in the Message Center, the **ALARM** indicator on, a pulsating audible tone, and a high temperature reading.

The Air or Baby Temperature Too High or Too Low Alarms are self-resetting; that is, if the alarm condition is corrected, the audible alarm is automatically silenced and the visual alarm indicator is turned off.

The audible portion of the Air or Baby Temperature Too High or Temperature Too Low Alarm can be silenced by pressing the **Silence/Reset** key; the activation of other audible and visual alarms will not be affected by use of the 10-minute audible alarm silence. When the alarm is silenced, the alarm lamp will remain on until the alarm condition is corrected. If the alarm condition is not corrected within 10 minutes, the audible alarm will be reactivated.

An Air Temperature Too Low Alarm will occur while operating in Baby Temperature Mode, if a "room temperature" Auxiliary Probe is placed into a "warm" Incubator. The alarm is indicated by the message AIR TEMP TOO LOW, the **ALARM** indicator being on and a continuous audible tone. The alarm is self-resetting and the audio portion can be silenced for 5 minutes (to allow the probe to warm up).

Specifically, the AIR TEMP TOO LOW Alarm will occur if the Incubator air temperature in **Baby Mode** is equal to or greater than 37 °C (for **Baby Set Temperature** <37 °C) or 39 °C (for **Baby Set Temperature** ≥ 37 °C) and an Auxiliary Probe temperature of 2 °C below the Incubator air temperature.

Please note that this function is only for **Baby Mode** of operation. If a cold Auxiliary Probe is placed into a warm incubator while in the **Air Mode**, the NEEDS SERVICE NOW message appears.

IMPORTANT: *Even though an alarm is instituted, it should be noted that the heater will be full on due to the fact that the Auxiliary Probe is cold and calling for full heat. If left unattended, the **HIGH TEMPERATURE** Alarm will activate at 38 °C (for **Baby Set Temperature** <37.0 °C) or 40 °C (for **Baby Set Temperature** ≥ 37.0 °C) to limit the internal temperature to an acceptable level. For **Software level 1.8 or higher with a US Designation**, the **HIGH TEMPERATURE** Alarm will activate at 40 °C for any **Baby Set Temperature**.*

CAUTION: Any time that the Auxiliary Probe is plugged into the Controller, it should be placed into the Incubator and allowed to stabilize for a **MINIMUM OF 5 MINUTES** prior to insertion into the Controller. This will not only prevent false alarms, but will also reduce the thermal change when switching from below deck to the auxiliary temperature probe control.

In addition, if it is desired to change the Air or Baby Set Temperature (either high or low) after the Incubator is in operation, the Temperature Too High and Temperature Too Low Alarms are automatically silenced for a specific amount of time after the operator raises or lowers the Air or Baby Set Temperature from the current operating temperature. The time the alarm remains silent varies with the amount of change (either plus or minus) from the current Incubator temperature. As a general rule, the greater the change from the current Incubator temperature, the longer the alarm will remain silent. If the Incubator fails to reach the new set temperature after the specified time, the alarm will sound. Refer to Figure 3.3 for specific times the alarm is silenced versus the amount of degree change from the current Incubator temperature.

Alternately, before changing the current Air Set Temperature, the operator may press the **Silence/Reset** key to place the unit in the Procedural Silence Mode of operation. In the Procedural Silence Mode, the Temperature Too High and Temperature Too Low Alarms are silenced for up to 15 minutes. Refer to Section 2 for setting the procedural time duration. To leave the Procedural Silence Mode, press the **Silence/Reset** key again.

REMOTE ALARM MODULE (ACCESSORY)

A Remote Alarm Module (Accessory) can be mounted atop an I.V. Pole (refer to Figure 1.1) to provide a visual indication that an alarm condition is in progress or has occurred.

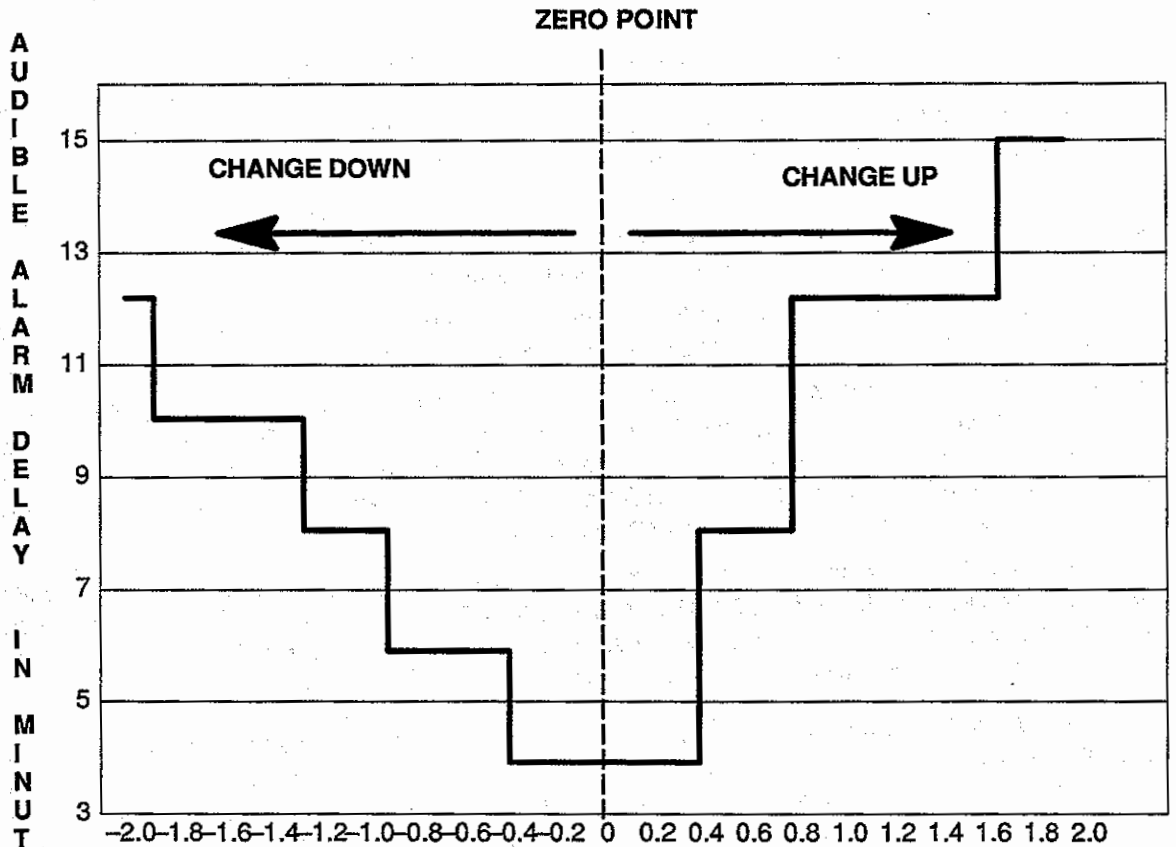

TEMPERATURE CHANGE IN °C FROM CURRENT INCUBATOR TEMPERATURE WHERE ZERO DEGREES REPRESENTS THE CURRENT INCUBATOR TEMPERATURE.

EXAMPLE: If the current Incubator Air Temperature is 36 °C (Zero Point) and the Operator raises the Air Set Temperature from 36 °C to 37.4 °C (a change up of 1.4 °C), the activation of the audible alarm will be delayed for 12 minutes.

FIGURE 3.3 TEMPERATURE TOO HIGH AND TOO LOW ALARMS – AUDIBLE ALARM DELAY TIME VERSUS CHANGE FROM CURRENT INCUBATOR TEMPERATURE

3.4 DETAILED CIRCUIT DESCRIPTION

3.4.1 AC ENTRY BOARD (REFER TO FIGURE 7.3)

GENERAL

The ac Entry Board provides ac power distribution for the series C500/550 Incubator Controllers. The printed circuit board may be configured for either 100/120 or 240V configurations, depending on the assembly.

AC MAINS INPUT

AC Mains voltage is inputted to the controller via J4, which is a combination IEC-350 type input receptacle and integrated EMI line filter. The third wire-protective ground termination is terminated from the receptacle directly to chassis ground. Protection against excessive current draw by the controller is provided by circuit breakers CB1 and CB4. The circuit breaker CB2 is installed (R1-R3 removed) only for European versions of the controller where protection in both sides of the line (hot and neutral) is required. In the case of non-European versions, CB2 is removed and R1-R3 are installed to maintain circuit continuity.

The ac voltage is applied to S1 pins P2 (ac hot) and P1 (ac neutral), which provides ON/OFF control for the system. The switched ac voltage at pins S1-2 (switched ac hot) and S1-1 (switched ac neutral) is then routed to J2-5 and J2-3 to provide power to the Power Supply Board and J3-1 and J3-3 to provide power to the Heater Board.

Functional ground connections required for the Power Supply Board are connected via the chassis mount screw terminations at E1 and E2 and are passed to the board via J2-1.

DC CIRCUIT

AC Mains Switch S1 contains an integral 24Vdc illuminated section which is illuminated when the switch is in the ON position and 24Vdc is applied to J1-1 (PGND) and J1-2 (+24V).

An additional set of switch contacts is connected to J1-3 (VSW and J1-4 (VBAT) which is used in the system to switch in the backup power supply for power failure.

3.4.2 HEATER BOARD (REFER TO FIGURE 7.4)

AC LINE MONITORING

AC line voltage is applied to the primary of the transformer T1 via protective circuit fuse F1. Secondary voltage is rectified by CR3 bridge and filtered by C6. Filtered voltage then is tapped off of R27 and applied to the non-inverting amplifier U4-8. The output U4-7 represents a scaled ac voltage and is always adjusted by R27 to 6.00 VDC at nominal ac line voltage.

DC MOTOR CONTROL

The motor control circuitry is designed to operate a 3-phase, 4-pole dc brushless motor which is used for air circulation in the Incubator. The dc motor is connected to the board via J4. Resistors R6, R19 and filter capacitor C3 are supplying power to the motor internal HALL effect position sensors. The differential analog outputs of the sensors are coming from J4-7 to J4-12, digitized by comparators U2A, U2B, U2C and applied to the inputs U3-7, U3-9 and U3-8 of the motor-driver chip U3. This chip provides all necessary decoding and commutation of the motor windings. The R22 resistor sets absolute maximum motor current to 2A. Motor velocity information is derived from the output U2-2. It represents a pulse train whose frequency is proportional to the motor's angular velocity. An F to V (frequency to voltage) converter is built around U1A, U1C, RN2E, RN2B, C5, CR1 and C4. The voltage at TP3 represents the motor's actual velocity. A reference motor velocity voltage is set by trim pot R26. Differential amplifier U2D compares these two signals and applies an error signal to the U3-4 input via resistor divider R17, R18. U3 then PWM (pulse width modulates) an output current to the motor winding, thus maintaining motor speed equivalent to the set point.

Change 1

POWER OK CIRCUITRY

This circuitry checks that ac power is present in the event of F1 fuse tripping. The voltage at the J1-4 will be maintained by the diodes CR5 or CR6 above 4.4 VDC level when either +5V or +6V (AC-VOLT) is present. If both voltages are not present, it means that there is no ac power supplied to the Incubator and POWER FAIL alarm will be activated.

AC OK CIRCUITRY

This circuitry verifies that AC-VOLT signal is valid and fuse F1 is OK. Normal voltage level at J1-2 is maintained by the ZENER diode CR7 and equal to 5.1 VDC. When F1 is blown, capacitor C6 is discharged through R27 and the voltage at J1-2 falls to 0V level.

OVERHEAT DETECTION

The purpose of the overheat detector circuit is to send an alarm signal (OVHEAT) to the main CPU board when the internal air temperature of the C550 rises above a predetermined temperature and, conversely, deactivate, the alarm signal when the temperature returns to an acceptable level. Hysteresis is incorporated in the design and hence the **OVHEAT** signal will become active before the temperature reaches 60 degrees C and will subsequently deactivate when the temperature drops below 50 degrees C.

The circuit is basically a comparator that measures the voltage across thermistor RT1. As the temperature rises, the resistance of RT1 decreases, as does the voltage across it. When the voltage reaches the reference voltage at pin U4-3, the output U4-1 will go high, U1-8 and J1-10 (OVHEAT) will go low, and U1-10 will go high. This will increase the reference voltage at U4-3, shifting the threshold temperature to a lower value.

3.4.3 MAIN BOARD (REFER TO FIGURE 7.5)

GENERAL

The Main PWA for the C500/550 Controller comprises the functions of temperature measurement, signal conditioning and conversion, display output control, user interface, an alarm generation through the use of hardware and software functions.

POWER SUPPLY

AC ENTRY

Voltage required to illuminate the power switch on the AC Entry PCB is via +24VDC connected to J9-2 and ground at J9-1. Battery voltage switching required for power failure alarm is routed out to J9-4 and comes back into the main board at J9-3.

DC SUPPLY

Power for the board is via connection to J1, which provides isolated voltages of +5V, +/-12V and +24V. Isolated -5VDC is also board generated by VR1, which makes use of -12V to generate the desired output.

MICRO-CONTROLLER

GENERAL

The uC U1 is used to interface to all user parameters, perform set point generation and monitor hardware functions/activity.

DATA BUS

The bi-directional data busses D0–D7 are active on pins 9–16 and are bussed to the program memory U2, hybrid interface buffer U11, display select buffer U4, display board interface buffer U7, and real time clock/RAM chip U19. The data bus is pulled up by resistor network RN4.

ADDRESS BUS

The bi-directional address busses A0–A7 are active on pins 51–58 and A8–A15 are active on pins 43–50. The address lines are bussed to U2 to access program memory, real time clock/RAM U19 and hardware decode logic PAL device U3.

CONTROL LINES

Control lines for I/O devices are located on U1–4 which is the enable line and U1–5 which is the R/W control signal.

PORT A

General purpose port A (pins 35–42) is used as I/O interface signals. LED–TEST is active when the uC is doing LED testing, ALM–SIL2 is active when the uC is silencing alarms (which is logically equivalent to the signal ALM–SIL from U11–12), OVHEAT–B which is a buffered input from the heater PCB, digital pot interfacing (pins 37–39), AC–OK coming from the heater board to indicate whether the circuit breaker has tripped and MOT–RPMB which is a frequency proportional to the motor speed.

PORT G

Port G (pins 20–27) is also used as I/O functions. The SOUND line is an audio drive signal to the alarm logic PAL U15. DIAG–F line is active when the uC senses internal or external problems. BUSY–B is used as the busy sense line return from the VFDM. KYPD is used to enable the keypad read on the front panel switches by the uC. SEL–DSPL is used to enable display select lines for the display PCB. HW–SEL is used as the select line for hardware I/O functions read (or written) by the uC. CLOCK is used for data I/O into U19. PROM is used as the program memory select line.

SERIAL COMMUNICATIONS

Serial communication signals appear as receive data into the uC (RXD pin 28), transmitted data out of the uC (TXD pin 29), serial data out from the monitor hybrid (MISO pin 30), serial data into the control hybrid (MOSI pin 31) and serial clock required for MISO and MOSI (pin 32).

A/D CONVERTER

The uC contains 8 channels of analog inputs which are A/D converted internally (pins 59–66). HITEST is a logic level input to determine whether the ring out probe is attached. HTR–EN is a logic signal indicating if heater is enabled. BAT–SENSE monitors the power failure backup power source as shifted by RNGD, E. HEAT–PWR is a relative indication of heater power where +4V equals full heater and OV is < 25 % heater power. Pin 60 senses both the +24V supply and –12V supplies. Pin 62 senses both the +12V and –5V supplies. AUX–ANLG provides an auxiliary input from J5. DEFAULT is used to sense whether power down was a result of switch depression or ac failure.

The internal A/D requires a positive and negative voltage reference for analog conversion, and these voltages are inputted to pins 68 and 67 respectively.

SUPPLY VOLTAGE

The uC is powered from pin 34 (positive supply + 5VDC) and ground reference at pin 1 and filtered by C7. All uC timing and signal generation is derived from the 8.0 MHz clock oscillator input at pin 6 from Y1-5. Pin 1 of Y1 is tied high to enable the oscillator.

INTERNAL OPERATION MODES

The uC internal operational modes and unused inputs are pulled high by RN1 at the pins U1-2,3,17,18,19.

DATA BUS PERIPHERALS

Program Memory: Program Memory for the uC operation is stored in U2. The chip is addressable up to 64K bytes with the bus width of 8 bits. The chip enable is developed from U1-20 and the output data is strobed onto the bus with the RD signal at pin 22.

RAM/Real Time Clock: Provision is made on the PWA for a real Time Clock and RAM chip (U19). The RD or WR control signals are used to input or output data from/to the device.

Watchdog Timer: Watchdog Timer U12 is used to monitor the uC activity. The signal on U12-7 is generated as a toggled line via PAL U3-17. If this line fails to "toggle" within a predetermined time limit, U12-6 becomes active which is fed into the PAL U3. Four successive watchdog signals will cause U3-18 to be asserted as a hardware failure. This device also generates the power up reset signal required by the uC and alarm logic clock/counters.

Decoding Logic: PAL U3 is wired to the address lines of the uC to map signals required for I/O interfacing. U3-21 (W-A/D) is used as the chip select for the buffer driving various outputs. Pin 20 (ANALOG) is used as the chip select for the buffer U8 which provides interfacing to the alarm logic levels. Pin 19 (DSPL) is used as the chip select for the display buffer U7 I/O. Pin 17 (WDT) is used to toggle the Watchdog Timer U12.

BUFFERS

Intra-Board Signals: Various signals are buffered within the main PWA for level conversion, interfacing, etc. IC's to provide these are buffer/driver chips U20 (hybrid to PAL), U8 (PAL to uC), U11 (uC to hybrids and PAL'S) and U6 (signal to signal).

Inter-Board Signals: Signals in/out of this PW going to other PWAs (heater board, display, etc) are buffered as a method to insure reliability by buffer/driver chips U4, 5 & 7 (uC to display PWA).

TEMPERATURE INPUTS

HYBRIDS

Monitor Hybrid: The monitor hybrid U21 is a single chip solution which provides temperature measurement interfacing to the uC. The hybrid contains an analog to digital converter which is under uC control via the control lines CONVST (U21-30), SCLK (U21-32) and MISO (U21-38). Internal to the hybrid is an analog multiplexer, which is controlled via lines CHSO, 1, 2 (U21-11, 7,16).

Logical inputs to U21 consist of AIR-MODE (U21-21) which is active for air mode control selected and GT37 (U21-23) which is active when a set point temperature in excess of 37 Degree C is selected.

Measured temperature set point data is inputted to U21-10 which has a signal of $-0.2V/$ Degree C.

Temperature data are inputted to U21 from thermistors and are located at the following pins:

- U21-19 Auxiliary Probe Monitor
- U21-25 High Temperature Probe
- U21-8 Skin Probe
- U21-3 Air Flow Probe

Alarm levels are detected internally and outputted as a logic state as follows:

- U21-33 Probe Failure
- U21-36 High Temperature Probe Failure
- U21-31 Air Flow Probe Failure
- U21-39 Air Flow Alarm

Precise temperature measurement is accomplished by incorporating a precision internal voltage reference which is outputted at U21-27.

The signal HTR-LIMIT (U21-5) provides an output which is used in the control hybrid as an air temperature limit set for either 37.5 Degree C or 39.5 Degree C. AIR-CTRL (U21-1) and SK-CTRL (U21-2) is converted by the internal A/D which allows the uC to also monitor the control temperatures outputted from the control hybrid.

SK-MON (U21-15) is a signal proportional to the skin temperature input (0.2V/Degree C) and air temperature is inputted at U21-9 as either auxiliary air temperature (U21-28) or normal air temperature.

Control Hybrid: The control hybrid U22 is a single chip solution for temperature control. The control set point T-SET (U22-31) is generated by the internal digital to analog converter under uC control via the control lines MOSI (U22-24), DTOA (U22-23) and SCLK (U22-22).

Selected control mode is inputted at U22-19. For air mode control, the thermistor connected to U22-35 will provide temperature control. For skin mode control, the signal connected to U22-32 will provide skin temperature control. Skin temperature control output signal is present at U22-34 with a signal equal to 0.2 V/Degree C. Air temperature control signal is present at U22-37 with a signal equal to 0.2V/Degree C.

Automatic heater power control is internally conditioned with a signal provided at U22-20, which is a dc voltage proportional to the ac line voltage.

In the internal control section, capacitance across U22-2 and U22-3 provides the integral term in the control loop. Additional capacitance to ground at U22-7 sets the pulse width modulated frequency for the solid state relay control outputted at U22-1.

Solid state relay cutout is controlled through a logical signal that can be inputted at U22-10. Additionally, alarm generation for air temperature too low alarm (U22-16) and air temperature too high alarm (U22-17) is generated in this hybrid.

A voltage at pin U22-5 sets the high air temperature limit to either 37.5 Degree C or 39.5 Degree C as sensed by the probe signal at U22-4.

A dc voltage proportional to the heater power is outputted at U22-8 and has the approximate range of 0-4VDC.

Calibration Check (Hybrids): Calibration of the hybrids can be confirmed by activation of the CALCHK line inputted to relay driver Q1-gate. When active, relay K2 switches precision resistors R10-13 corresponding to temperature values of 35.9 & 40.0 Degree C into both hybrids, allowing a software check of the hardware.

PROBES

AUXILIARY TEMPERATURE

The dual auxiliary probe can be inputted to the board via connection to J4. Switch S1 is mechanically linked in such a manner that when the dual auxiliary probe is connected to J4, the switch is activated. The switch is used to "multiplex" the auxiliary thermistor information to both the monitor and control hybrid instead of the normal below deck thermistor. EMI filter LN1 is used to reduce EMI radiation & susceptibility.

DUAL AIR

The high temperature thermistor section of the dual probe is connected to J7-1 and is always used to monitor temperature and high temperature alarm conditions except during calibration check. The alternate thermistor is connected to J7-3 and is normally connected to the control hybrid unless it is switched out by S1 in the event of auxiliary probe connection.

SKIN

The skin probe connection is made through J3-1 and J3-3 and is always connected to the monitor hybrid unless switched out during calibration test. EMI filter LN2 is used to reduce EMI radiation & susceptibility.

AIR FLOW

Air flow probe thermistor is connected to J6-1, 2 and is operated under self heated mode. A constant current source generated by R15, 16, Q2 and CR6 of a nominal 20 mA is used to shape the response of the thermistor. Thermistor input is into the control hybrid.

INTERFACE CIRCUITS

DISPLAY BOARD

Power for the Display Board (+5V and digital ground) are brought out on multiple pins on J1 to reduce IR drops from the current load of the display drivers. The +12V voltage is provided on J1-21 to drive low current devices on the display PCB. The power fail battery voltage comes into J1-27 (VBAT) and is routed out to J9-4 which is connected to an auxiliary contact on the Mains Switch. The other auxiliary contact of the Mains Switch is connected to J9-3 (VSW) which is routed to J1-31. These signals provide the power fail alarm logic voltages required. Additionally, the signal VSW is level shifted by RN9D & RN9E and fed into an A/D input of the uC U1-63 (BAT-SENSE). The signal DEFAULT (J1-23) is fed into the uC and is used to determine if power failure was a result of Mains Switch activation or other type of failure (cord disconnect, etc.).

The uC data bus lines DO-D7 are buffered through U7 and appear as the lines B0-B7 on J1. These signals are used to drive the VFDM connected to the Display Board. The signal FUTWR B (J1-36) comes from buffer U6 and is used as the VFDM write signal. The signal DIS-B (J1-40) is buffered by U6-16 and provides the select signal required by VFDM. The signal BUSY (J1-42) is returned by the VFDM and is used by the uC to determine whether the device is busy or ready for data.

Change 2

Interfacing to all display board elements is through the display enable signals EN1–EN6 which are decoded and buffered signals from U4. These signals provide the select function for the Display Board driver ICs. Data input to the Display Board drivers is via serial transmission by the signals MOSI–B (J1–22) and SCLK–B (J1–24) which are buffered out of U5.

Interfacing for the digital potentiometers on the Display Board is by the buffered signals from U5. A–LOAD–B (J1–26) is the selected signal, A–DATA–B (J1–28) is the serial data and A–CLK–B (J8–30) is the serial clock.

HEATER BOARD

Interfacing to the Heater PCB is via J2, which contains voltages required to drive the motor and signals back from the heater PCB to indicate status. The logic signal AC–OK (pin 2) is sensed by the uC to determine if the heater board protection circuit has tripped. Logic signal PWR–OK (pin 4) is used as the flag for power failure. Logic signal OVHEAT is a flag read by the uC to determine if the cooling fan is not providing sufficient cooling. MOT–RPM is a signal whose frequency is proportional to the motor speed. AC–VOLT is a dc signal which is proportional to the applied ac input line voltage and is used by the hybrids for heater power line voltage compensation. Heater control is via logic signal HTR–CUT, which, when active, disables the heater, and the signal SSR–CTRL, which is used as the pulse width modulated input to the solid state relay on the heater PCB.

SERIAL COMMUNICATIONS

The external SERIAL PORT J10 provides isolated serial RS–232 communications for transmitting and receiving serial data. Transmit data appear on pin 3 and receive data appear on pin 2. All other signals are tied to the active state (positive RS–232 levels) for interfacing. EMI filter LN6 is used to reduce EMI radiation and susceptibility.

The combination chip set of U9 and U10 (along with associated components) provide drive and conversion signals for the isolated channel. U9 interfaces directly to U1–28, 29 for receive and transmit data. U9–2,13 provide the drive capability to drive isolation transformer T1 which provides isolated power for U10. U9–3 is the transmit out line which drives opto–isolator U18 providing an isolated transmit line for U10–3. U9–10 is the receive input from the opto–isolator U23 which provides isolated received data from U10–5. Components CR1, C3 and C4 are used to rectify and filter the power signal from T1 and provide positive and negative isolated voltage levels required for communication.

The external SERIAL PORT J10 is connected as a DTE device with additional pins connecting signals required for the SSR control. Note that the SERIAL PORT signals are electrical isolated from the SSR control signals. The following Table provides pin connections along with a description:

Pin #	Pin Name/ Description	I/O	Levels
1	Data Carrier Detect	Input	Not Used
2	Receive Data	ISO Input	RS232
3	Transmit Data	ISO Input	RS232
4	Data Terminal Ready	ISO Output	RS232
5	Isolated Ground	ISO Gnd	
6	Data Set Ready	Input	Not Used
7	Request To Send	ISO Output	RS232
8	Clear to Send	Input	Not Used
9	Ring Indicator	Input	Not Used

Change 2

MULTI-PURPOSE OUTPUT

Remote Alarm Module (RAM): Connections made to the RAM are J5-1 to J5-6. Pins 1 and 5 are used to redundantly provide audio drive for the RAM. Pin 2 is the visual enable for the LEDs and pin 4 (MUTE) is a signal that, when asserted, silences the internal speaker. EMI filter LN3 is used to reduce EMI radiation and susceptibility.

Nurse Call: Connections are provided on J5-7, 8 as a contact closure for the Nurse Call option from K1 whose coil is driven by the signal N-CALL from U15-20. EMI filter LN4 is used to reduce EMI radiation & susceptibility.

Auxiliary: Connections are provided on J5-9 to J5-12 for signals into the system. J5-9 and J5-12 are power connections, J5-10 is an auxiliary digital input to the uC and J5-11 is an auxiliary analog signal into the uC. EMI filter LN5 is used to reduce EMI radiation and susceptibility.

If internal auxiliary connections are required, LN5 will be replaced by J11.

ALARM LOGIC

GENERAL TIMING

Alarm logic timing for alarm delays is provided by CMOS oscillator comprised of U17B, C,D which is set to oscillate at a nominal 3.3 Hz rate. This signal is fed from U17-8 into the divider U13, which provides reduced timing rates for the alarm logic. Power on reset is inputted to divider U13 to insure proper startup counter reset.

ALARMS

Delay: Asynchronous alarm delays are conditioned by programmable logic device U14, which internally generates the alarm delay for set point (U14-17), a logic output to indicate the 1 hour set point alarm disable time has expired (U14-14) and a logic out to enable the heater for temperature control (U14-16). Logical combinations are provided at U14-18,15 for alternate PAL logic control.

Set Point: Set point alarms are sensed, delayed, and logically conditioned by the programmable logic device U15. The signal ALARM-0 (U15-19) provides logic output to enable audio tones. The logic state for set point high alarm is outputted at U15-17 and set point low alarm level is outputted at U15-16.

Inputs to this device include CLK (U15-1) to generate internal time functions, LERR (U15-2) to indicate whether a latched alarm is active, ALM-SIL (U15-3) and ALM-SIL2 (U15-23) are used to silence the audio and HW-F (U15-11) are used to determine if hardware failure has occurred.

3.4.4 DISPLAY BOARD (REFER TO FIGURE 7.6)

GENERAL

The Incubator has two versions, the C500 and the C550. Both models are essentially the same with the C500 being a subset of the C550. The Display Board of the C500 has all the display LED's as the C550 with the exception of the following displays and their corresponding drivers:

C500 equals the C550 without:

- Baby Temperature
- Baby Control Temperature
- Baby Mode
- Baby Mode Degree C/F

Change 2

The function of the Display Board is to provide the Incubator with the following:

- Displays of temperature and other system information for operator interface purposes.
- Interface circuit for the Keypad.
- Alarm detection and annunciation including audio amplifier, tone control, and speaker.
- Battery, including charging circuit, to support alarm after normal power has failed.

POWER SUPPLY

The power required to run the Display Board is normally provided by the Incubator's main power supply. The Display Board only requires +5 and +12 volts dc and circuit ground from the main supply.

BATTERY SUPPLY

A battery is employed on the Display Board to power the audio alarm and its supporting logic in the event of main power failure. The battery is a Nicad rechargeable type that is charged by a circuit on the Display Board.

ELECTRICAL SPECIFICATIONS:

Capacity: 100 milli-amperes hours

Voltage: 4.8 volts

CHARGING CIRCUIT

The charging circuit consists of the following components:

U17A, U8C, U8D, CR4, CR5, R16, R23, R18, R20, R15, R21, R22, and RN5B.

The battery, BT1, is connected to the charging circuit through an isolated connection in the power switch. The switch connects VBAT with VSW, the junction of R23 and R21.

The basic function of the circuit is to charge the battery to about 6 volts. The minus input, pin 4, of comparator U17A is held at a reference voltage of about 5.7 volts. The battery voltage is applied to U17A pin 5 via R21. To eliminate the possibility of oscillation, hysteresis is added through R22.

When the battery is discharged, the voltage at U17A pin 5 is below that of pin 4 and pin 2 is low. A low on pin 2 results in a low on the gate of transistor U8C, turning it on. This supplies charging current to the battery through the channel of the transistor, diode CR4, and resistor R23. When the battery voltage surpasses that on U17A pin 4, pin 2 of U17A goes high, transistor U8C turns off and current to the battery is cut off. A small trickle charge, however, is always present because of resistor R16.

DISPLAY DRIVERS

All of the displays on the board are common anode. In all, except the System Fail and Power Fail Displays, the common anode is connected to the +5 volt supply through a two-diode drop that reduces the supply to about +3.8 volts. The segment cathodes are driven to ground by a National MM5450 display driver.

The MM5450 is a serial input, parallel latched output LED segment driver. When the enable is pulled low, serial segment drive data are clocked into a serial shift register in the device. When the latch is full, all the data are transferred to the latch/driver on the next clock pulse.

Change 2

All three interface signals (enable, data, and clock) are provided by the main controller board.

The System Fail and Power Fail light bars are controlled in a different manner. Their anodes are connected to either +5 volts or the battery through a FET. This is done so that they can be driven even when the +5 has been removed.

DISPLAYS

Only LED displays are used on the Display Board. Of these displays, there are two types; one is the numeric seven-segment type and the other is a light bar type.

KEYBOARD INTERFACE

The Incubator keyboard switches are arranged in a column/row matrix. Consequently, the keyboard scan circuitry drives the columns and reads the rows. There are two columns, COL-A and COL-B, and 6 rows labeled ROW-A through ROW-F.

The column drivers are provided by signal KYPD-B and 74LS05 inverters U7A, U7B, and U7C. When KYPD-B is driven high by the main board micro-controller, COL-A is driven low while COL-B is driven high. Since the output of 74LS05 is an open collector, pull-up resistors RN1 are needed. The row information is latched into U9, 74HC541, when signal R/W-B is driven high by the main board micro-controller.

The corresponding row output information, BO-7, is available on connector J1 pins 46,48,50,....60. Resistors RN2 provide static discharge protection.

SECTION 4 PREVENTIVE MAINTENANCE

4.1 GENERAL

This section provides cleaning and maintenance instructions. Where necessary, disassembly instructions are provided.

WARNING: Make sure that the oxygen supply to the Incubator is turned off and that the Incubator is disconnected from the oxygen supply when performing cleaning and maintenance procedures; a fire and explosion hazard exists when performing cleaning and/or maintenance procedures in an oxygen-enriched environment.

4.2 CLEANING

At a minimum, the incubator should be thoroughly cleaned and disinfected upon discharge of an infant. Cleaning can most effectively be accomplished by disassembling, then grouping the parts and/or assemblies in categories according to the method of cleaning required.

4.2.1 DISASSEMBLY FOR CLEANING

NOTE: For routine cleaning there is no need to separate the Hood/Base Assembly from the Cabinet Stand. If separation is necessary, refer to the Installation Section.



WARNING: The Controller heater can be sufficiently hot to cause burns; avoid removing the Controller or touching the heater until the unit has been switched off for at least 45 minutes.

A. REMOVE THE CONTROLLER. Disconnect the Power Cord and Probes from the side of the Incubator.

Change 7

NOTE: Refer to Figure 4.1 and slide the left-hand front panel to the left. Release the latch on each side of the Controller, then withdraw the unit from the Incubator.



FIGURE 4.1 REMOVAL OF CONTROLLER

B. REMOVE THE OPTIONAL HOOD INNER WALL. Remove the Inner Wall as described in Figure 4.2.

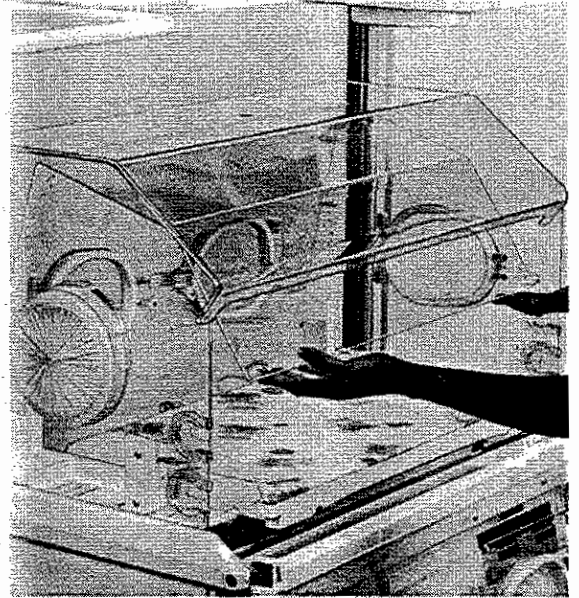
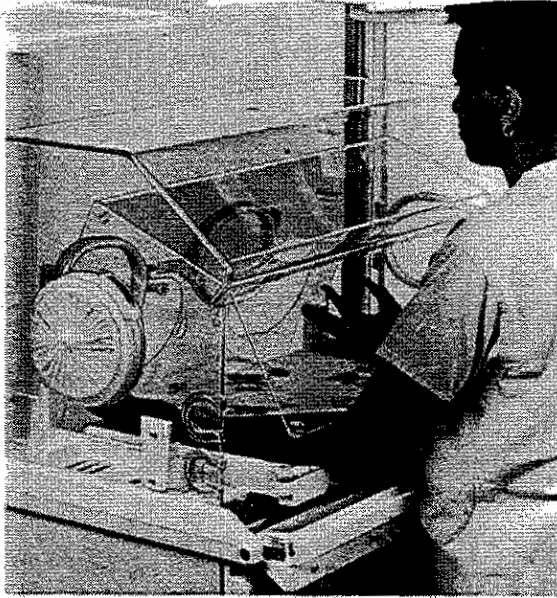

1. RELEASE FRONT OF INNER WALL by pushing slightly back in direction of hood slope, then down.

2. RELEASE REAR OF INNER WALL while resting front edge of inner wall on your arm, lift rear of inner wall, pull toward you to release, then lower.

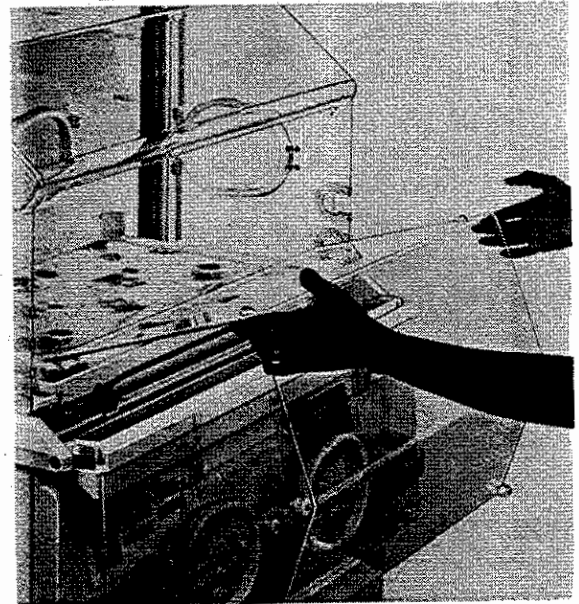
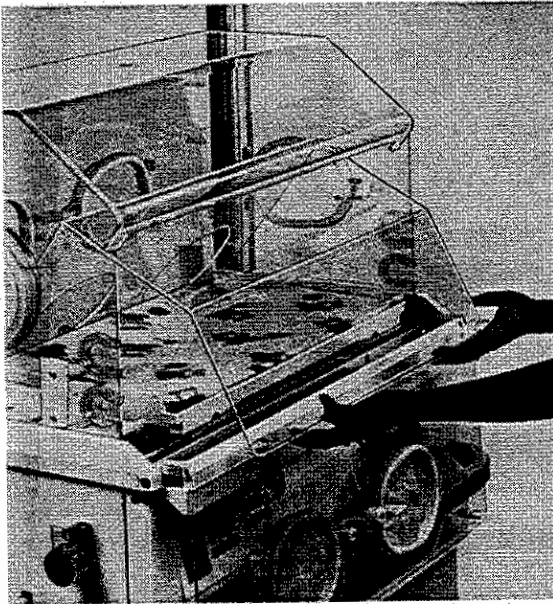

3. LOWER REAR OF INNER WALL AS FAR AS IT WILL GO.

4. REMOVE INNER WALL by lowering in direction shown.

FIGURE 4.2 REMOVAL OF OPTIONAL INNER WALL

- C. REMOVE ACCESS PANEL OPTIONAL INNER WALL.** Refer to Figure 4.3. With the Access Panel completely open, remove the Inner Wall by simultaneously pulling out at the top and pushing in the downward direction.

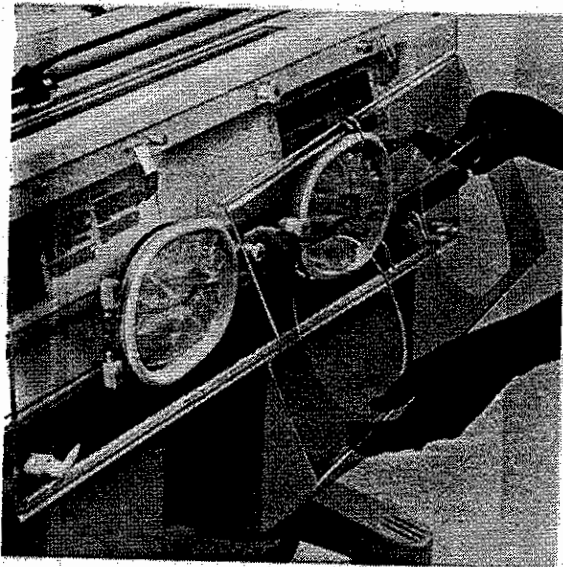

FIGURE 4.3 ACCESS PANEL OPTIONAL INNER WALL REMOVAL

- D. REMOVE MATTRESS TRAY AND AIR CURTAIN COVER.** Close the Access Panel and latch the Hood Assembly in the open position, then lift out the Mattress Tray. Remove and discard the disposable mattress cover.

Lift the front of the Air Curtain Cover, swing it toward the back of the Incubator past the vertical position until you feel it snap free, then slide it slightly forward to remove.

- E. REMOVE THE RIGHT AND LEFT MATTRESS LIFTING BELLOWS (PNEUMATIC TILT MODELS).** Refer to Figure 4.4 and remove the bellows tube from the fitting by **depressing the red collar**, then remove the tube. Remove the bellows from the Incubator.

OR

REMOVE THE MATTRESS TILT MECHANISMS (MANUAL TILT MODELS) by first loosening the two captive screws that secure them to the Main Deck.

- F. REFER TO SECTION 2, PARAGRAPH 2.2.2, STEP B,** and raise and then lock the Hood in place.

CAUTION: Before lifting Incubator Hood for cleaning, ensure that all mounted accessories on the Optional Rail System have been removed to prevent possible interference with the raised Hood.

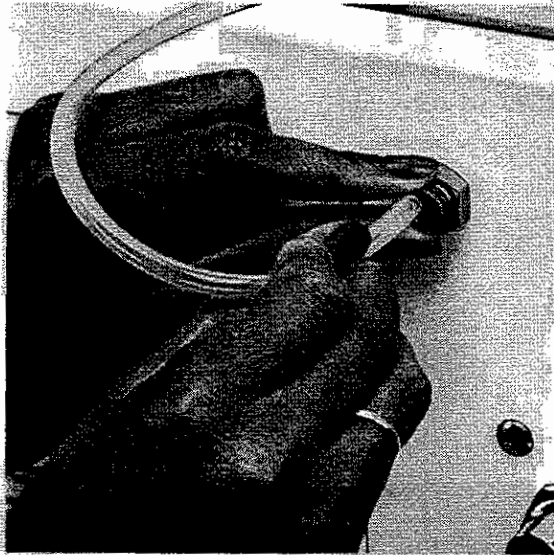

FIGURE 4.4 REMOVAL OF BELLOWS TUBE FROM COLLAR

- G. REMOVE MAIN DECK.** Rotate the Main Deck Retainer (Figure 4.5) parallel with the slot, then lift out the Main Deck and Hood Seat Gasket.

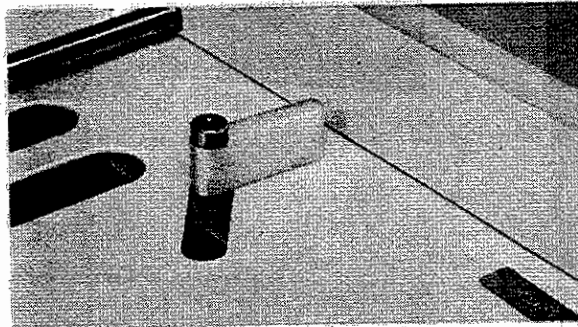

FIGURE 4.5 REMOVAL OF MAIN DECK

- H. REMOVE AIR INTAKE TUBE.** Grasp the Air Intake Tube (Figure 4.6), twist and pull it toward the front of the Incubator until the end of the tube clears the gasket. Remove the tube from the base assembly.

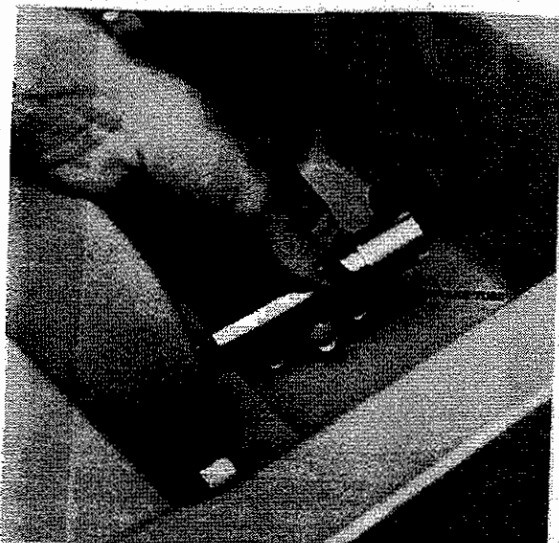

FIGURE 4.6 REMOVAL OF AIR INTAKE TUBE

- I. REMOVE DISPOSABLE ACCESS DOOR CUFF** from each Access Door Gasket by pulling it off from the outside; discard the cuffs.
- J. REMOVE ACCESS DOOR GASKETS** from each side of the hood by pulling them free.
- K. REMOVE TUBING ACCESS GROMMETS** from each side of the Hood by pulling them free.
- L. REMOVE DISPOSABLE IRIS ENTRY PORT SLEEVES** by pulling each Sleeve off the retainer rings; discard the sleeves.
- M. REMOVE THE AIR INTAKE MICROFILTER COVER** by loosening the two thumbscrews.

4.2.2 CLEANING

CLEANING AGENTS

An intermediate-level detergent/disinfectant registered by the U.S. Environmental Protection Agency should be used, but only after the incubator is empty and disassembled as described in Paragraph 4.2.1. When using any cleaning agent, follow the manufacturer's directions for use. After removing all solid wastes and contaminants from the disassembled parts, clean them as follows:

SKIN TEMPERATURE PROBE

Use a detergent/disinfectant to thoroughly clean all surfaces, then dry with a clean cloth or paper towel.

HUMIDITY CHAMBER AND FILL PIPE, AIR INTAKE TUBE, ACCESS DOOR GASKETS, TUBING ACCESS PORTS, AND MAIN DECK GASKET

Fill the humidity chamber with a detergent/disinfectant, then remove the W-shaped baffle from the chamber and dry it with a clean cloth or paper towel. Place the Air Intake Tube, Access Door Gaskets, Tubing Access Ports, and Main Deck Gasket into the solution.

NOTE: If necessary, a larger container may be used, but if the chamber is not used, then the Fill Pipe and Humidity Chamber must be cleaned separately.

Allow parts to soak as recommended by the manufacturer, then remove them and dry completely with a clean cloth or paper towel. Drain the Humidity Chamber, scrub it thoroughly, including all indentations, then dry the chamber and Fill Pipe (inside and out) with a clean cloth or paper towel.

Change 7

If it is necessary to remove the fill pipe for cleaning, rotate the Fill Pipe Assembly about 1/4 turn to the left. Loosen the thumbscrew that secures the Fill Pipe Bracket and rotate the bracket 1/4 turn to the left. Unscrew the Fill Pipe Assembly by rotating it counterclockwise as shown in Figure 4.7. Clean the Fill Pipe Assembly and the sleeve that becomes a loose part when the Fill Pipe Assembly is unscrewed.



FIGURE 4.7 REMOVAL OF HUMIDITY FILL PIPE ASSEMBLY

CONTROLLER

The portions of the Controller external to the controlled Incubator environment include the front panel and the top, bottom, and two sides of the chassis. Wipe these portions clean with a cloth dampened with a detergent/disinfectant.

CAUTION: Some chemical cleaning agents may be conductive and/or leave a residue which may permit a build-up of dust or dirt which may be conductive. Do not permit cleaning agents to contact electrical components. Do not spray cleaning solutions onto any of these surfaces.

The portions of the Controller that are within the controlled environment are on the rear surface. Included are the air temperature probe, the fan impeller, the heater, the gaskets, and the surface of the Controller to which these components are mounted.

CAUTION: Failure to clean could result in sufficient lint build-up to reduce airflow, which will affect temperature control and cause high oxygen concentrations.

1. Remove any lint build-up; pay particular attention to the fan impeller, heater, air temperature probe, and air flow sensor.
2. Clean these surfaces with a detergent/disinfectant, then dry with a clean cloth or paper towel.

NOTE: A disinfecting tank is available as an accessory from Hill-Rom Air-Shields to facilitate cleaning the rear surface of the Controller. Immerse the Controller rear surface into the tank after filling it with a detergent/disinfectant, then allow it to soak as recommended by the manufacturer.

MATTRESS TRAY, AIR CURTAIN COVER AND MAIN DECK

Use a detergent/disinfectant to clean all surfaces thoroughly, then dry with a clean cloth or a paper towel.

BELLOWS (PNEUMATIC TILT MODELS)

Remove all solid wastes and contaminants from the Bellows. When using any cleaning agent, follow the manufacturer's directions for use. If contaminants or cleaning agents enter the Bellows, it is recommended to discard the Bellows rather than disinfect and aerate the Bellows' interior.

MATTRESS TILT CONTROLS (MANUAL TILT MODELS)

Remove all solid wastes and contaminants from the Mattress Tilt Control. An intermediate-level detergent/disinfectant registered by the U.S. Environmental Protection Agency should be used to clean the mechanical mechanism. When using any cleaning agent, follow the manufacturer's directions for use.

HOOD AND CABINET STAND

Use a detergent/disinfectant to clean all surfaces of the hood thoroughly, including the inner wall and access door heat shield. Make sure to clean all holes, indentations, baffles, etc., then dry with a clean cloth or paper towel.

CAUTION:

- **Alcohol can cause crazing of the clear Acrylic Hood. Do not use alcohol for cleaning.**
- **Do not expose the hood assembly to direct radiation from germicidal lamps. Ultraviolet radiation from these sources can cause cracking of gaskets, fading of paint, and crazing of the clear Acrylic Hood.**

AIR INTAKE MICROFILTER

Do not attempt to clean or reverse the microfilter. Replace it if it is visibly dirty or older than 3 months. Before installing a new filter, clean the Microfilter chamber and cover with a detergent/disinfectant.

WARNING: A dirty Inlet filter may affect oxygen concentration and/or cause carbon dioxide build-up. Be sure the filter is checked on a routine basis commensurate with local conditions. Particularly, if the Incubator is used in an unusually dusty environment, more frequent replacements may be necessary.

4.2.3 REASSEMBLY AFTER CLEANING

NOTE: *Inspect all cleaned components for any breakage or cracks before reassembling into the Incubator. Harsh cleaning agents may attack some of the plastics used in the Patient Compartment.*

- INSTALL THE AIR INTAKE TUBE** (into the Base Assembly) by reversing the procedure shown in Figure 4.6.
- INSTALL THE MAIN DECK AND HOOD SEAT GASKET** into the Base Assembly as shown in Figure 4.8. Rotate the Main Deck Retainer (Figure 4.5) to secure the deck.

Change 7

C. INSTALL THE BELLOWS (PNEUMATIC TILT MODELS). Refer to Section 2, Paragraph 2.4, Installation of Mattress Tilt Bellows.

OR

INSTALL THE MATTRESS TILT CONTROLS (MANUAL TILT MODELS) on the Main Deck.

NOTE: There is a right-hand and left-hand tilt mechanism.

CAUTION: Be sure the two thumbscrews that hold the tilt mechanism to the deck are tightened securely.

D. INSTALL THE AIR CURTAIN COVER AND MATTRESS TRAY.

WARNING: The Air Curtain Cover must be properly installed for correct temperature control.

Hook the lip on the bottom rear of the Air Curtain onto the rod at the rear of the Main Deck Assembly, then lower the cover toward the front of the Incubator to the rest position. Close the Hood Assembly and check for proper operation of the Air Curtain Cover. The Air Curtain Cover is operating correctly if it rises slightly when the Access Panel is opened. Install the Mattress Tray by positioning it a few inches above the mattress rails, then lowering it straight down.

E. INSTALL THE DISPOSABLE MATTRESS COVER. Place a new disposable mattress cover over the mattress, then place the mattress onto the tray.

WRONG MAIN DECK POSITION—
Main deck placed up on gasket on one side, permitting air flow as shown by dashed line.

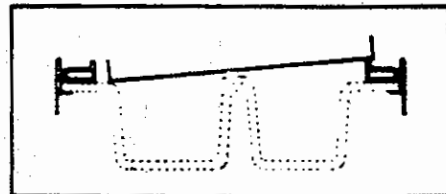

CORRECT MAIN DECK POSITION—
Main deck placed down on conditioning chamber top.

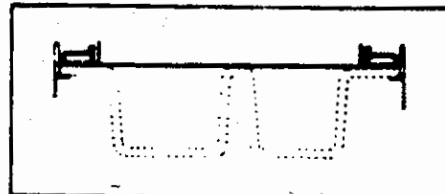
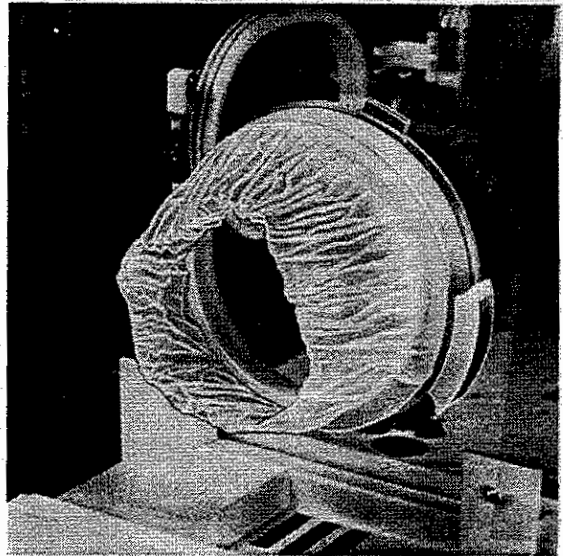
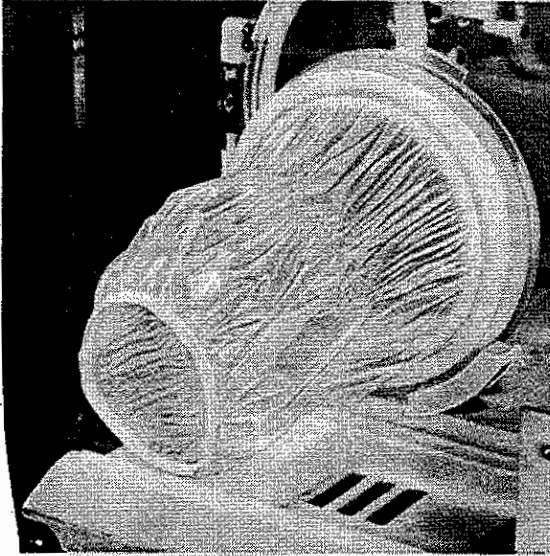

FIGURE 4.8 INSTALLATION OF MAIN DECK AND HOOD SEAT GASKET

Change 1

F. INSTALL DISPOSABLE IRIS ENTRY PORT SLEEVES. Install a new Iris Entry Port Sleeve as shown in Figure 4.9.

NOTE: If the Incubator is to be gas sterilized, wait until after sterilization to install new sleeves.



1. Install the smaller diameter elastic band of a new sleeve over the inner ring of the port housing.

2. Fold back and slip larger elastic band over the outer ring of the port housing.

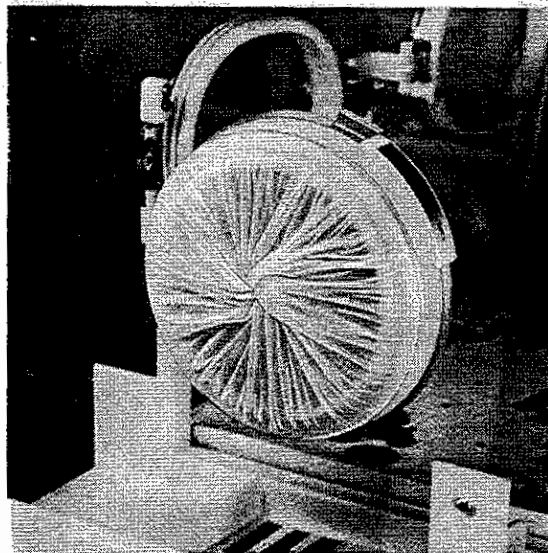

3. Rotate outer ring to close. If properly installed, the sleeve will open again if rotation is reversed.

FIGURE 4.9 INSTALLATION OF IRIS ENTRY PORT SLEEVE

- G. **INSTALL A TUBING ACCESS PORT** into the front edge of each side of the Hood. Replace if distorted or torn.
- H. **INSTALL AN ACCESS DOOR GASKET** behind each Access Door, as shown in Figure 4.10.

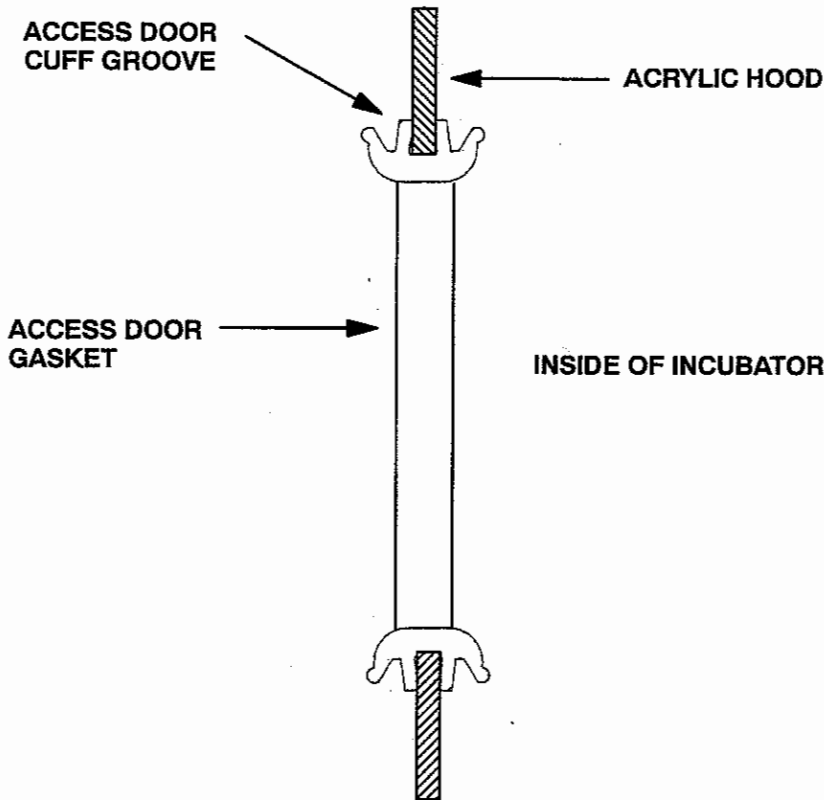

FIGURE 4.10 INSTALLATION OF ACCESS DOOR GASKET

- I. **INSTALL A NEW ACCESS DOOR CUFF** onto each Access Door Gasket by stretching the larger diameter elastic band into the groove in the gasket. When installed correctly, the cuff has a small opening at its center. The Access Door should latch with slight pressure and should open when the latch lever is depressed.

NOTE: If the Incubator is to be gas sterilized, wait until after sterilization to install new cuffs.

- J. **INSTALL HOOD INNER WALL** by reversing the procedure shown in Figure 4.2.
- K. **INSTALL THE HEAT SHIELD** onto the Access Panel.
- L. **INSTALL A NEW AIR INTAKE MICROFILTER** if necessary. Replace the Air Intake Microfilter Cover and tighten the two thumbscrews. If a new filter is installed, indicate the date on the place provided on the cover.
- M. **CHECK THAT THE INCUBATOR IS SECURELY CLAMPED TO STAND.** Locking bar should be approximately horizontal when locking bar is released and clamp is engaged in retainer on Incubator.

IMPORTANT: Perform a complete functional checkout (Paragraph 2.7.2 and 2.7.3) before returning the unit to service.

4.3 GAS STERILIZATION (DELETED)

Change 7

SECTION 5 SERVICE

5.1 GENERAL

This section provides Controller configuration procedures, calibration procedure, troubleshooting procedures and removal and replacement procedures.

5.2 THE DIAGNOSTIC MENU

The C500/550 Isolette® Infant Incubator Controller contains a Diagnostic Menu which has three sub-menus. The Configuration Menu, the Test System Menu and the System Information Menu. Figure 5.1 provides a diagram of the Diagnostic Menu structure.

THE CONFIGURATION MENU

This menu provides the users with the ability to change various operating parameters to suit their current needs. Refer to Section 2 for a description of these parameters along with a listing of the factory default settings.

THE SYSTEM INFORMATION MENU

This menu provides service personnel with data collection logs and configuration information. In addition, it provides the user and service personnel with the Controller Software Version.

THE TEST SYSTEM MENU

This menu is intended for use only by qualified service personnel and provides various test and calibration routines.

The Diagnostic Menu may be accessed by simultaneously pressing and holding the $> 37^{\circ}$ and $^{\circ}\text{C}/^{\circ}\text{F}$ keys when the message SELF-TEST RUNNING is appearing in the Controller Message Center. The Message Diagnostic Menu will appear for approximately 5 seconds, then go to the Configuration Sub-Menu.

The remaining sub-menus (Test System and System Information) can then be selected by using the **Air Set Temperature** or **Baby Set Temperature** (C550 only) up/down arrow keys.

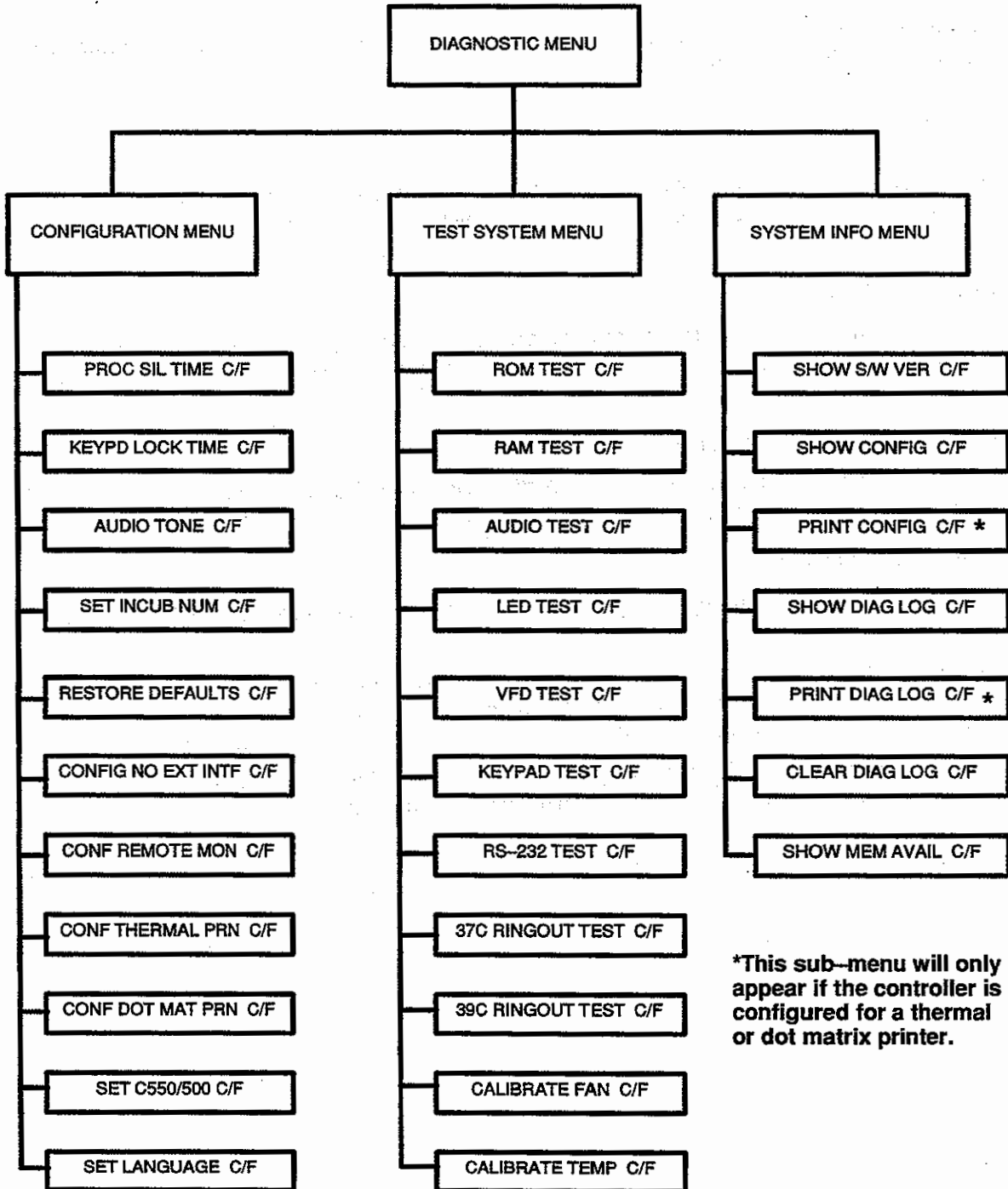

FIGURE 5.1 DIAGNOSTIC MENU STRUCTURE

5.3 THE CONFIGURATION MENU

Upon installation, or at any time during use, Incubator parameters (refer to Paragraph 2.6) may be changed to meet the current needs of the operator. This is accomplished by first selecting the Configuration Menu (refer to Paragraph 5.3.1), then selecting the desired parameter menu.

5.3.1 SELECTING THE CONFIGURATION MENU

The Configuration Menu may be selected when the SELF-TEST RUNNING Message is appearing in the Message Center.

Before attempting to enter the Configuration Menu or change a parameter, refer to Section 3, the Message Center, and Section 4, Operation, Paragraph 4.1, Controls and Indicators of the Operator's Manual.

SELECTING THE CONFIGURATION MENU

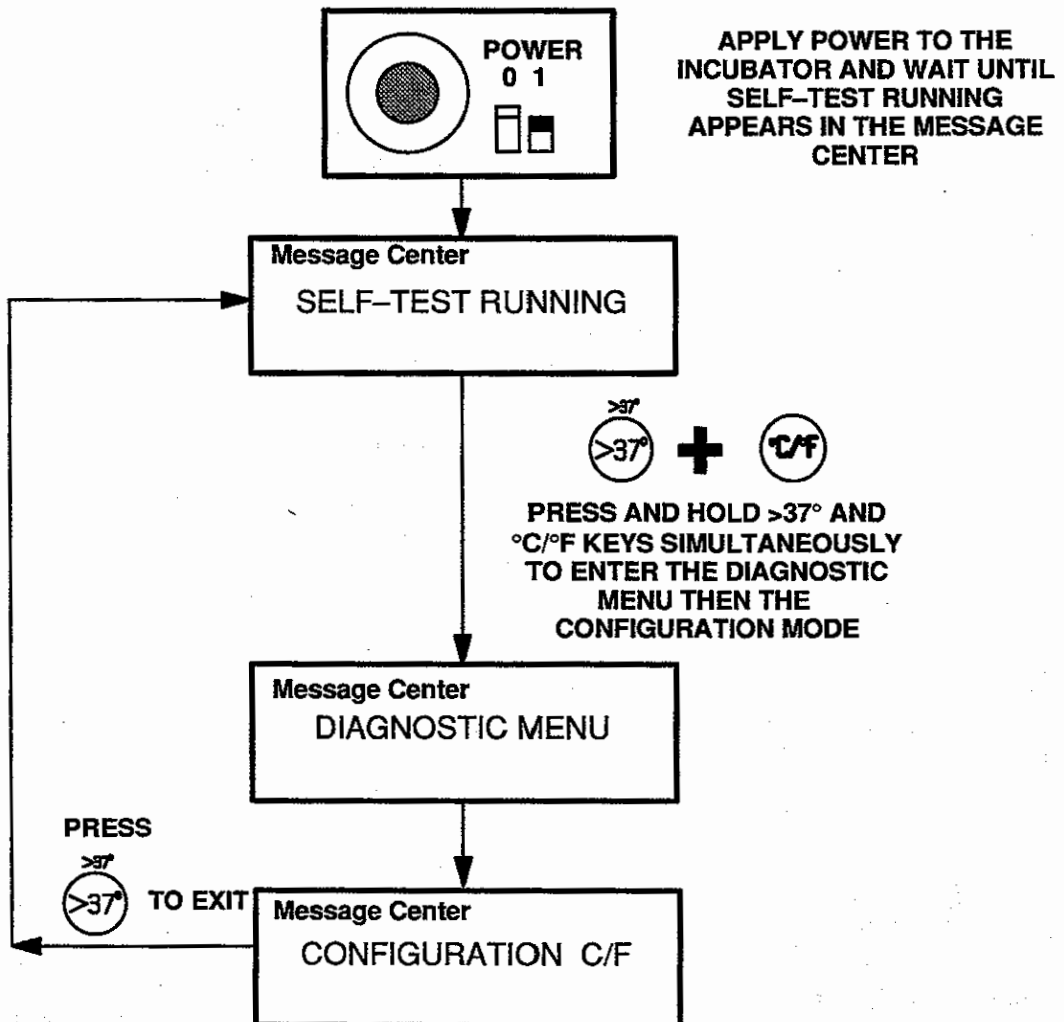

5.3.2 SETTING THE PROCEDURAL SILENCE TIME

The Procedural Silence Time duration may be set from 0 to 15 minutes. The default setting is 15 minutes. To set the Procedural Silence Time duration, first select the Configuration Menu (refer to Paragraph 5.3.1), then proceed as follows:

SETTING THE PROCEDURAL SILENCE TIME DURATION (Sheet 1)

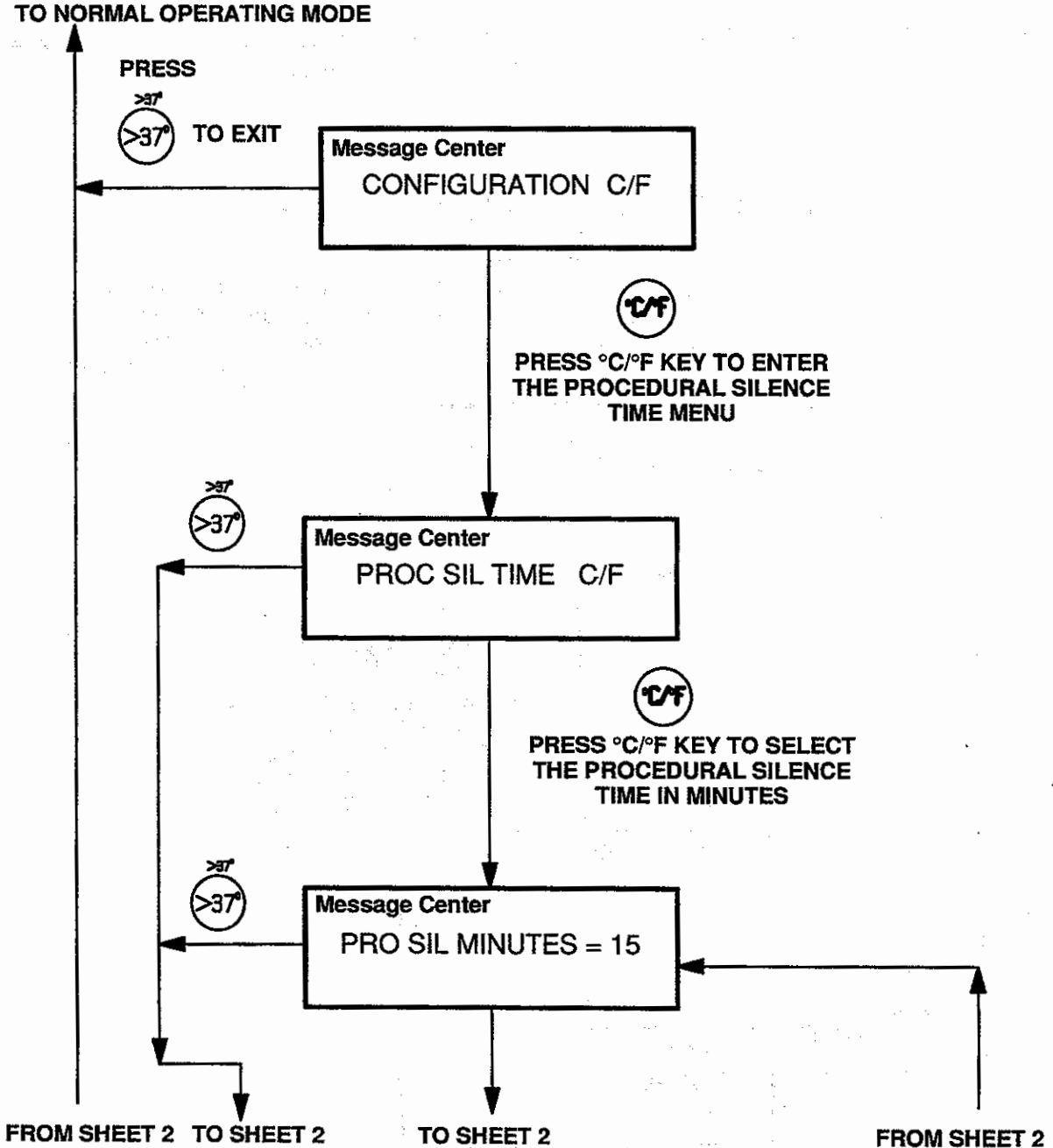

SETTING THE PROCEDURAL SILENCE TIME DURATION (Sheet 2)

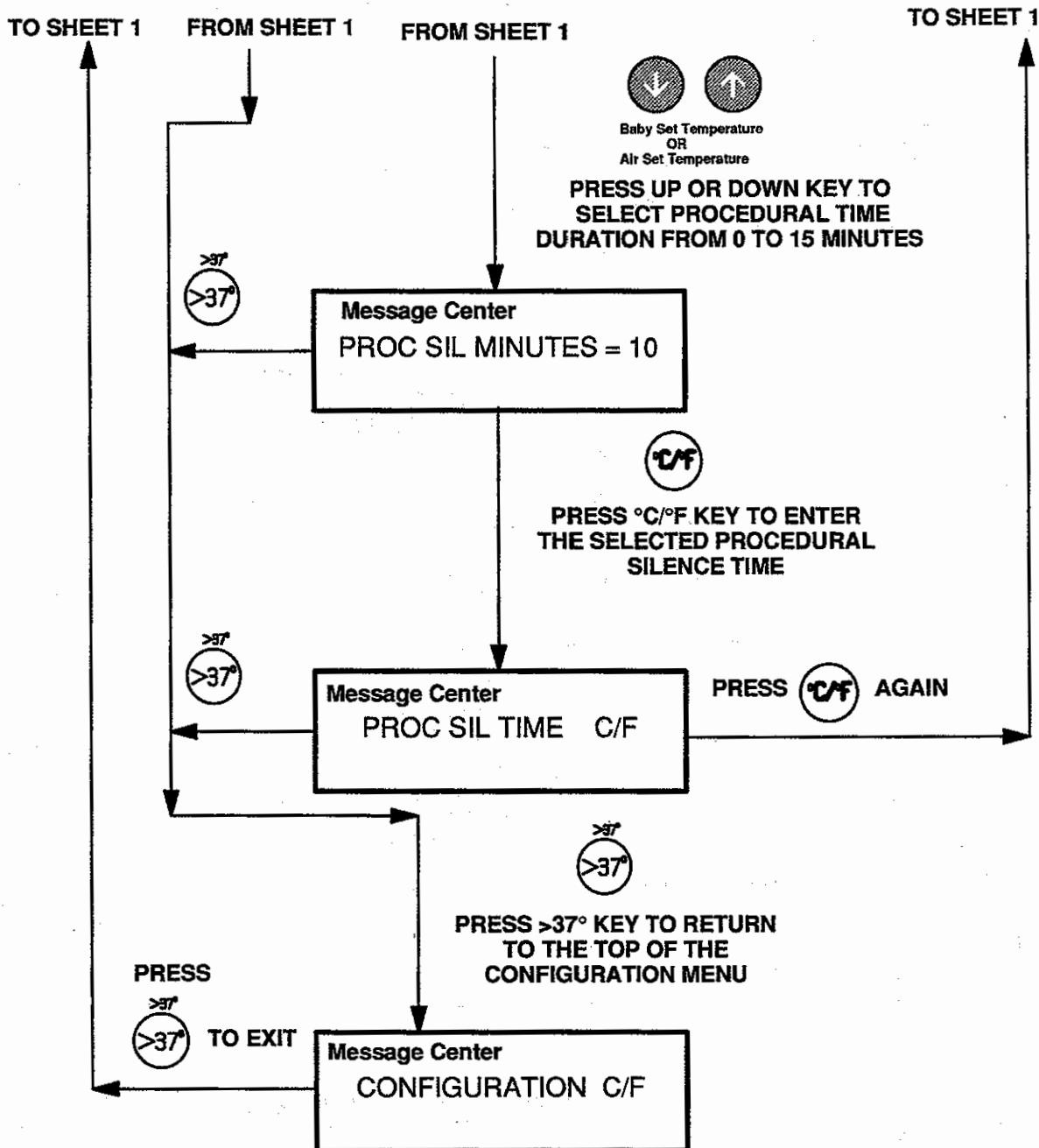

5.3.3 SETTING THE KEYPAD TIME-TO-LOCK TIME

The Keypad Time-to-Lock duration may be set from 0 to 10 minutes. To set the the Time-to-Lock duration, first select the Configuration Menu (refer to Paragraph 5.3.1), then proceed as follows:

SETTING THE KEYPAD LOCK TIME (Sheet 1)

TO NORMAL OPERATING MODE

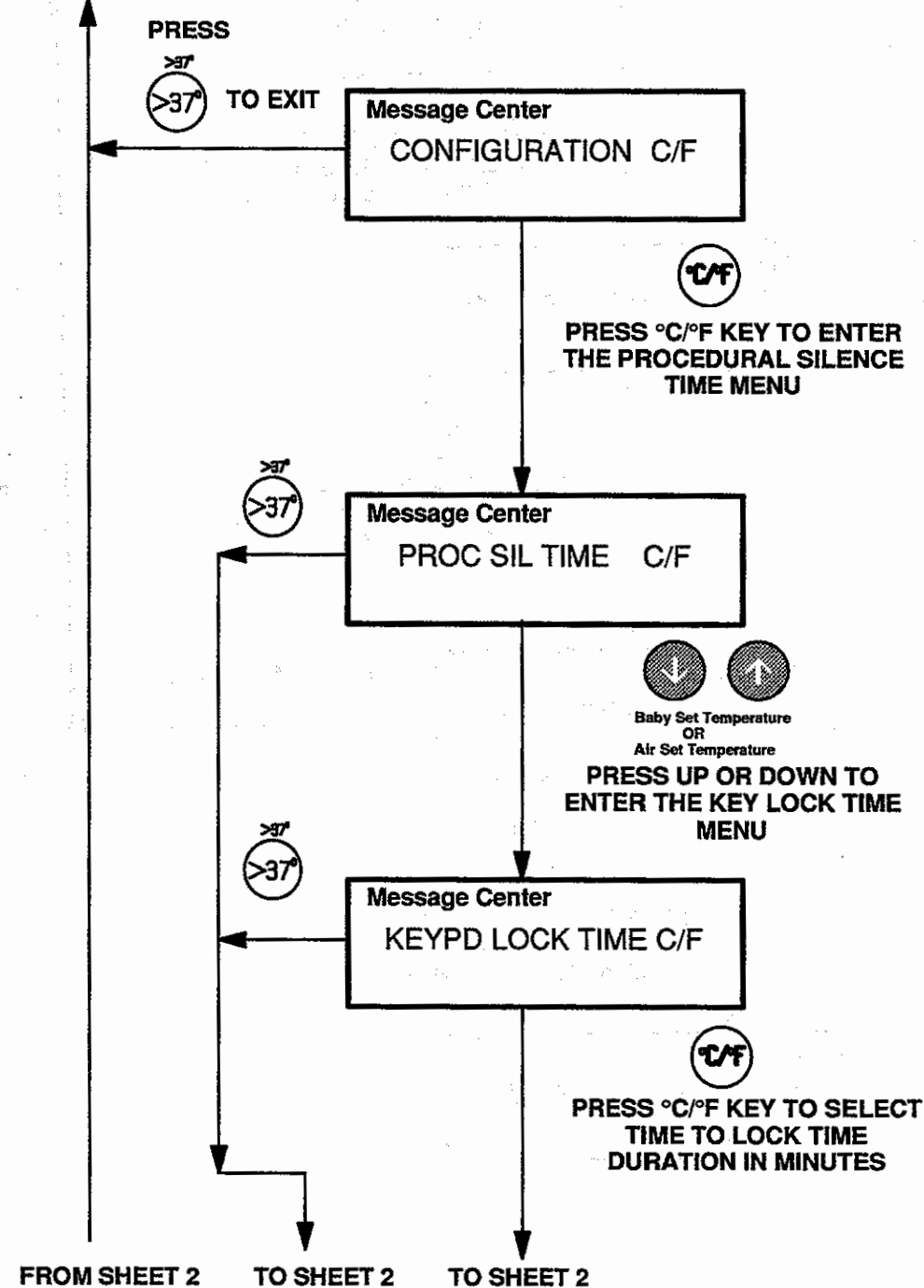

SETTING THE KEYPAD LOCK TIME (Sheet 2)

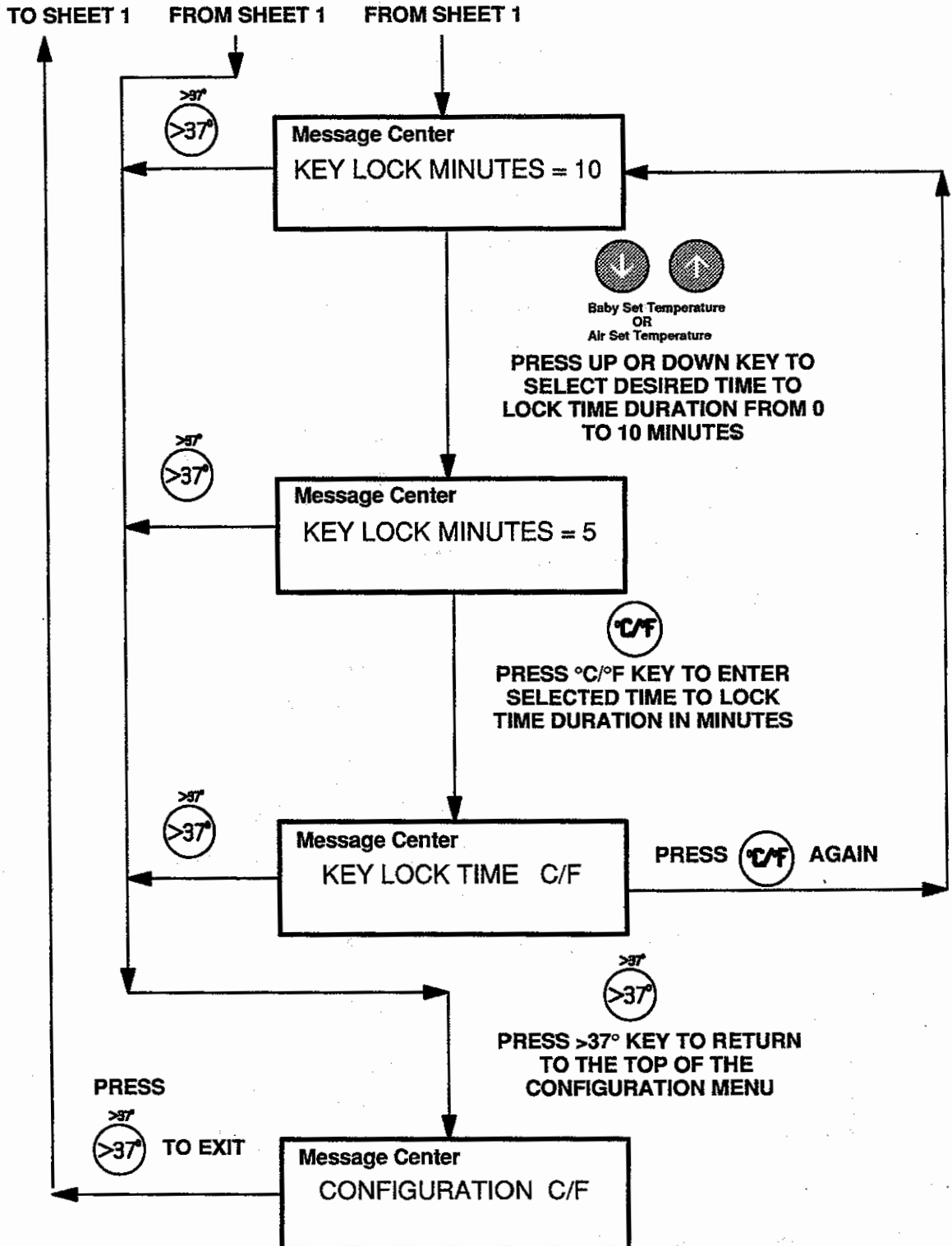

5.3.4 SELECTING AN AUDIO TONE

The Incubator has five different audio tones available. To select an alarm tone, first select the Configuration Menu (refer to Paragraph 5.3.1), then proceed as follows:

SELECTING AN AUDIO TONE (Sheet 1)

TO NORMAL OPERATING MODE

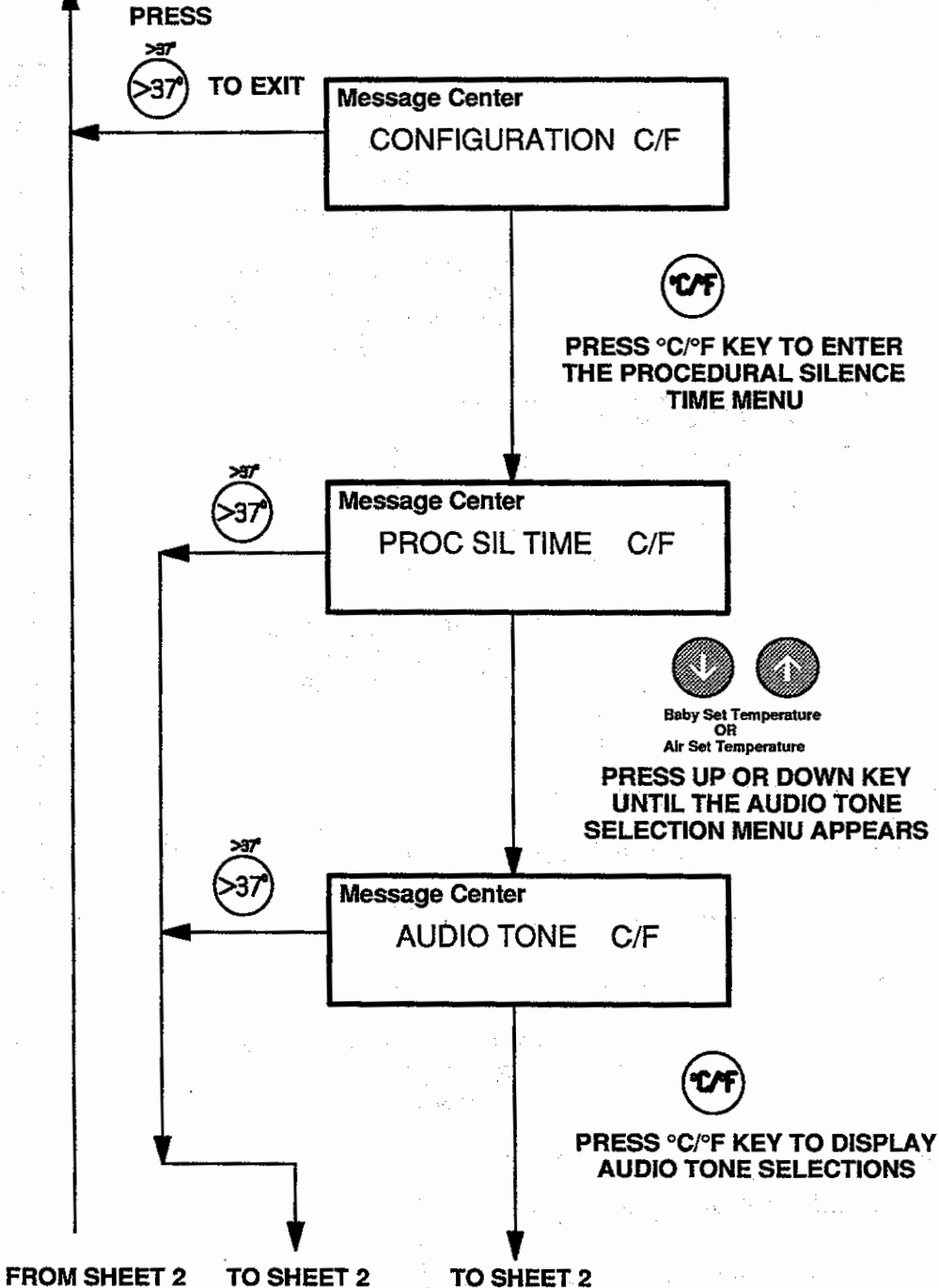

SELECTING AN AUDIO TONE (Sheet 2)

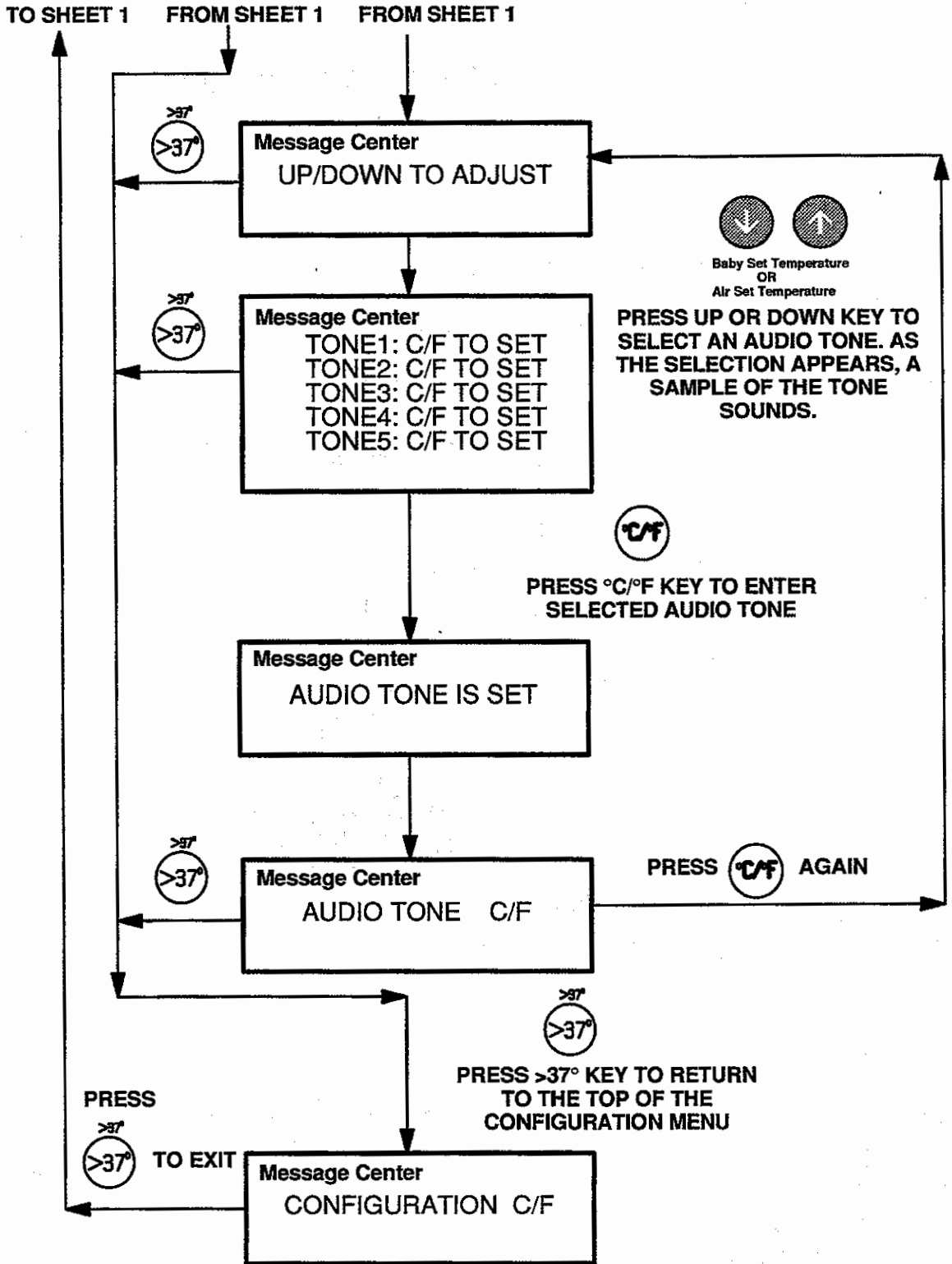

5.3.5 SELECTING AN INCUBATOR NUMBER

An Incubator Number from 01 to 99 may be selected. To select an Incubator Number, first select the Configuration Menu (refer to Paragraph 5.3.1), then proceed as follows:

SELECTING AN INCUBATOR NUMBER (Sheet 1)

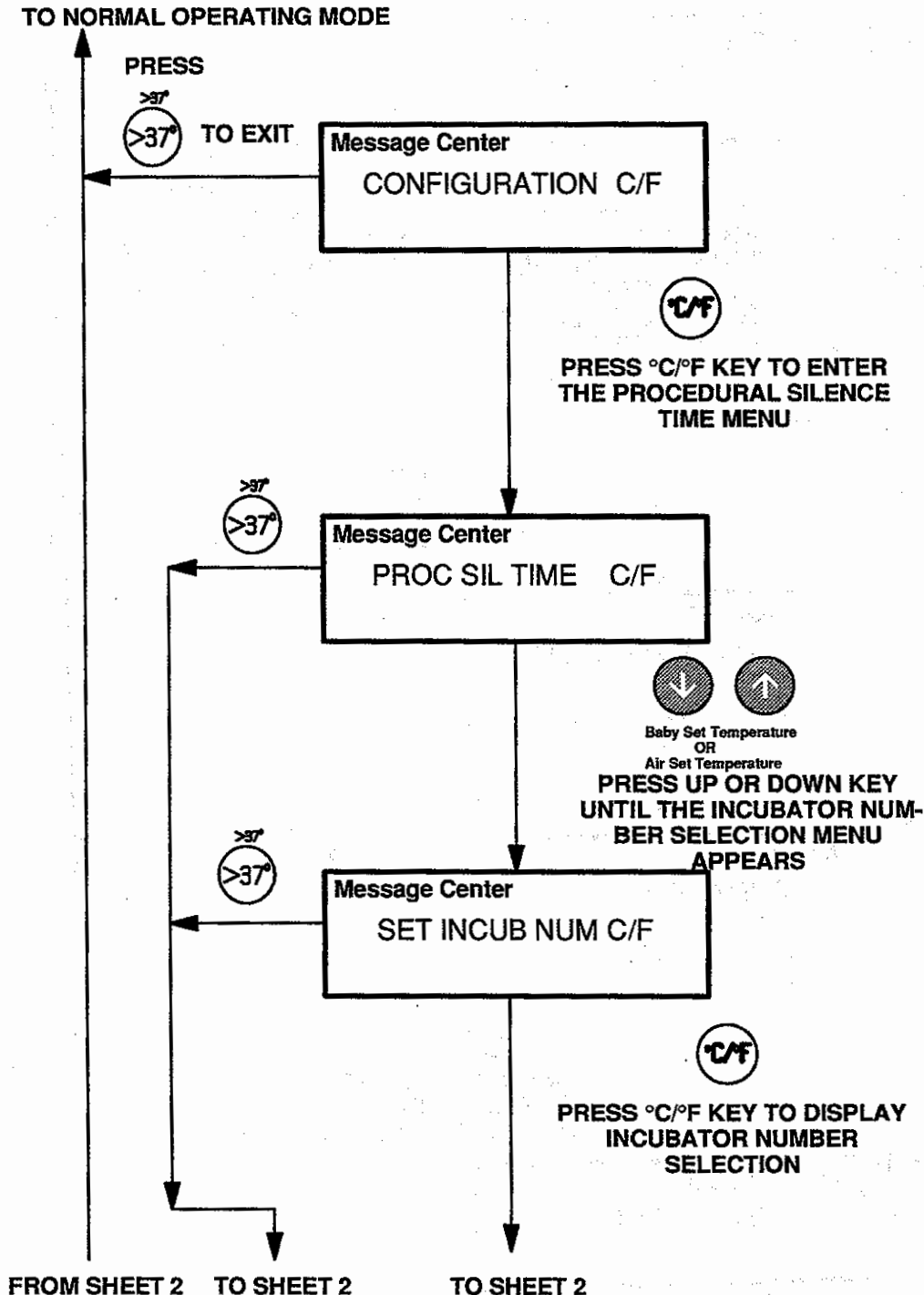

SELECTING AN INCUBATOR NUMBER

(Sheet 2)

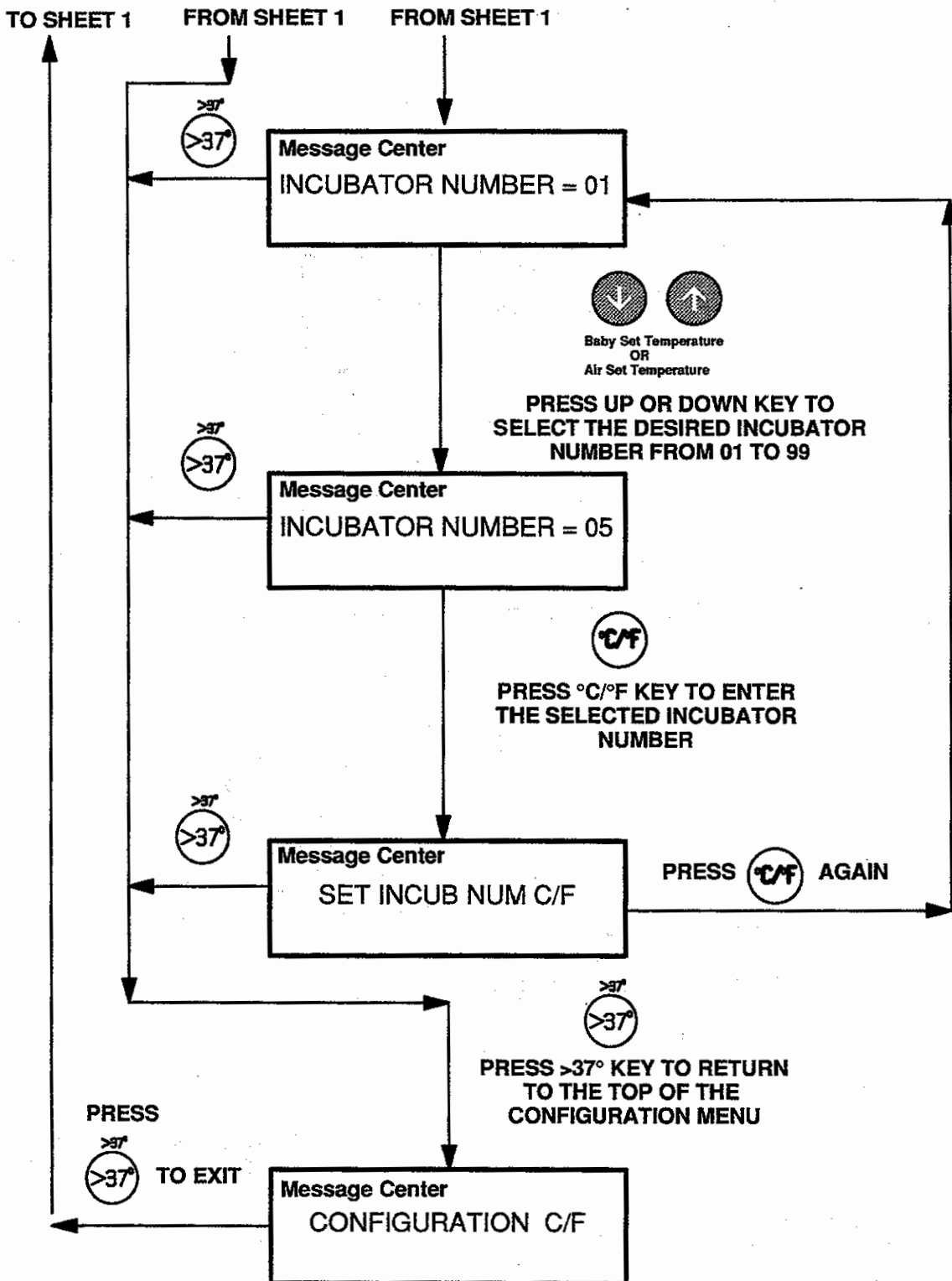

5.3.6 RESTORING FACTORY DEFAULT SETTINGS

To restore the factory default settings for Air Mode, Air and Baby Set Temperature, Procedural Silence Time, Keypad Time-to-Lock, Audio Tone, Incubator Number and No External Interface, first select the Configuration Menu (refer to Paragraph 5.3.1), then proceed as follows:

RESTORING FACTORY DEFAULTS (Sheet 1)

TO NORMAL OPERATING MODE

PRESS



Message Center
CONFIGURATION C/F



PRESS °C/°F KEY TO ENTER
THE PROCEDURAL SILENCE
TIME MENU



Message Center
PROC SIL TIME C/F



Baby Set Temperature
OR
Air Set Temperature

PRESS UP OR DOWN KEY
UNTIL THE RESTORE
DEFAULTS MENU APPEARS



Message Center
RESTORE DEFAULTS C/F



PRESS °C/°F KEY TO ENTER
TO RESTORE FACTORY
DEFAULT SETTINGS

FROM SHEET 2 TO SHEET 2

TO SHEET 2

RESTORING FACTORY DEFAULTS (Sheet 2)

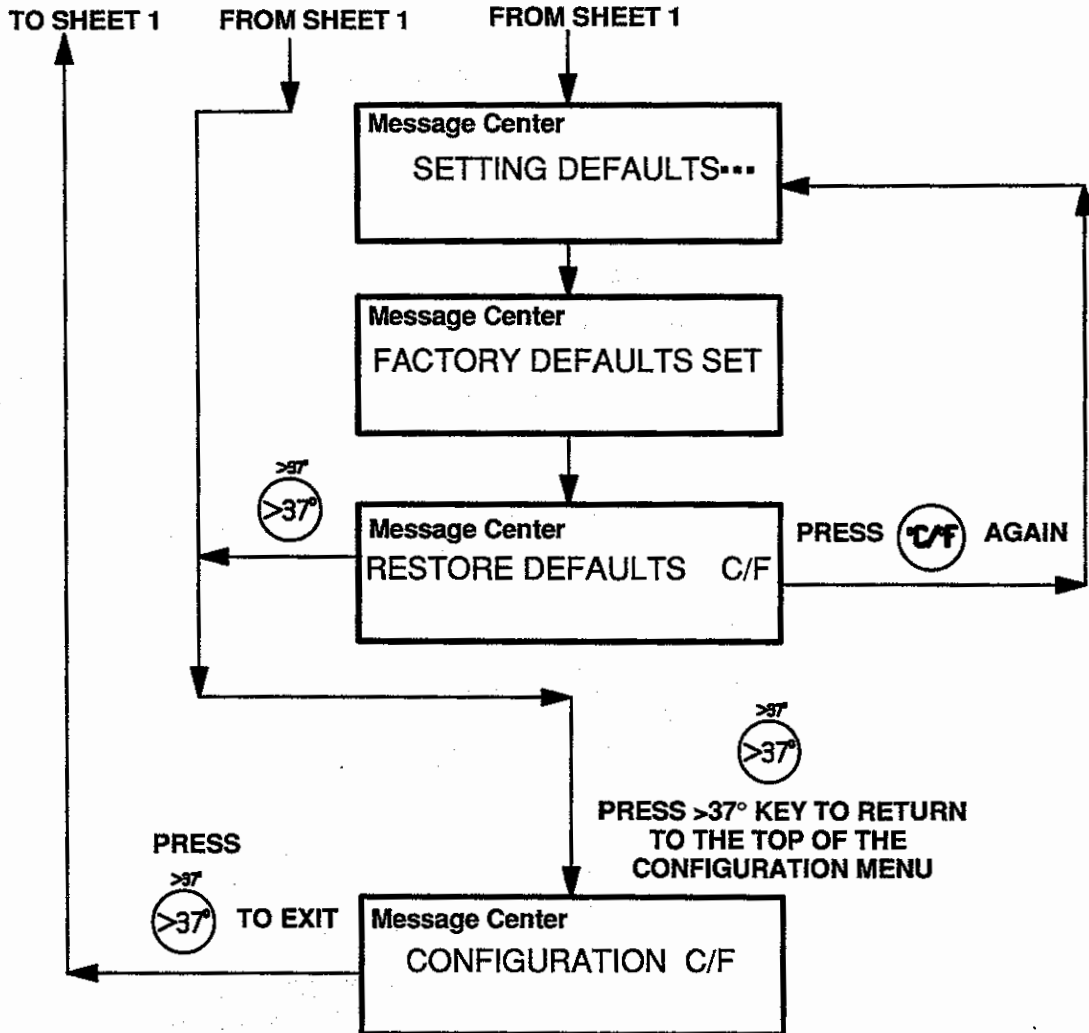

5.3.7 CONFIGURING THE CONTROLLER TO NO EXTERNAL INTERFACE

To disable the **SERIAL PORT** located on the Controller Side Panel, first select the Configuration Menu (refer to Paragraph 5.3.1), then proceed as follows:

NO EXTERNAL INTERFACE (Sheet 1)

TO NORMAL OPERATING MODE
PRESS



TO EXIT

Message Center
CONFIGURATION C/F



PRESS °C/°F KEY TO ENTER
THE PROCEDURAL SILENCE
TIME MENU



Message Center
PROC SIL TIME C/F



Baby Set Temperature
OR
Air Set Temperature

PRESS UP OR DOWN KEY
UNTIL THE NO EXTERNAL IN-
TERFACE MENU APPEARS



Message Center
CONF NO EXT INTF C/F



PRESS °C/°F KEY TO ENTER
TO DISABLE EXTERNAL
INTERFACE

FROM SHEET 2 TO SHEET 2

TO SHEET 2

NO EXTERNAL INTERFACE (Sheet 2)

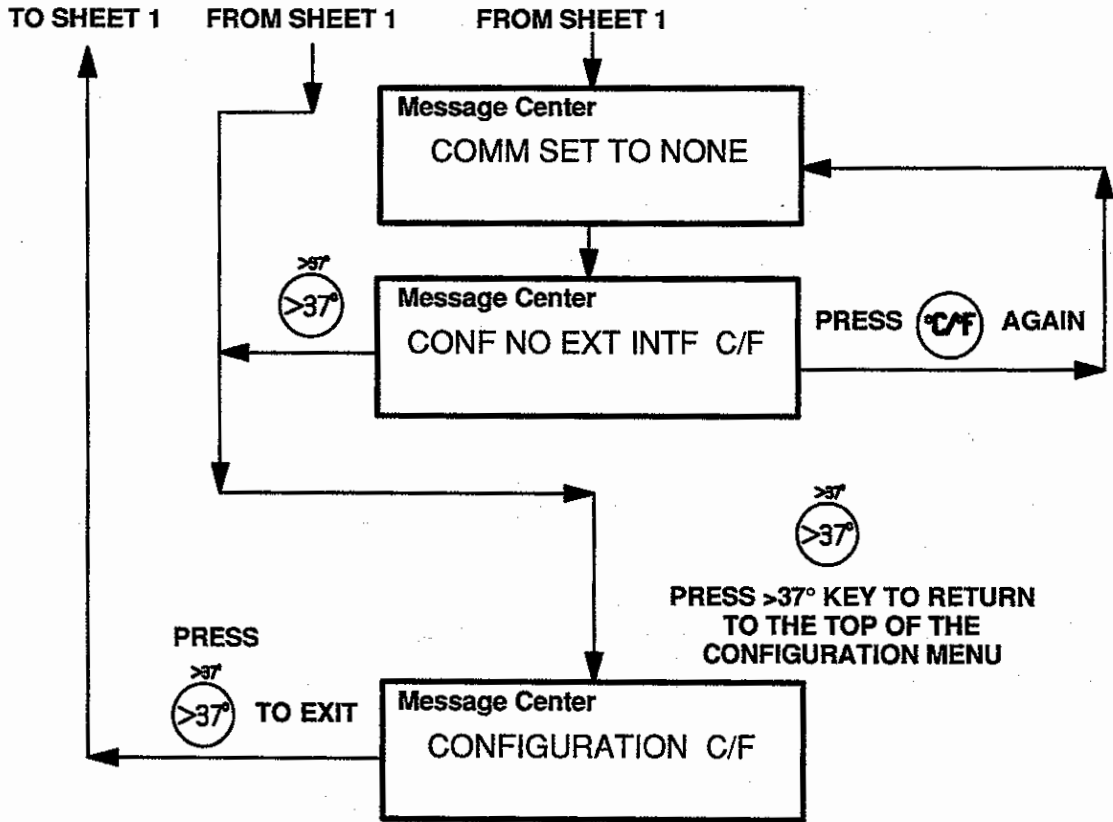

5.3.8 CONFIGURING THE CONTROLLER TO A REMOTE MONITOR

To configure the **SERIAL PORT** located on the Controller Side Panel to communicate with a remote monitor, first select the Configuration Menu (refer to Paragraph 5.3.1), then proceed as follows:

CONFIGURATION FOR A REMOTE MONITOR (Sheet 1)

TO NORMAL OPERATING MODE

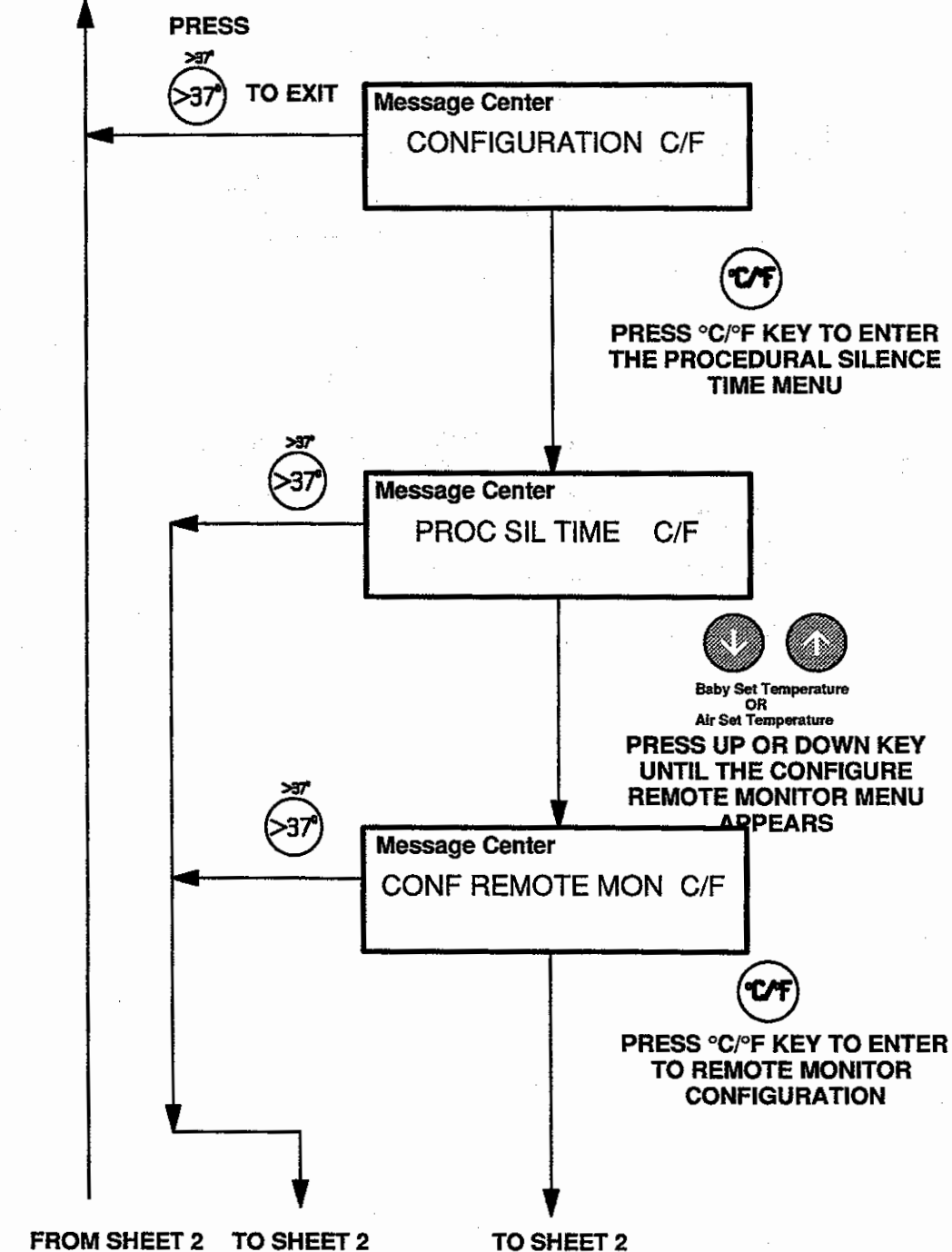

CONFIGURATION FOR A REMOTE MONITOR (Sheet 2)

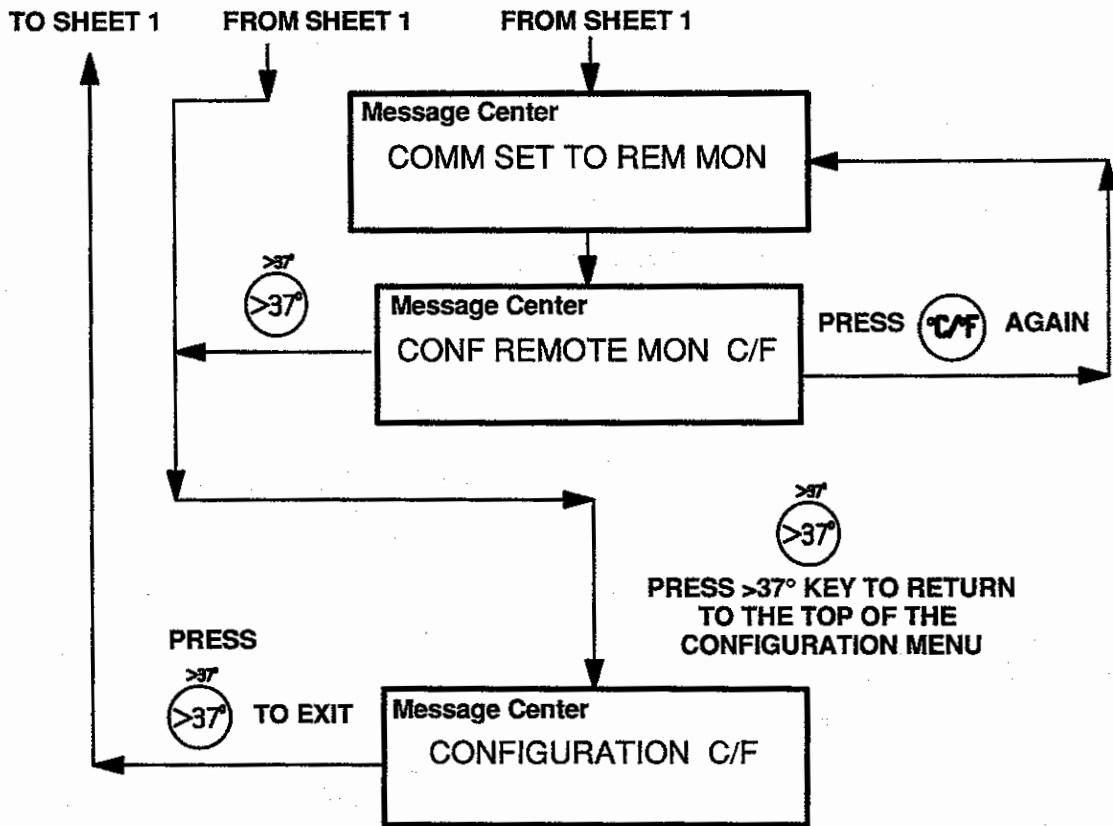

5.3.9 CONFIGURING THE CONTROLLER TO A THERMAL PRINTER

To configure the **SERIAL PORT** located on the Controller Side Panel to communicate with a thermal printer, first select the Configuration Menu (refer to Paragraph 5.3.1), then proceed as follows:

CONFIGURATION FOR A THERMAL PRINTER (Sheet 1)

TO NORMAL OPERATING MODE

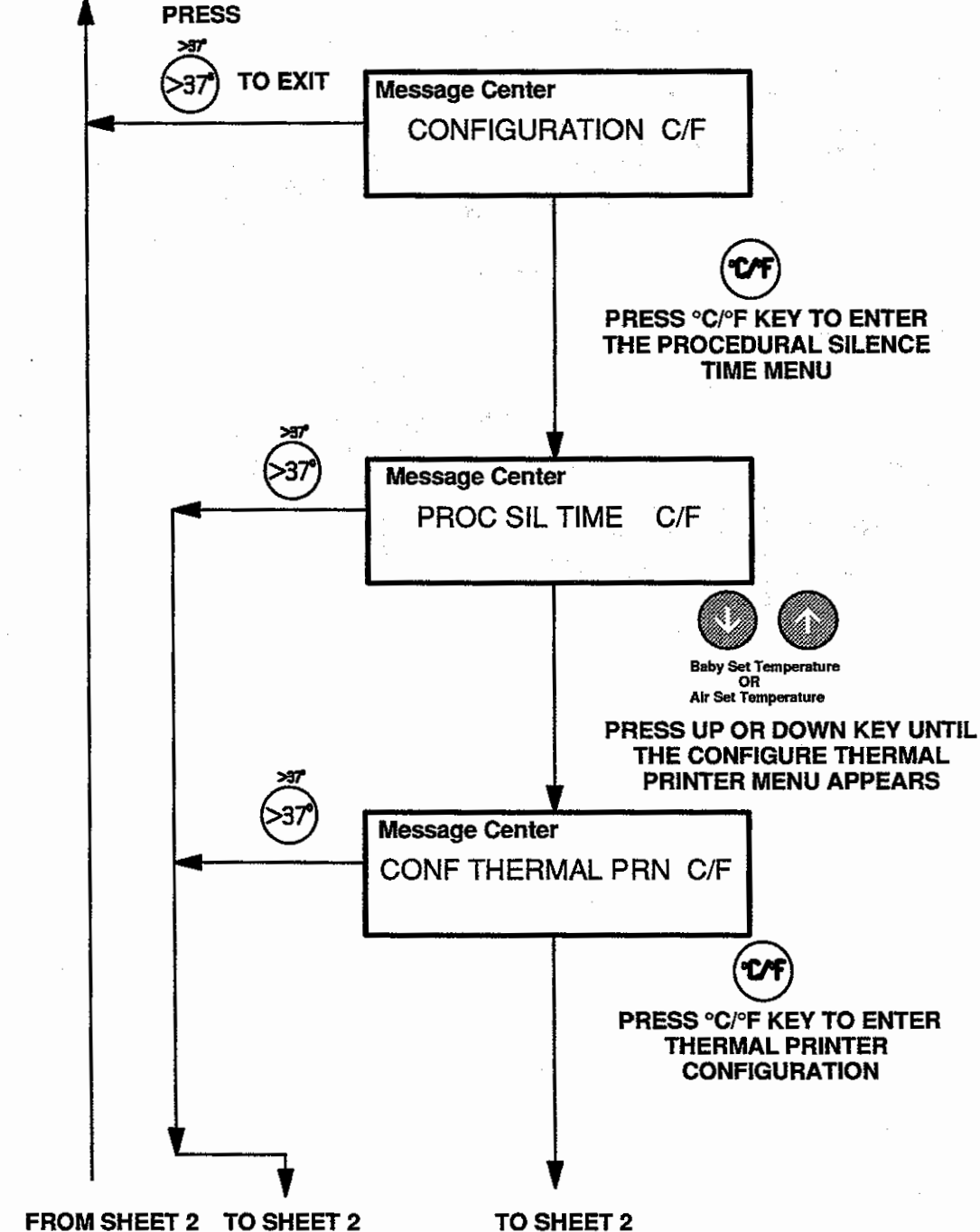

CONFIGURATION FOR A THERMAL PRINTER (Sheet 2)

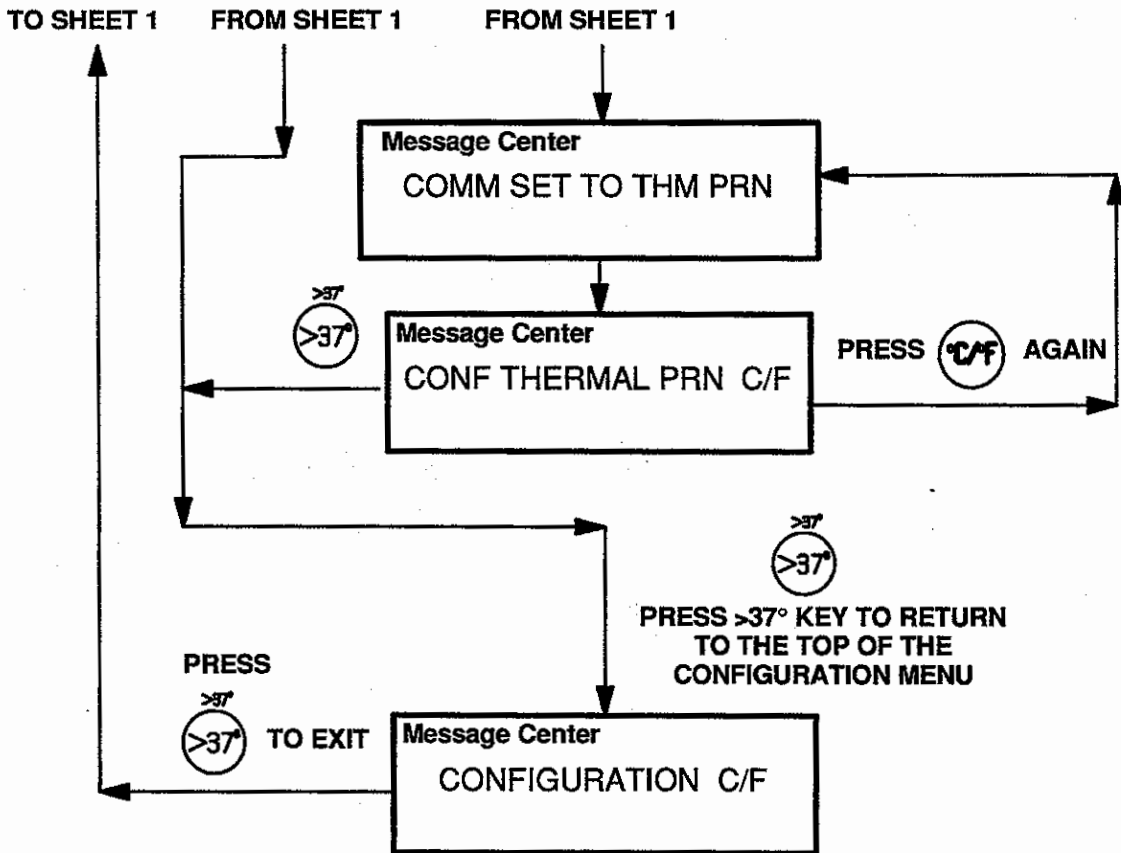

5.3.10 CONFIGURING THE CONTROLLER TO A DOT MATRIX PRINTER

To configure the **SERIAL PORT** located on the Controller Side Panel to communicate with a dot matrix printer, first select the Configuration Menu (refer to Paragraph 5.3.1), then proceed as follows:

CONFIGURATION FOR A DOT MATRIX PRINTER (Sheet 1)

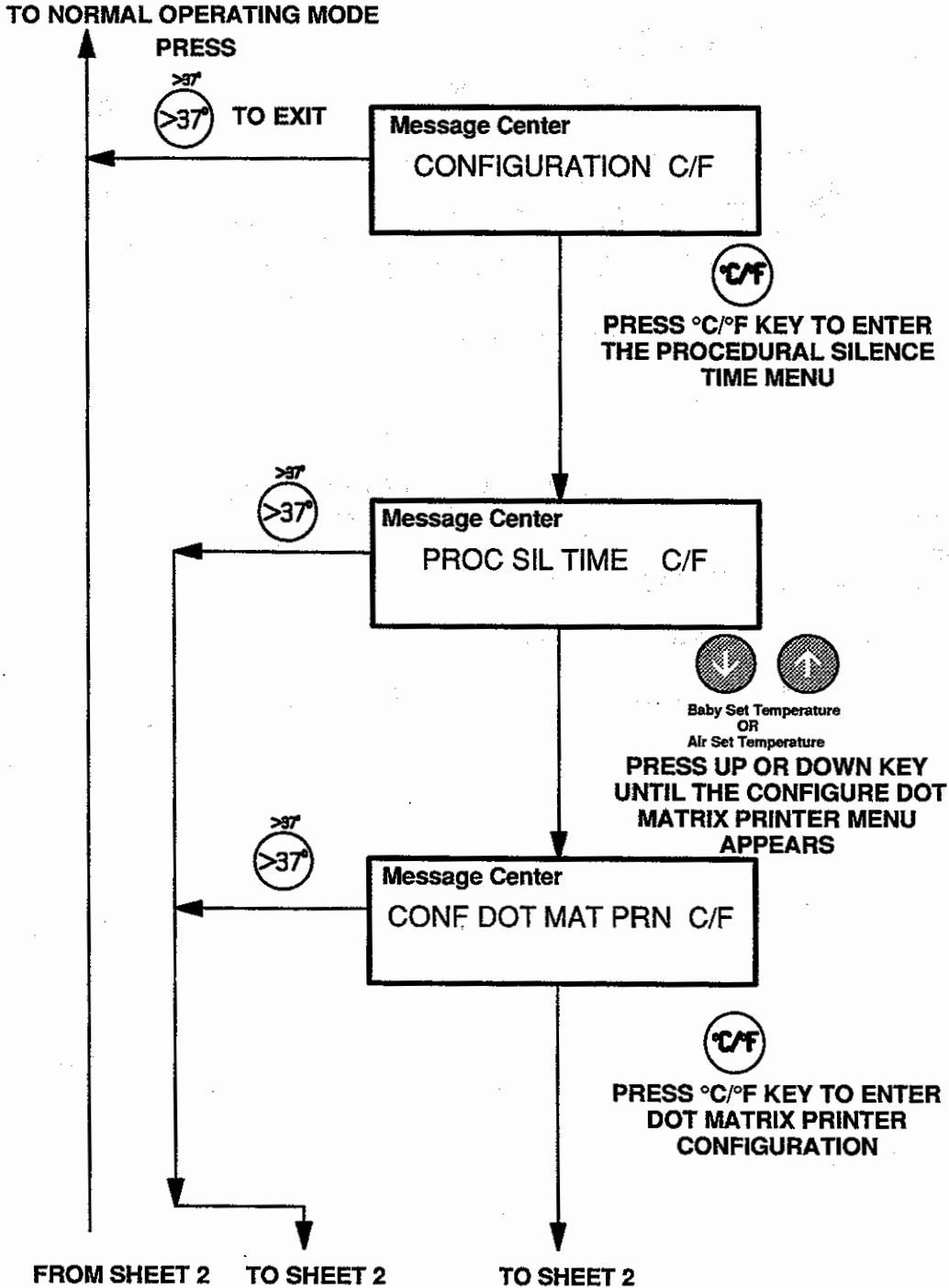

CONFIGURATION FOR A DOT MATRIX PRINTER (Sheet 2)

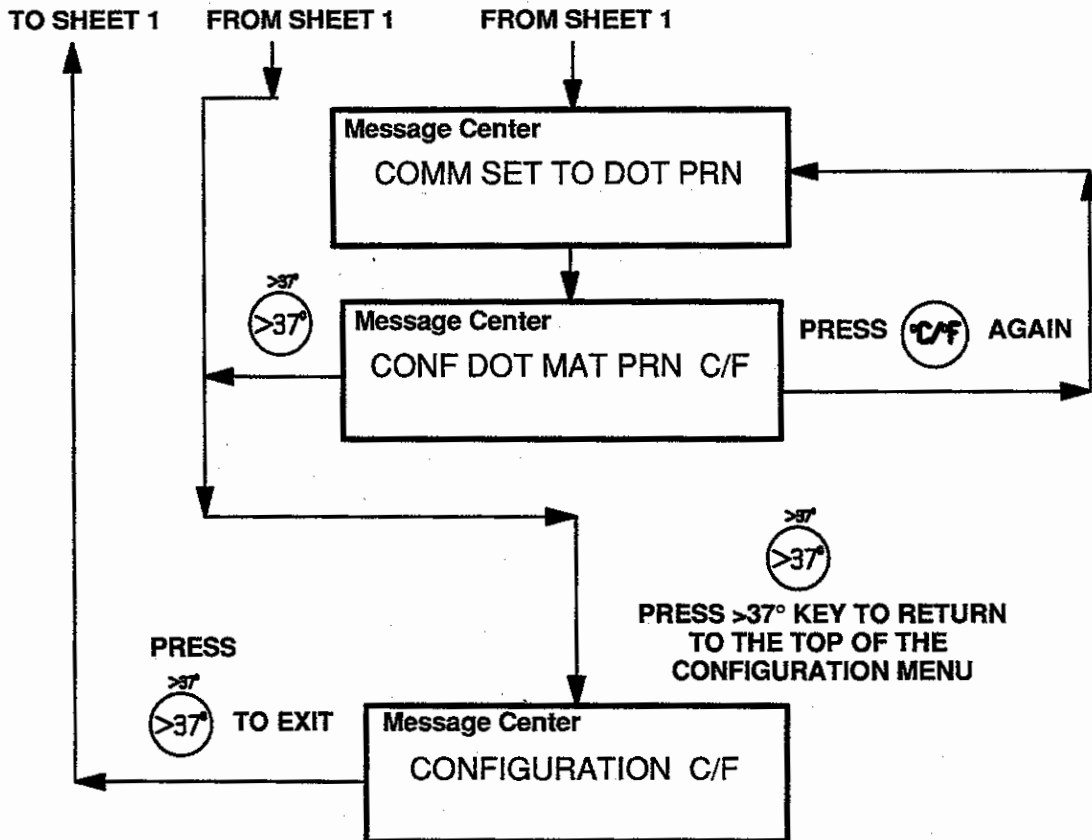

5.3.11 CHANGING THE CONTROLLER CONFIGURATION (C550 CONTROLLERS ONLY)

To disable the BABY MODE function of the C550 Controller, first select the Configuration Menu (refer to paragraph 5.3.1), then proceed as follows:

DISABLING THE BABY MODE FUNCTION (Sheet 1)

TO NORMAL OPERATING MODE

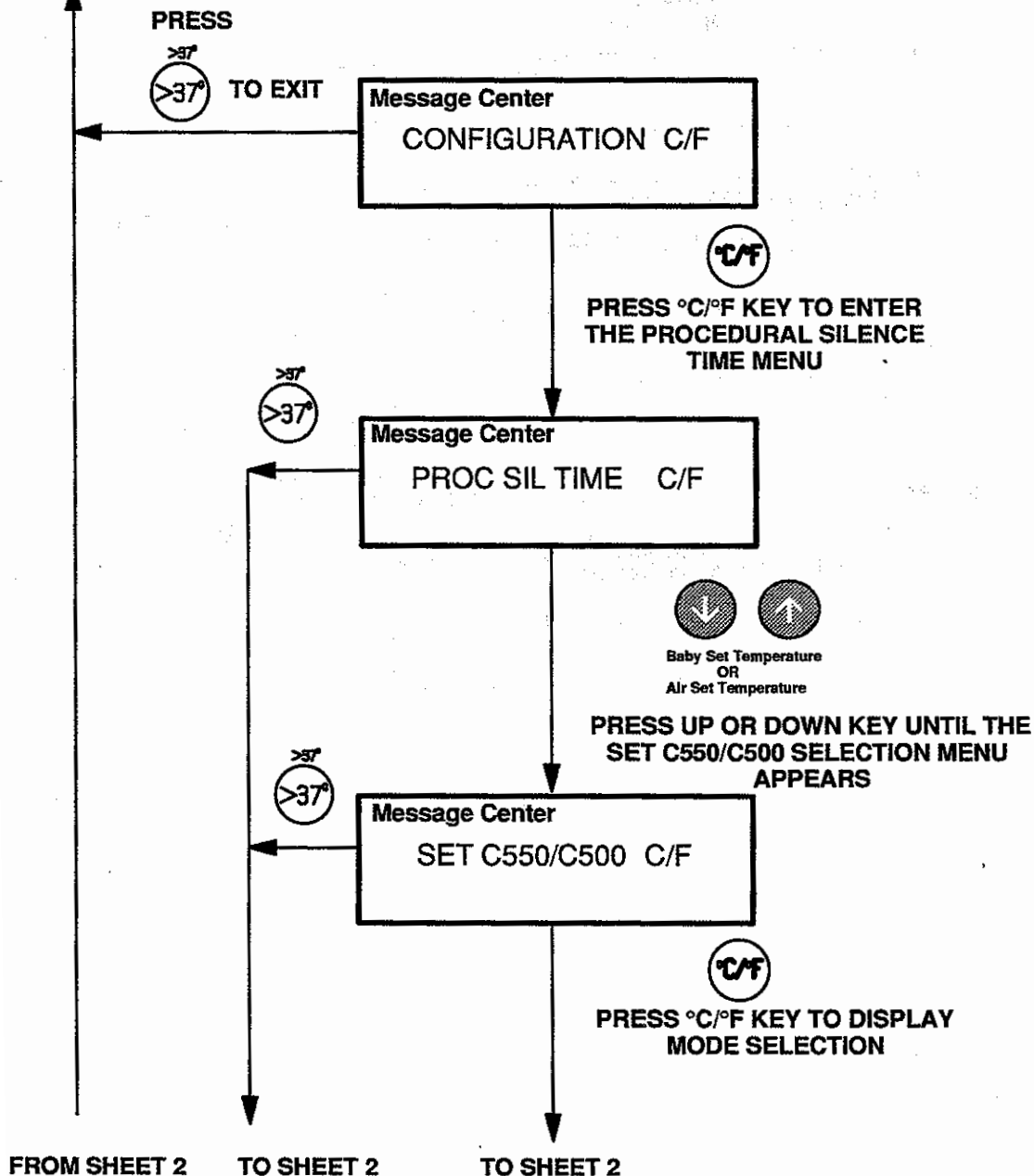

DISABLING THE BABY MODE FUNCTION (Sheet 2)

TO SHEET 1 FROM SHEET 1

FROM SHEET 1

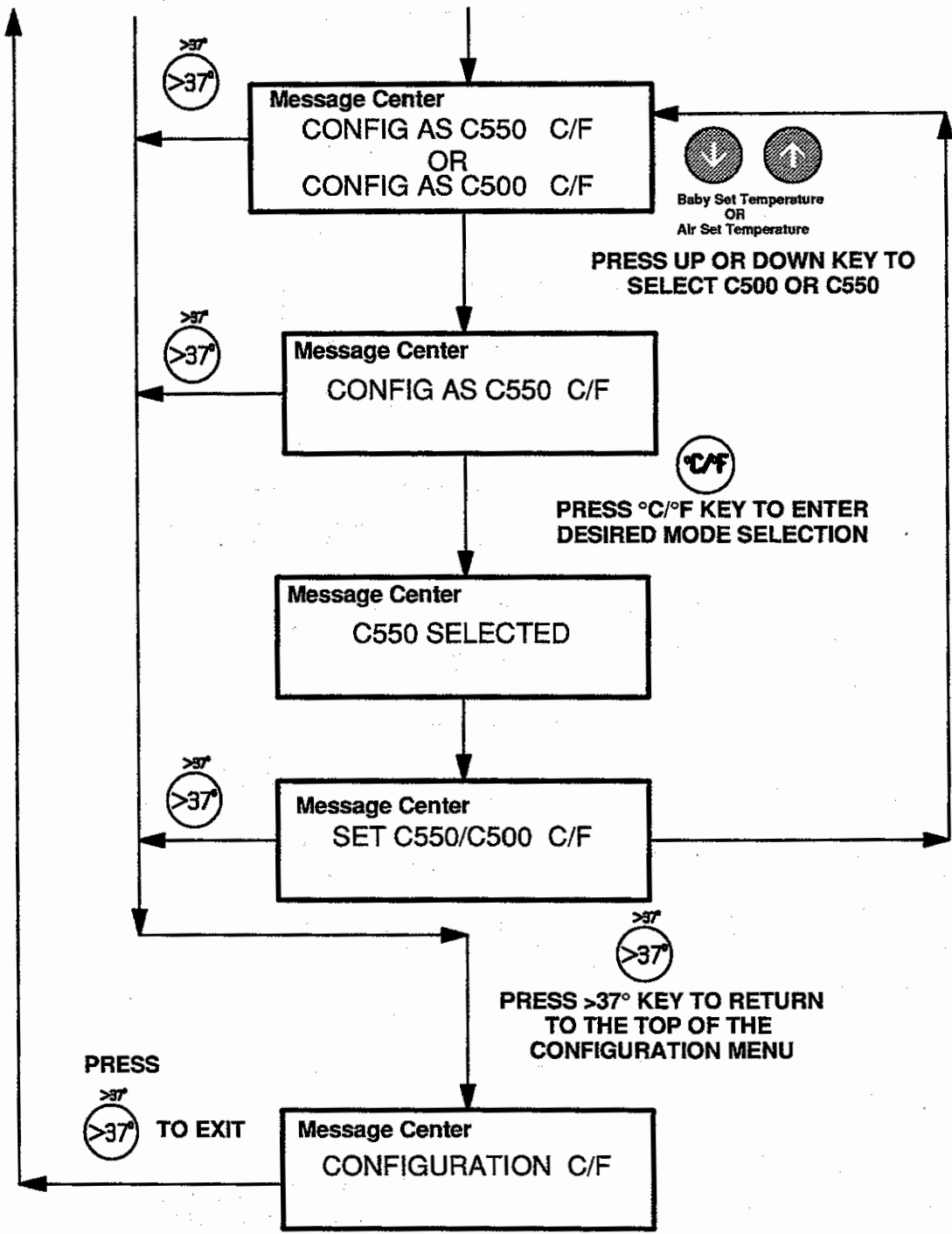

5.3.12 SELECTING A CONTROLLER MESSAGE CENTER LANGUAGE

The Controller Message Center has the capability to present messages in several different languages. These languages include English, French, Spanish, Italian, German and Russian. Alternately, Japanese may be substituted for German and Russian. To select a language, first select the Configuration Menu (refer to Paragraph 5.3.1), then proceed as follows:

SELECTING A LANGUAGE (Sheet 1)

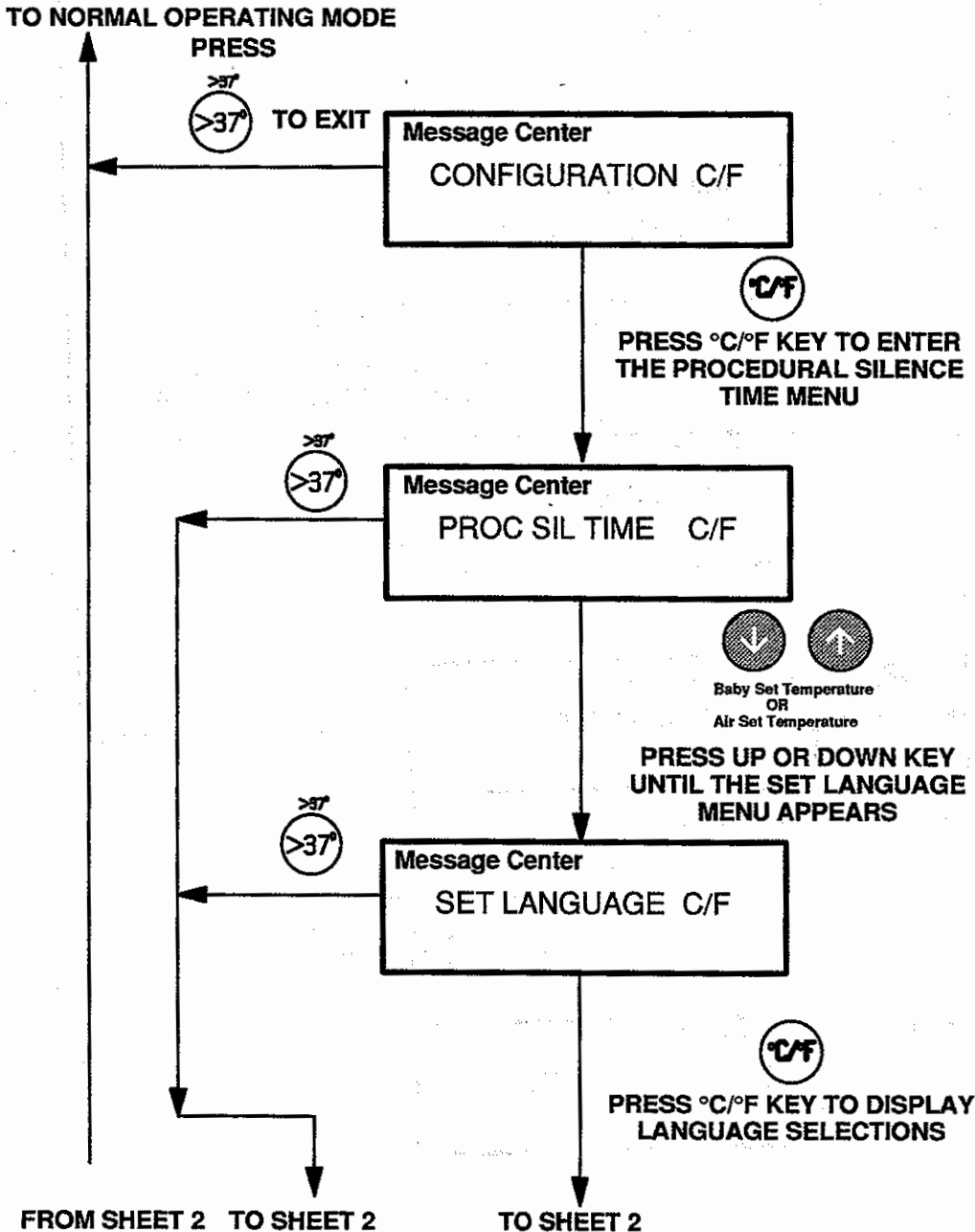

SELECTING A LANGUAGE (Sheet 2)

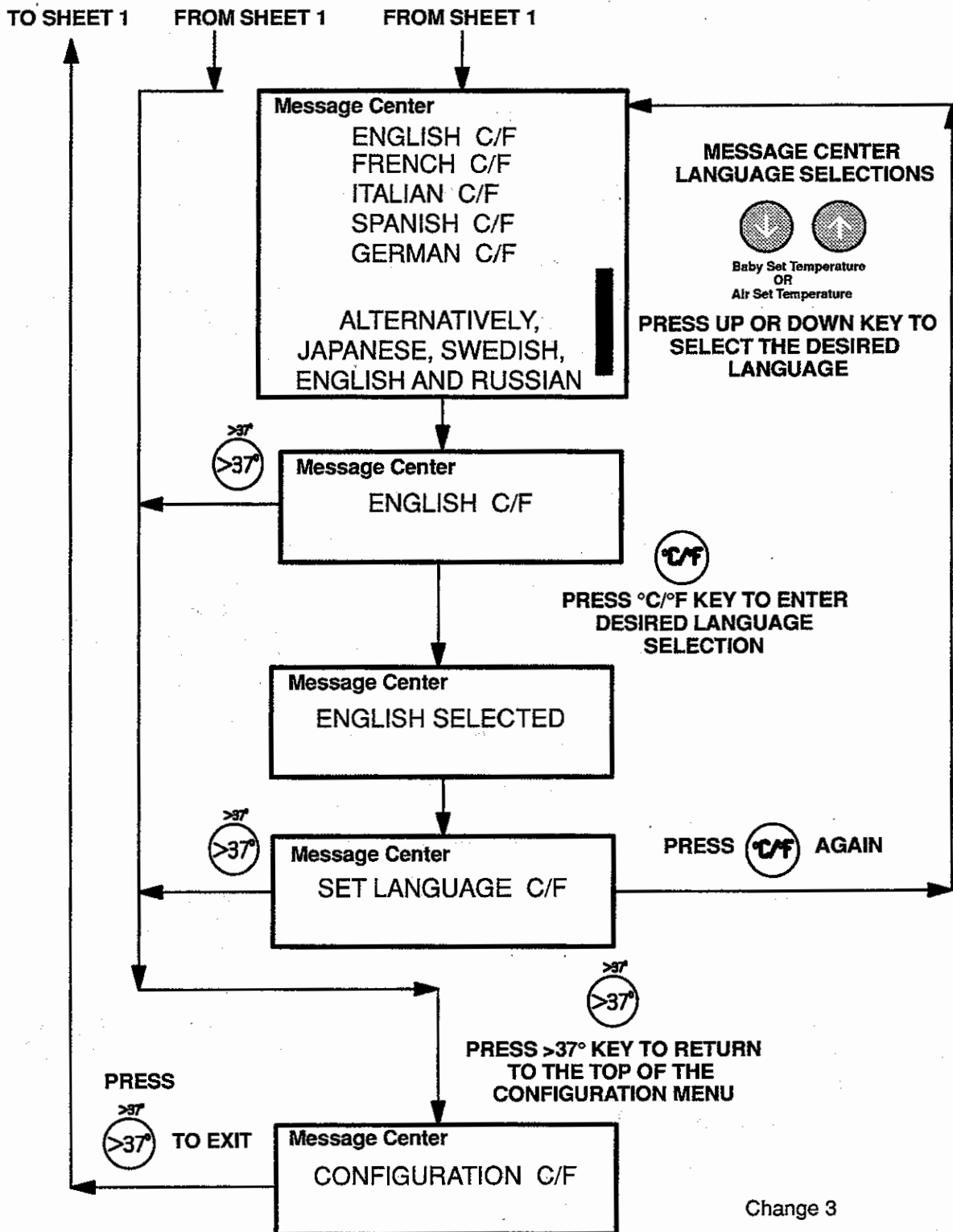

5.4 C500/C550 CONTROLLER SYSTEM INFORMATION MENU

5.4.1 SELECTING THE SYSTEM INFORMATION MENU

The System Information Menu may be selected when the SELF-TEST RUNNING Message is appearing in the Message Center.

Before attempting to enter the System Information Menu, refer to Section 3, The Message Center, and Section 4, Operation, Paragraph 4.1, Controls and Indicators of the Operator's Manual.

SELECTING THE SYSTEM INFORMATION MENU

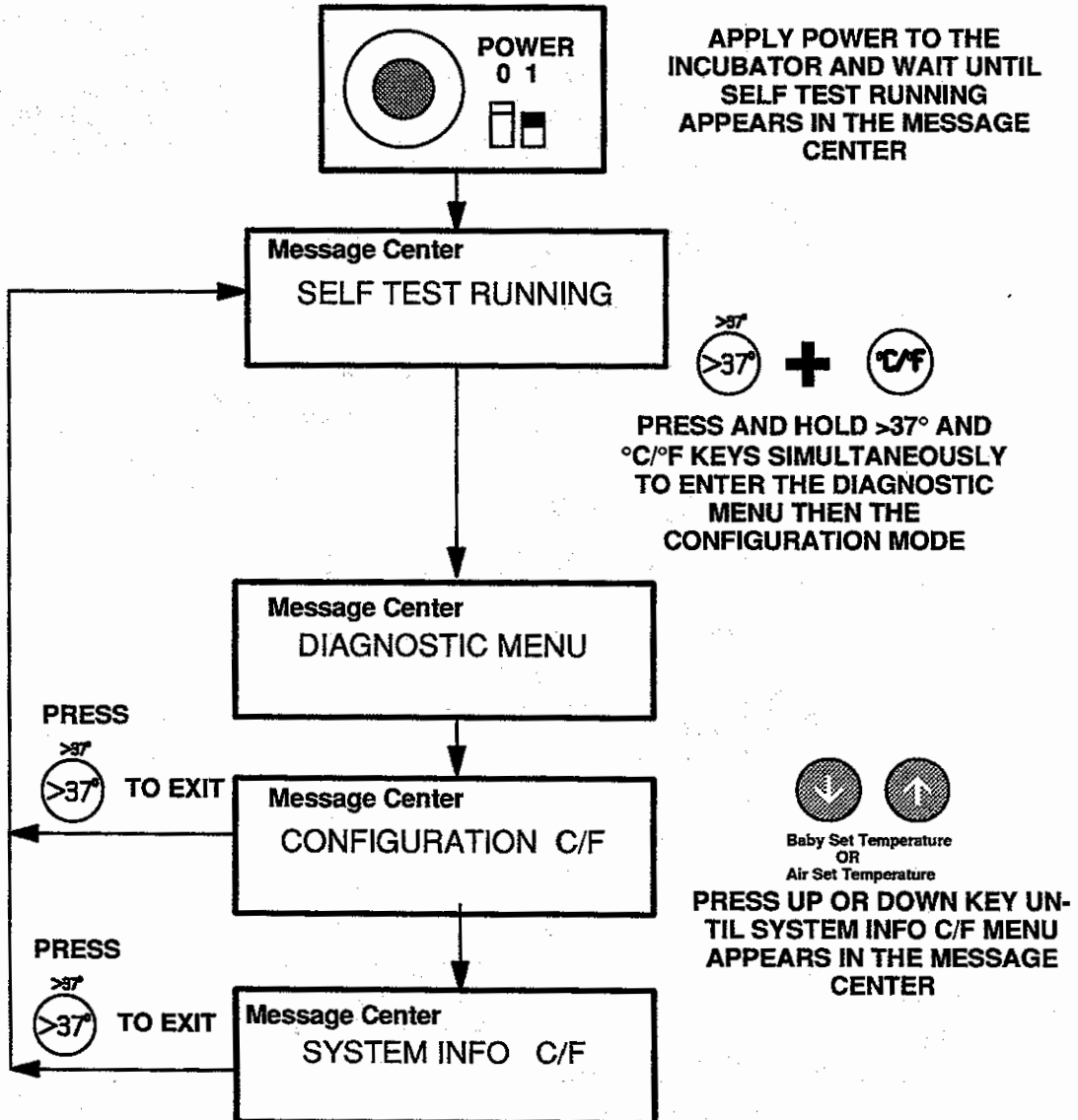

5.4.2 ACCESSING THE CONTROLLER SOFTWARE VERSION NUMBER

So that our service department may serve you better, please have the Controller Software Version number available when inquiring about operation or technical information. To access the System Software Version Number, first select the System Information Menu (refer to Paragraph 5.4.1), then proceed as follows:

ACCESSING THE CONTROLLER SOFTWARE VERSION NUMBER (Sheet 1)

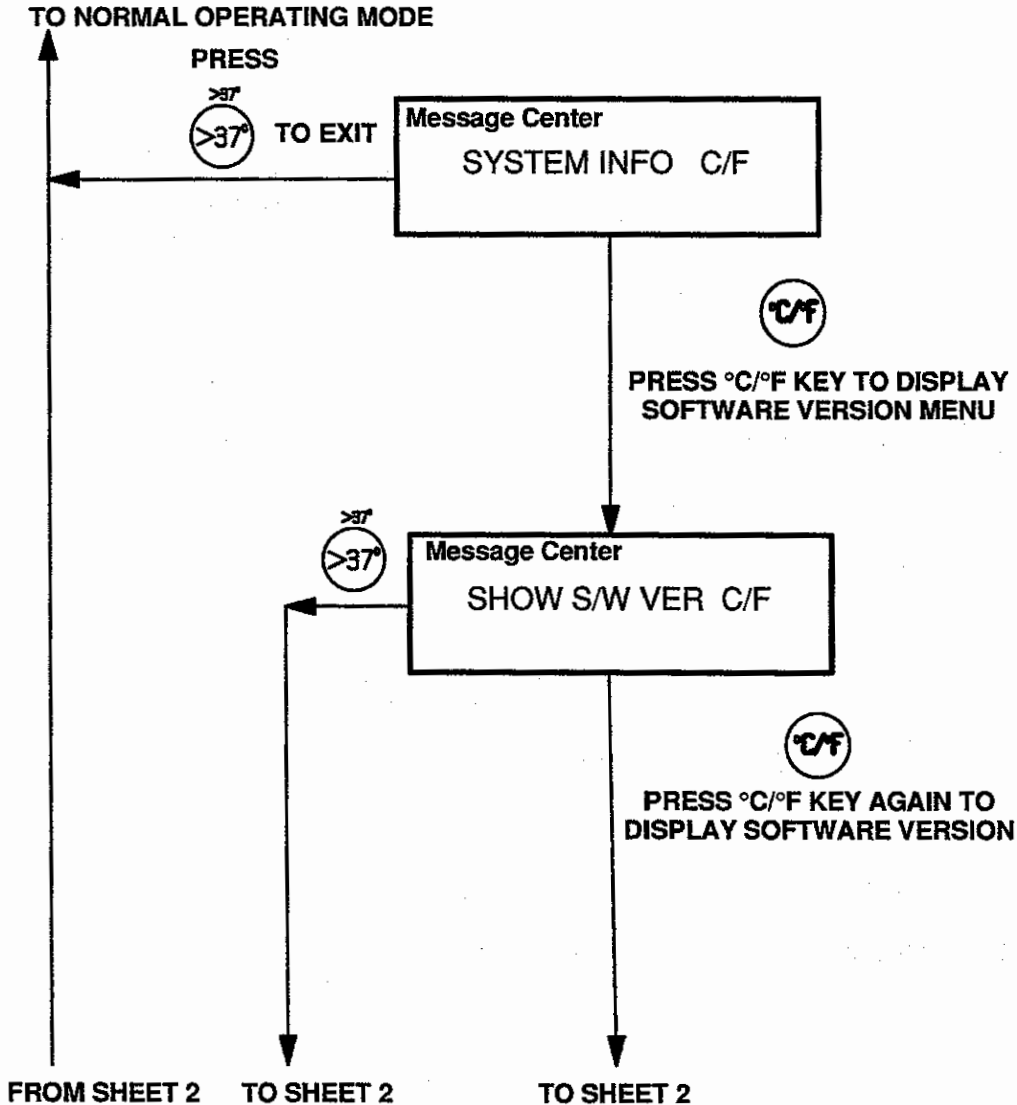

ACCESSING THE CONTROLLER SOFTWARE VERSION NUMBER (Sheet 2)

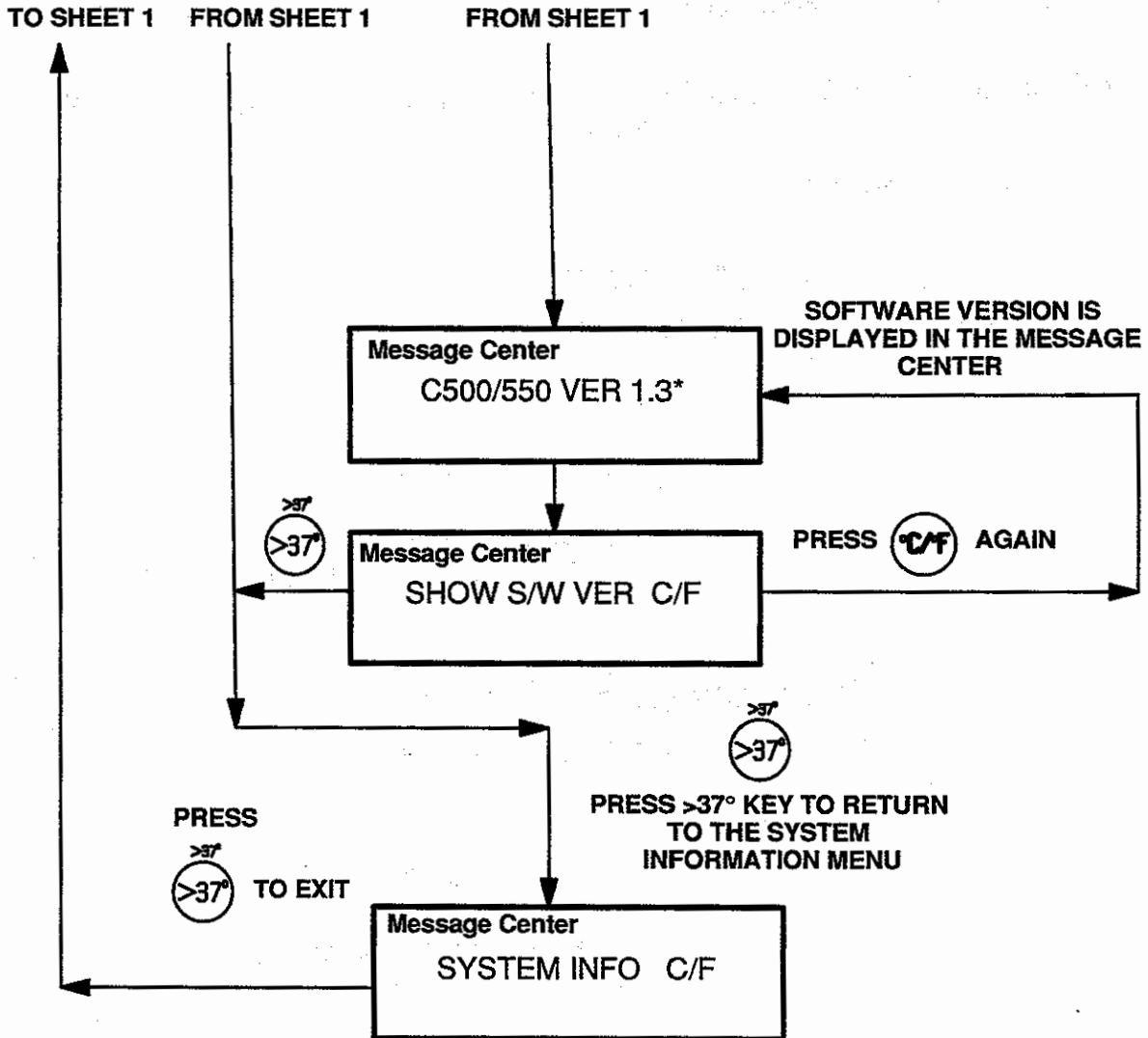

***NOTE: THE SOFTWARE VERSION OF YOUR CONTROLLER MAY DIFFER.**

5.4.3 ACCESSING THE CONTROLLER SHOW CONFIGURATION MENU

The Controller Show Configuration Menu will display all the Configurable Incubator Parameters and what they are currently set to. Refer to Section 2, Paragraph 2.6 for a complete explanation of these parameters and Paragraph 5.3 for procedures to change their settings. To access the the Show Configuration Menu, first select the System Information Menu (refer to Paragraph 5.4.1), then proceed as follows:

NOTE: This flowchart lists the Configurable Parameters along with their factory default setting. If it desired to obtain a print out of these parameters, refer to Paragraph 5.4.4 below.

ACCESSING THE CONTROLLER SHOW CONFIG MENU (Sheet 1)

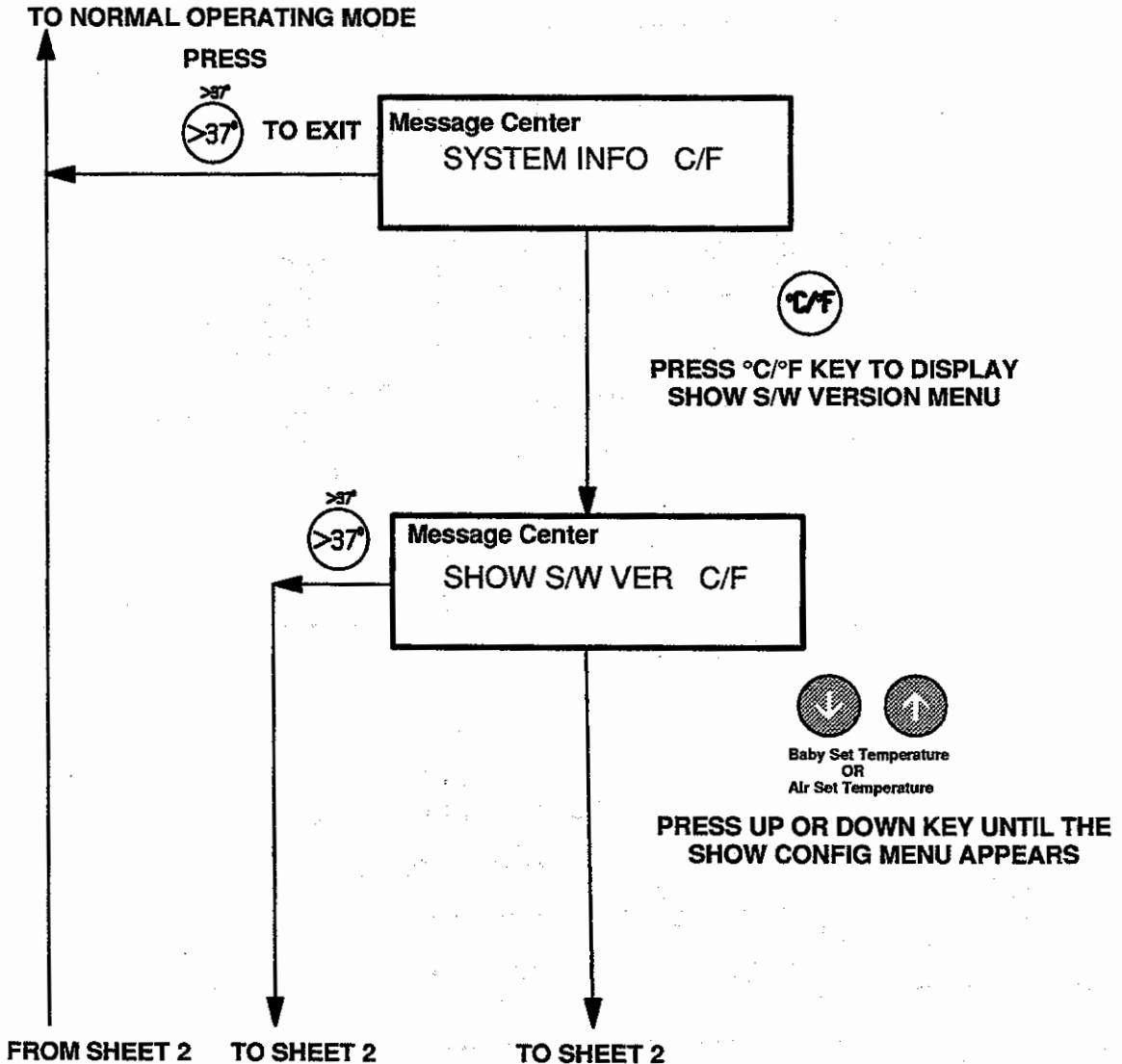

ACCESSING THE CONTROLLER SHOW CONFIG MENU (Sheet 2)

TO SHEET 1 FROM SHEET 1 FROM SHEET 1

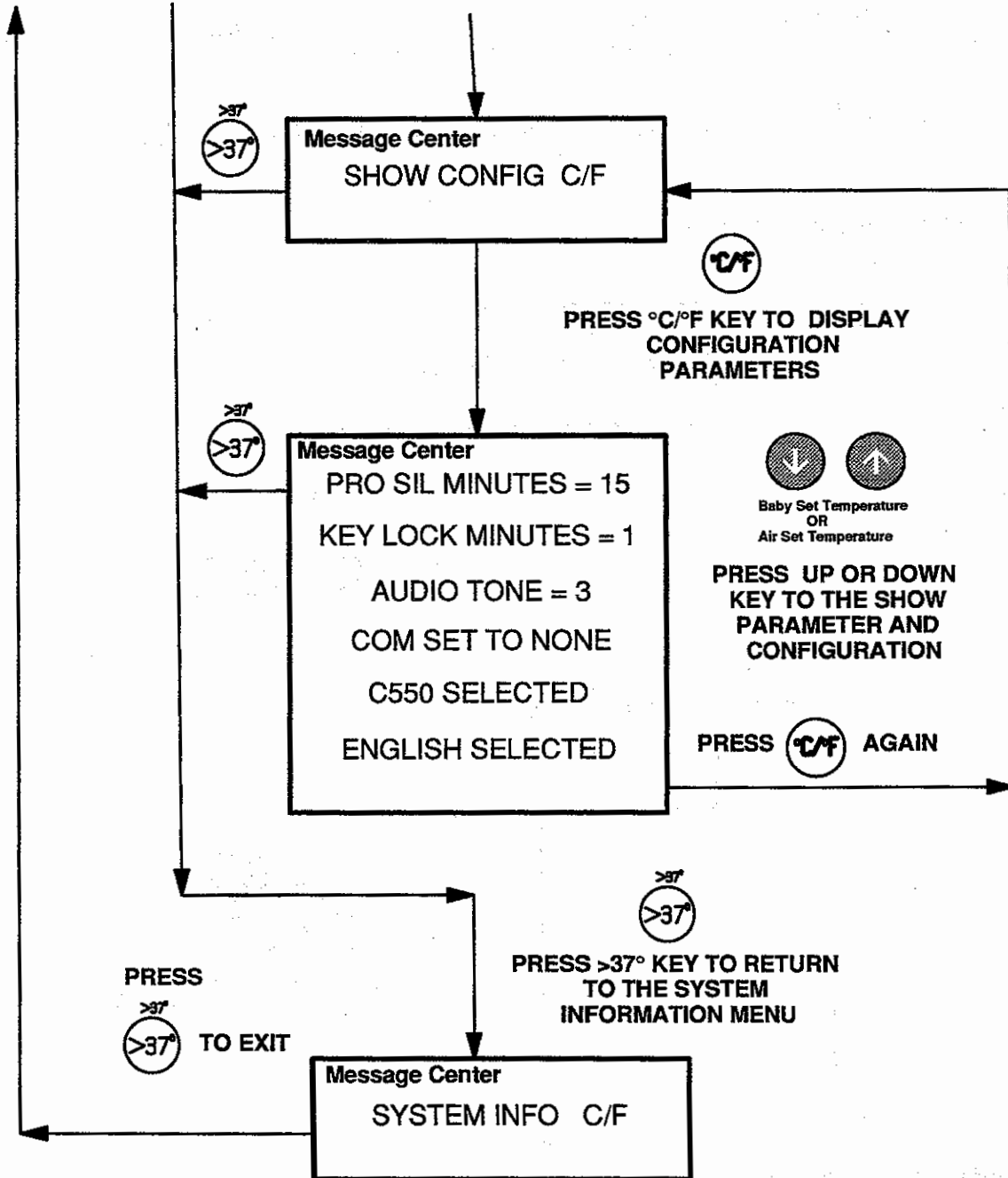

5.4.4 ACCESSING THE CONTROLLER PRINT CONFIGURATION MENU

NOTE: This Menu will appear only when the **SERIAL PORT** located on the Incubator Side Pane has been configured to communicate with a Thermal or a Dot Matrix Printer.

The Controller Print Configuration Menu enables the user to print out the Configurable Incubator Parameters described in Paragraph 5.4.3 above. To access the the Print Configuration Menu, first select the System Information Menu (refer to Paragraph 5.4.1), then proceed as follows:

ACCESSING THE PRINT CONFIG MENU (Sheet 1)

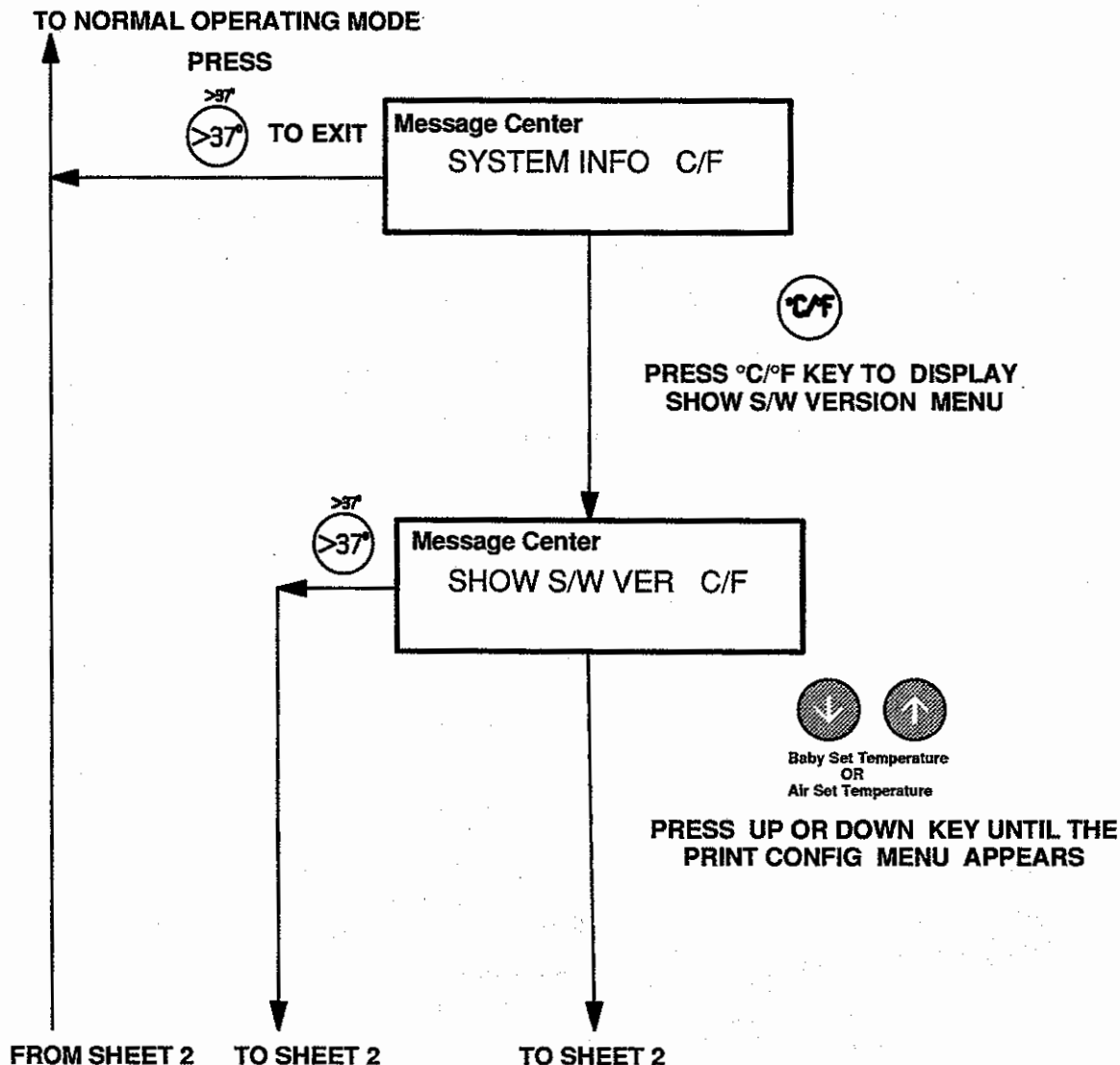

ACCESSING THE PRINT CONFIG MENU (Sheet 2)

TO SHEET 1

FROM SHEET 1

FROM SHEET 1

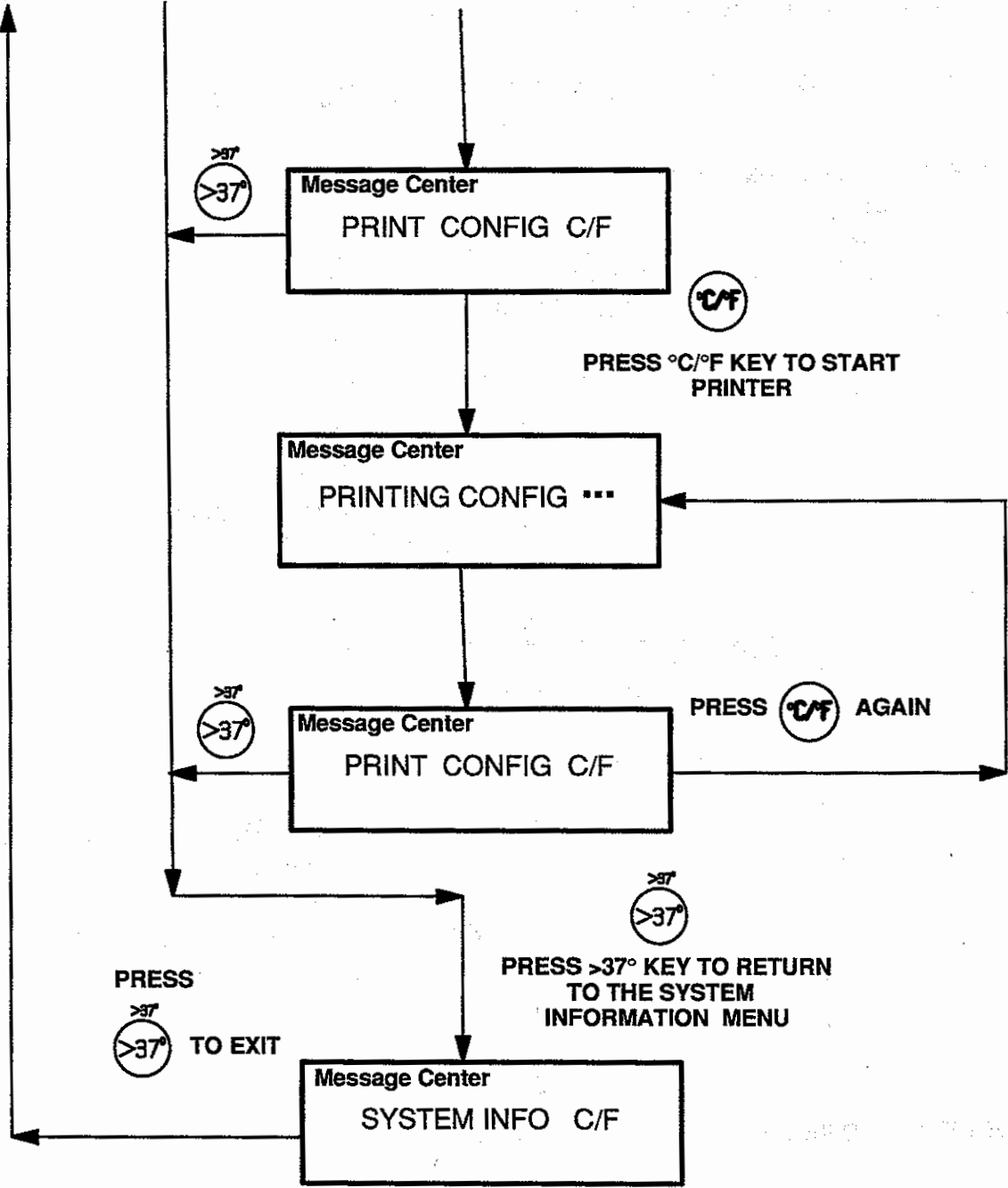

5.4.5 ACCESSING THE CONTROLLER SHOW DIAGNOSTIC LOG MENU

The Diagnostic Log records all internal malfunctions that generated a NEEDS SERVICE NOW Message in the Controller Message Center. The notation of the failure will remain in the log until the log is cleared (Refer to Paragraph 5.4. 7) even though the malfunction has been corrected. In addition, if a printer is available, a print out of the contents of the Diagnostic Log can be obtained by entering the PRINT DIAG LOG Menu (refer to paragraph 5.4.6).

For a listing of the Internal malfunctions that will appear in the Log along with corrective actions, refer to Paragraph 5.6, Troubleshooting.

ACCESSING THE SHOW DIAG LOG MENU (Sheet 1)

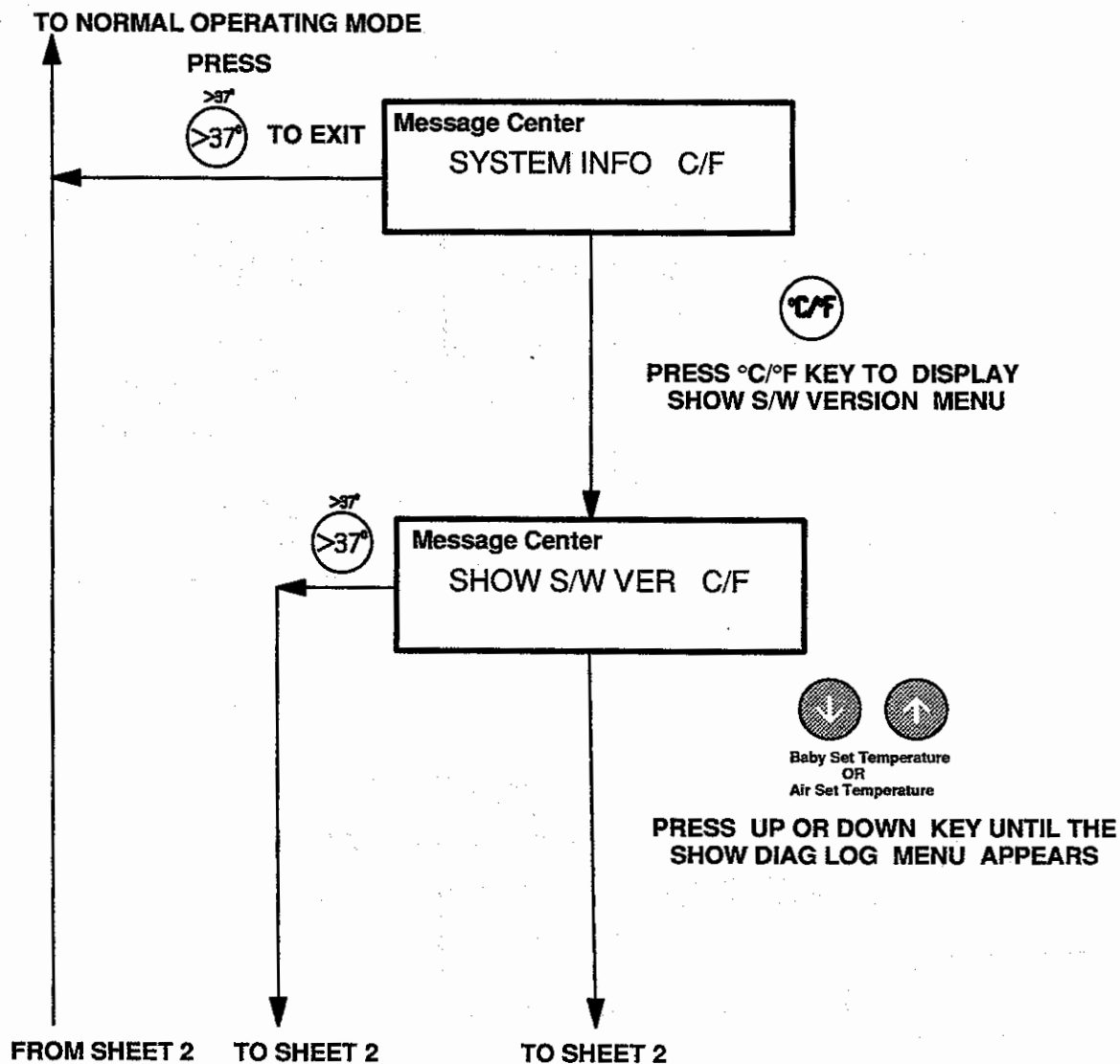

ACCESSING THE SHOW DIAG LOG MENU (Sheet 2)

TO SHEET 1 FROM SHEET 1 FROM SHEET 1

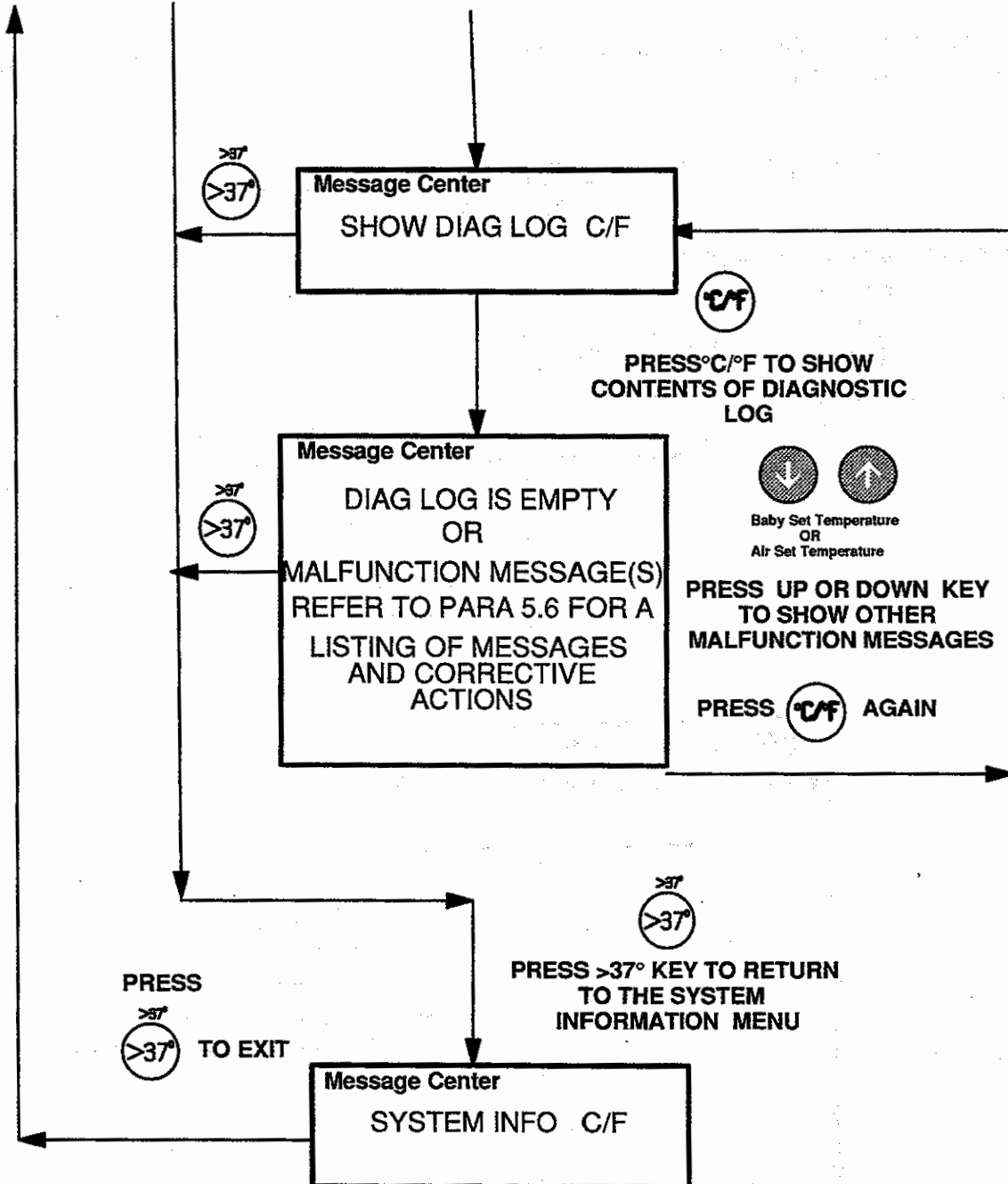

5.4.6 ACCESSING THE CONTROLLER PRINT DIAGNOSTIC LOG MENU

NOTE: This Menu will appear only when the **SERIAL PORT** located on the Incubator Side Pane has been configured to communicate with a Thermal or a Dot Matrix Printer.

The Controller Print Diagnostic Menu enables the user to print out the contents of the Diagnostic Menu described in Paragraph 5.4.4 above. To access the the Print Diagnostic Menu, first select the System Information Menu (refer to Paragraph 5.4.1), then proceed as follows:

ACCESSING THE PRINT DIAG LOG MENU (Sheet 1)

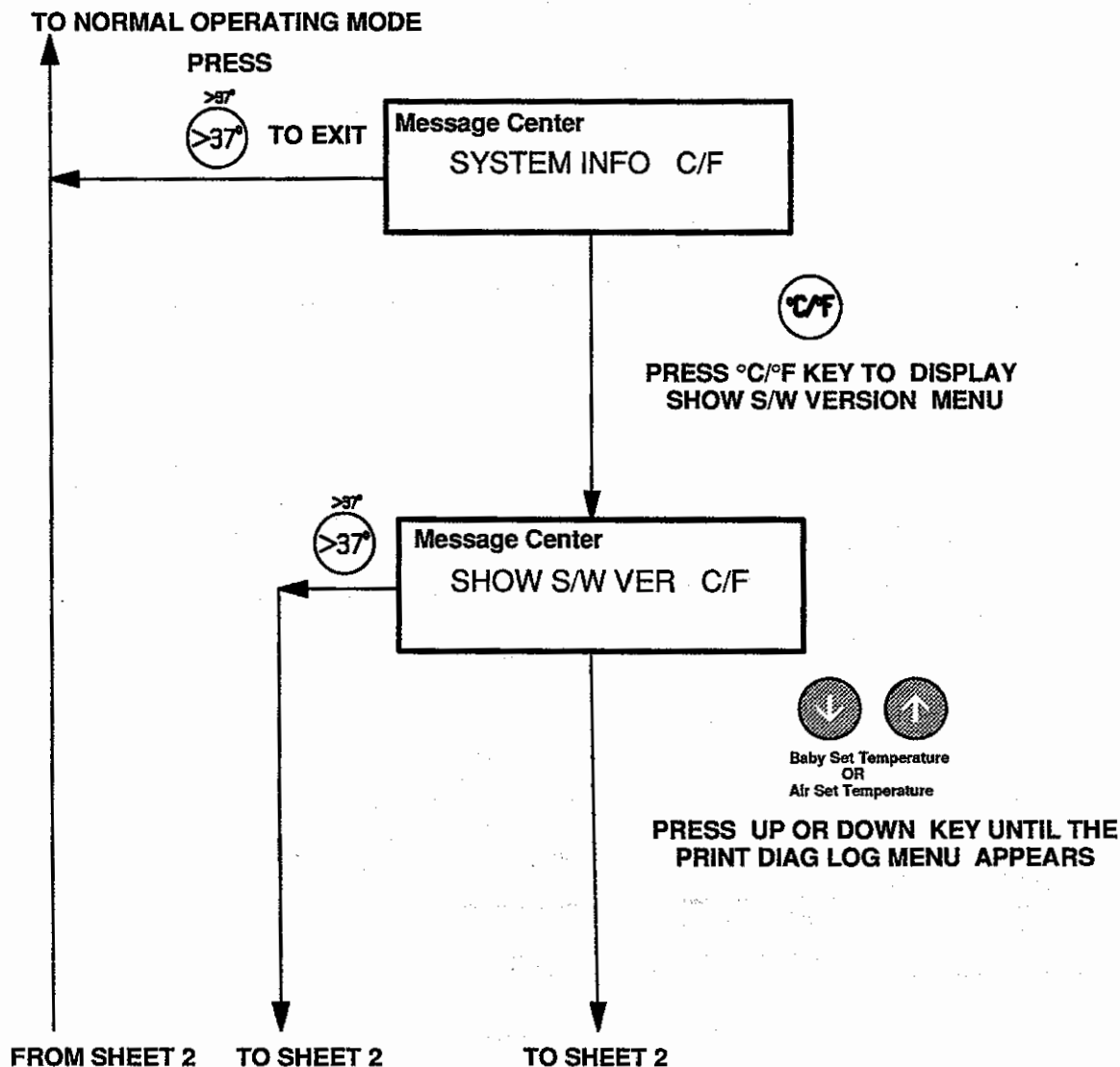

ACCESSING THE PRINTER CONFIG MENU

(Sheet 2)

TO SHEET 1

FROM SHEET 1

FROM SHEET 1

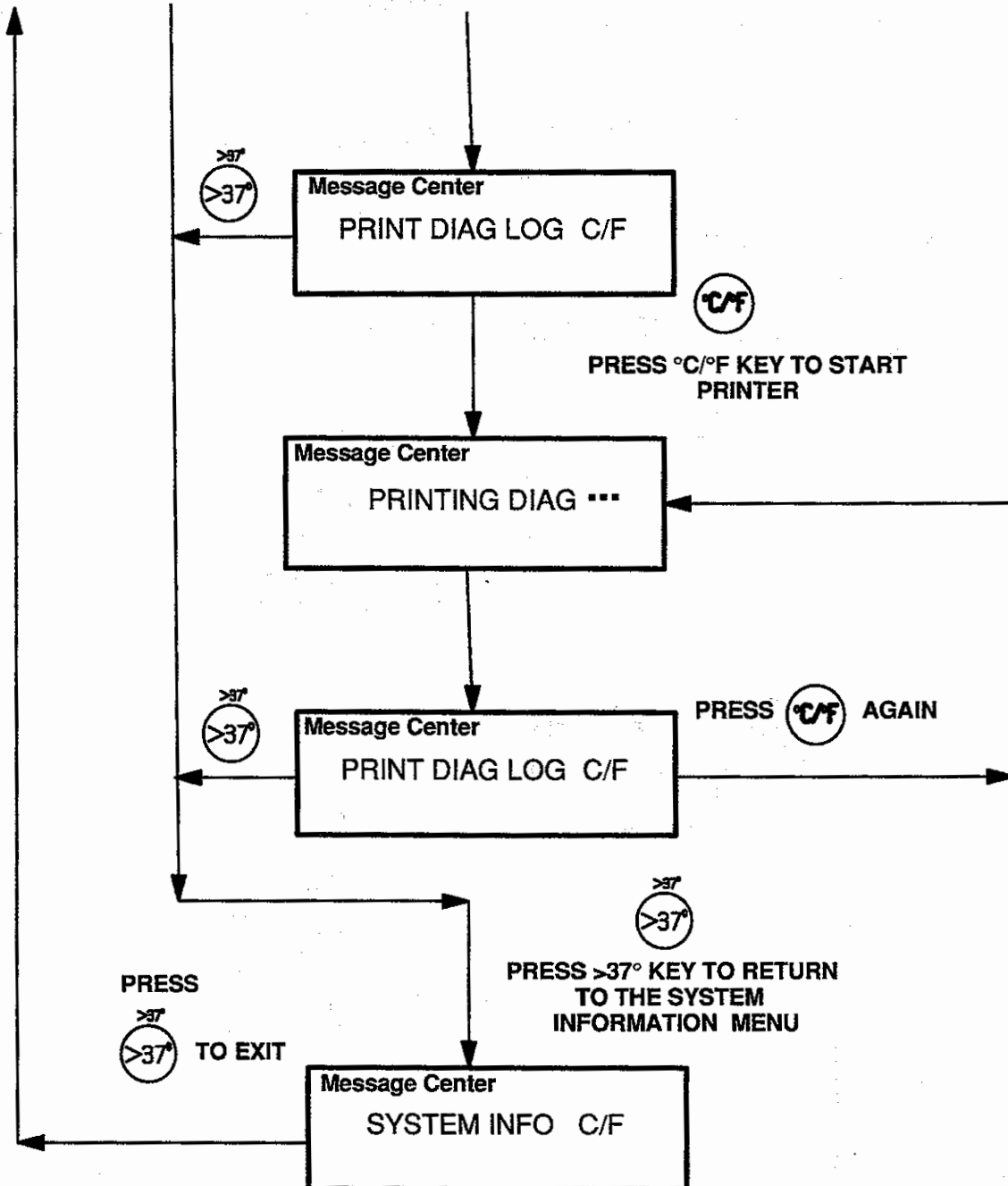

5.4.7 ACCESSING THE CONTROLLER CLEAR DIAGNOSTIC LOG

The Controller Clear Diagnostic Log enables the user to purge the contents of the Diagnostic Log described in Paragraph 5.4.4 above. To access the the Clear Diagnostic Log, first select the System Information Menu (refer to Paragraph 5.4.1), then proceed as follows:

ACCESSING THE CLEAR DIAG LOG (Sheet 1)

TO NORMAL OPERATING MODE

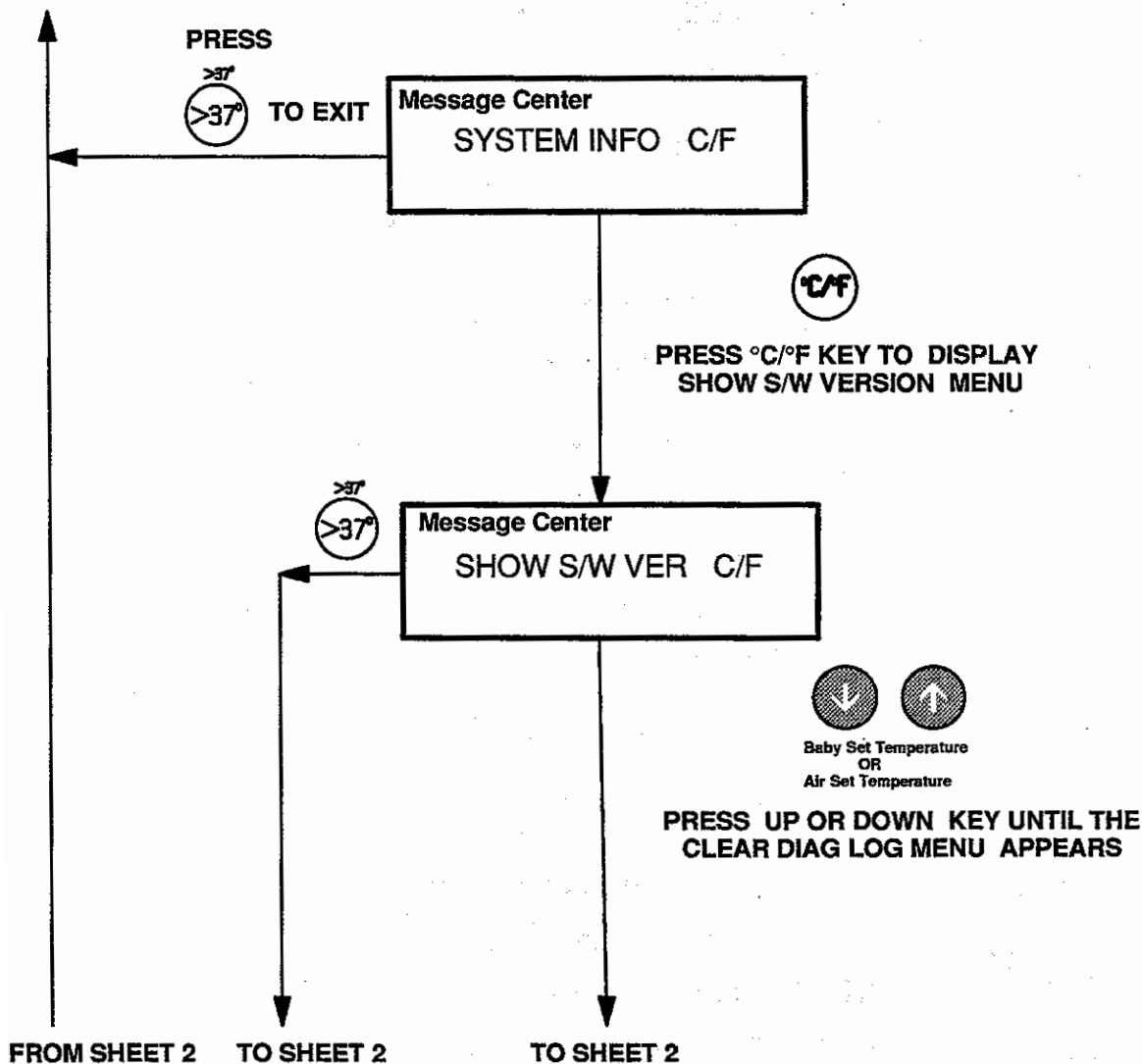

Change 1

ACCESSING THE CLEAR DIAG LOG CONFIG (Sheet 2)

TO SHEET 1

FROM SHEET 1

FROM SHEET 1

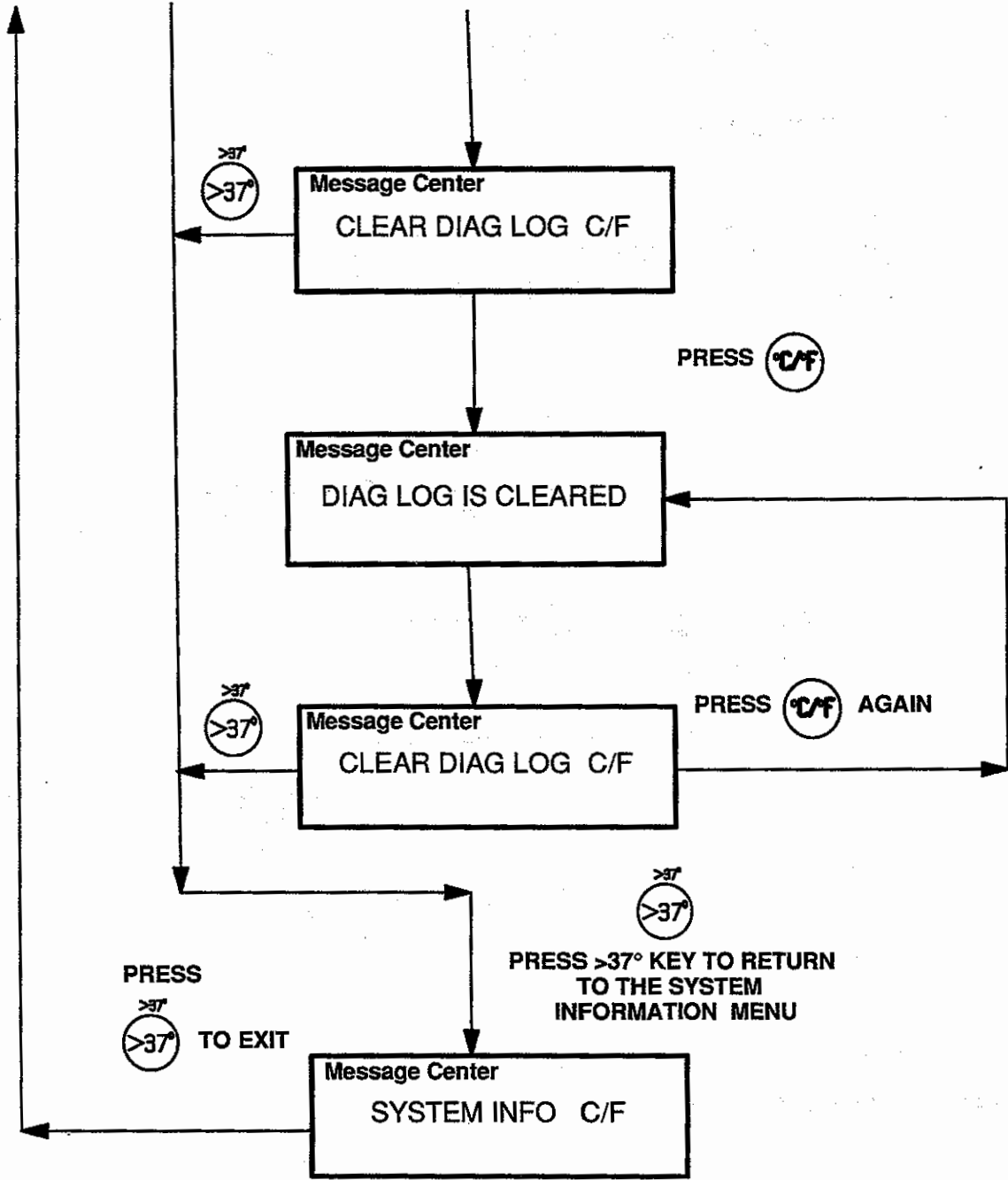

Change 1

5.4.8 ACCESSING THE CONTROLLER MEMORY AVAILABLE MENU

The Controller Memory Available Menu presents the user with the percentage of memory available in the E2 PROM of the processor chip. In the unlikely event that the memory capacity falls below 50%, the processor chip on the Main Controller Board should be replaced. To access the Memory Available Menu, first select the System Information Menu (refer to Paragraph 5.4.1), then proceed as follows:

ACCESSING THE MEM AVAIL MENU (Sheet 1)

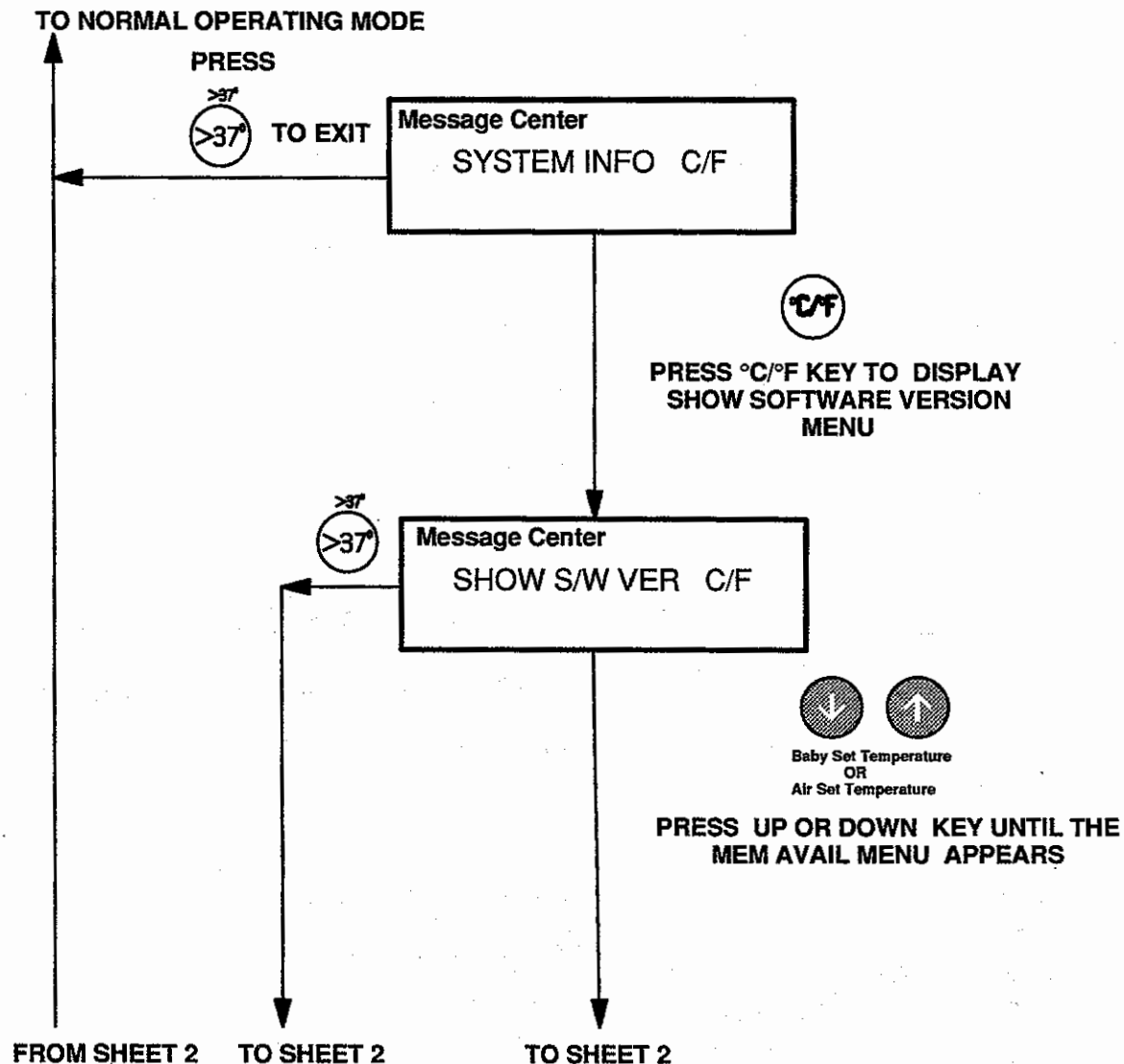

ACCESSING THE MEM AVAIL MENU (Sheet 2)

TO SHEET 1 FROM SHEET 1 FROM SHEET 1

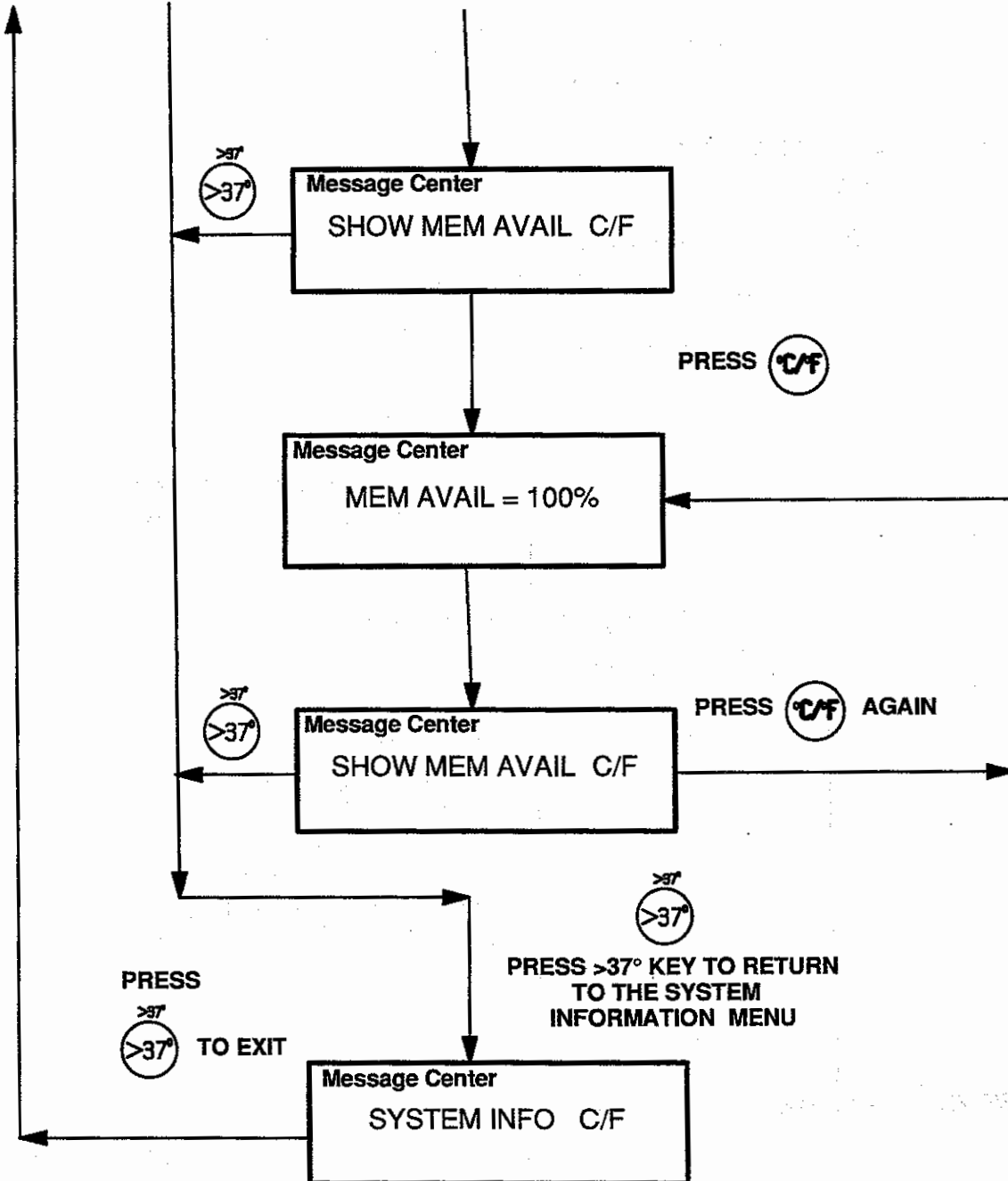

5.5 TEST AND CALIBRATION

5.5.1 GENERAL

Test and Calibration of the Controller is accomplished by use of the Test System Menu (refer to paragraph 5.5.3). The equipment should be completely tested and calibrated at least annually and after any repair.

5.5.2 TEST EQUIPMENT REQUIRED

The test equipment listed below is required for calibration of the Controller and performing Oxygen Concentration tests. Equivalent test equipment may be substituted.

- Digital VOM, Fluke Model 8060A
- Variable Transformer, General Radio Model WSM T3AW
- Leakage Current Tester, Bio-Tek 501
- Flowmeter, Victor Model 1099-0025
- Ringout Probe, Air-Shields Part Number 68 231 20 (English Labeling), 68 231 21 (Spanish Labeling), 68 231 22 (French Labeling) or 68 231 23 (German Labeling)
- Baby Temperature Probe, Air-Shields Part Number 68 209 70

5.5.3 TEST SYSTEM MENU

The Test System Menu may be selected when the SELF-TEST RUNNING Message is appearing in the Message Center.

Before attempting to enter the Test System Menu, refer to Section 3, The Message Center, and Section 4, Operation, Paragraph 4.1, Controls and Indicators, of the Operator's Manual.

THE TEST SYSTEM MENU (Sheet 1 of 13)

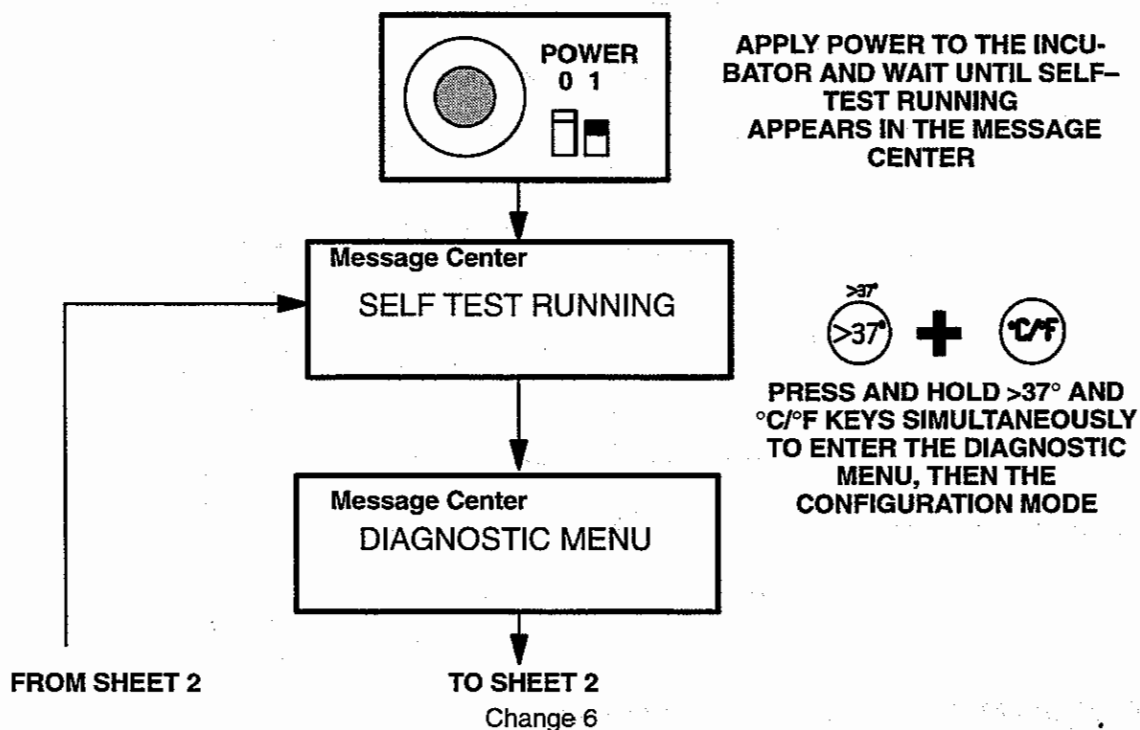

THE TEST SYSTEM MENU (Sheet 2 of 13)

TO SHEET 1

FROM SHEET 1

PRESS

 TO EXIT

Message Center
CONFIGURATION C/F



Baby Set Temperature
OR
Air Set Temperature

PRESS UP OR DOWN KEY
UNTIL TEST SYSTEM C/F
MENU APPEARS IN THE
MESSAGE CENTER

PRESS

 TO EXIT

Message Center
TEST SYSTEM C/F

PRESS

 TO EXIT

Message Center
ROM TEST C/F

PRESS 

PRESS

 TO EXIT

Message Center
TESTING ROM ...

PRESS 

Message Center
ROM TEST PASS
ROM TEST FAIL

IF MESSAGE IS
ROM TEST FAIL
REFER TO PARA. 5.6
TROUBLESHOOTING

PRESS

 TO EXIT

Message Center
ROM TEST C/F



Baby Set Temperature
OR
Air Set Temperature

PRESS THE UP KEY TO
PROCEED

FROM SHEET 3

TO SHEET 3

THE TEST SYSTEM MENU (Sheet 3 of 13)

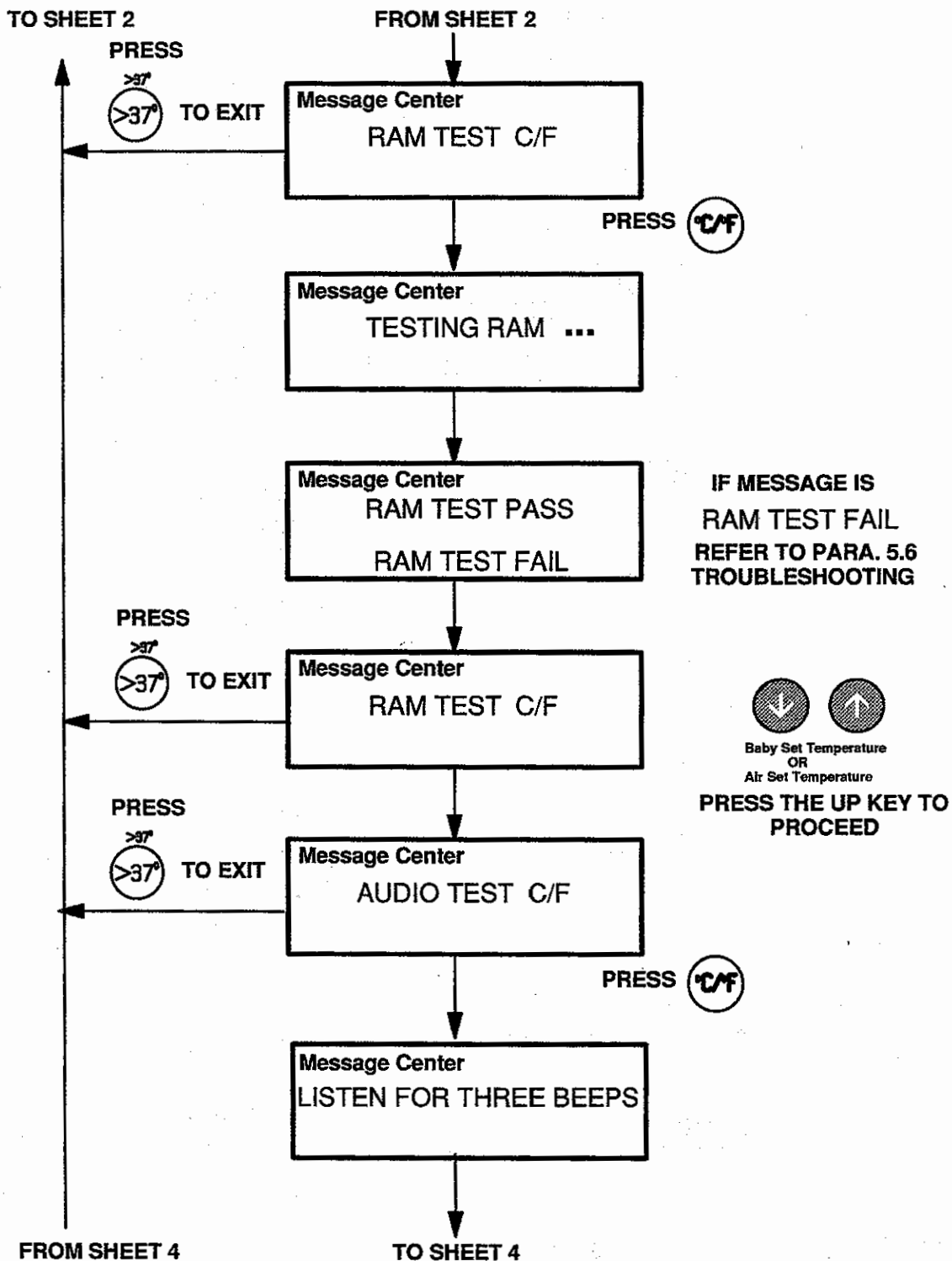

THE TEST SYSTEM MENU (Sheet 4 of 13)

TO SHEET 3

FROM SHEET 3

Message Center
PRESS C/F FOR PASS
PRESS >37 FOR FAIL

 
PRESS THE C/F OR
>37 KEY

Message Center
AUDIO TEST PASS
AUDIO TEST FAIL

IF MESSAGE IS
AUDIO TEST FAIL
REFER TO PARA. 5.6
TROUBLESHOOTING

PRESS
 TO EXIT

Message Center
AUDIO TEST C/F

 
Baby Set Temperature
OR
Air Set Temperature
PRESS THE UP KEY TO
PROCEED

PRESS
 TO EXIT

Message Center
LED TEST C/F

PRESS 

Message Center
TESTING LEDS ...

OBSERVE CONTROLLER
FRONT PANEL AS ALL LED
SEGMENTS AND LEDS ARE
TESTED

Message Center
PRESS C/F FOR PASS
PRESS >37 FOR FAIL

 
PRESS THE C/F OR
>37 KEY

FROM SHEET 5

TO SHEET 5

THE TEST SYSTEM MENU (Sheet 5 of 13)

TO SHEET 4

FROM SHEET 4

Message Center
LED TEST PASS
LED TEST FAIL

IF MESSAGE IS
LED TEST FAIL
REFER TO PARA. 5.6
TROUBLESHOOTING

PRESS



TO EXIT

Message Center
LED TEST C/F



Baby Set Temperature
OR
Air Set Temperature

PRESS THE UP KEY TO
PROCEED

PRESS



TO EXIT

Message Center
VFD TEST C/F

PRESS



Message Center
TESTING VFD ...

OBSERVE MESSAGE CENTER
AS ALL SEGMENTS OF VFD
ARE TESTED. ALL SEGMENTS
SHOULD BE LIT AND OF
EQUAL INTENSITY.



PRESS THE C/F OR
>37 KEY

Message Center
PRESS C/F FOR PASS
PRESS >37 FOR FAIL

Message Center
VFD TEST PASS
VFD TEST FAIL

IF MESSAGE IS
VFD TEST FAIL
REFER TO PARA. 5.6
TROUBLESHOOTING

FROM SHEET 6

TO SHEET 6

THE TEST SYSTEM MENU (Sheet 6 of 13)

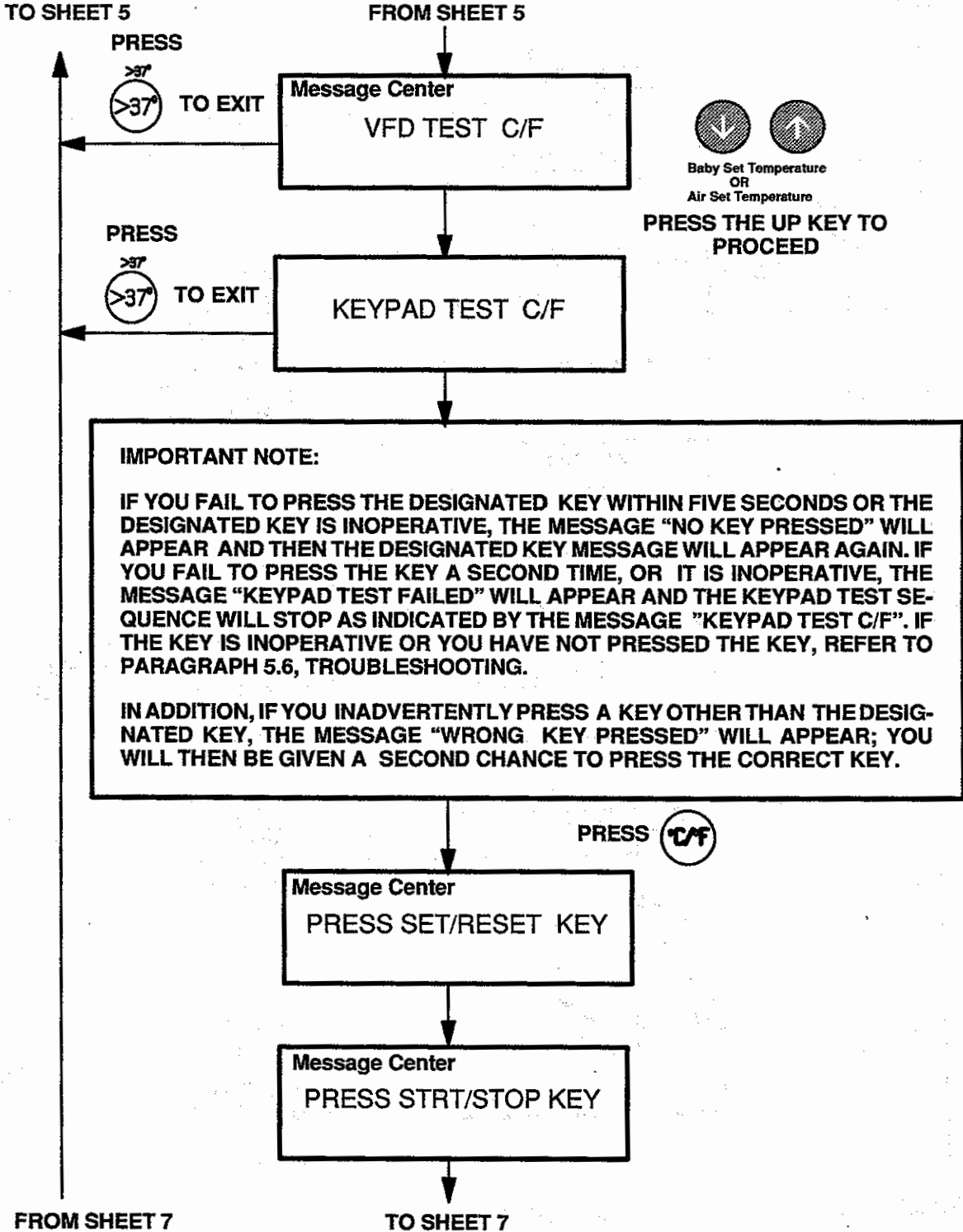

THE TEST SYSTEM MENU (Sheet 7 of 13)

TO SHEET 6

FROM SHEET 6

Message Center
PRESS >37 KEY

Message Center
PRESS BABY MODE KEY

Message Center
PRESS BABY DOWN KEY

Message Center
PRESS BABY UP KEY

Message Center
PRESS AIR MODE KEY

Message Center
PRESS AIR DOWN KEY

FROM SHEET 8

TO SHEET 8

THE TEST SYSTEM MENU (Sheet 8 of 13)

TO SHEET 7

FROM SHEET 7

Message Center
PRESS KEY LOCK KEY

Message Center
PRESS C/F KEY

Message Center
PRESS SILENCE KEY

Message Center
KEYPAD TEST PASS

PRESS



TO EXIT

Message Center
KEYPAD TEST C/F



Baby Set Temperature
OR
Air Set Temperature

PRESS THE UP KEY TO
PROCEED

PRESS



TO EXIT

Message Center
RS-232 TEST C/F

PRESS



FROM SHEET 9

TO SHEET 9

THE TEST SYSTEM MENU (Sheet 9 of 13)

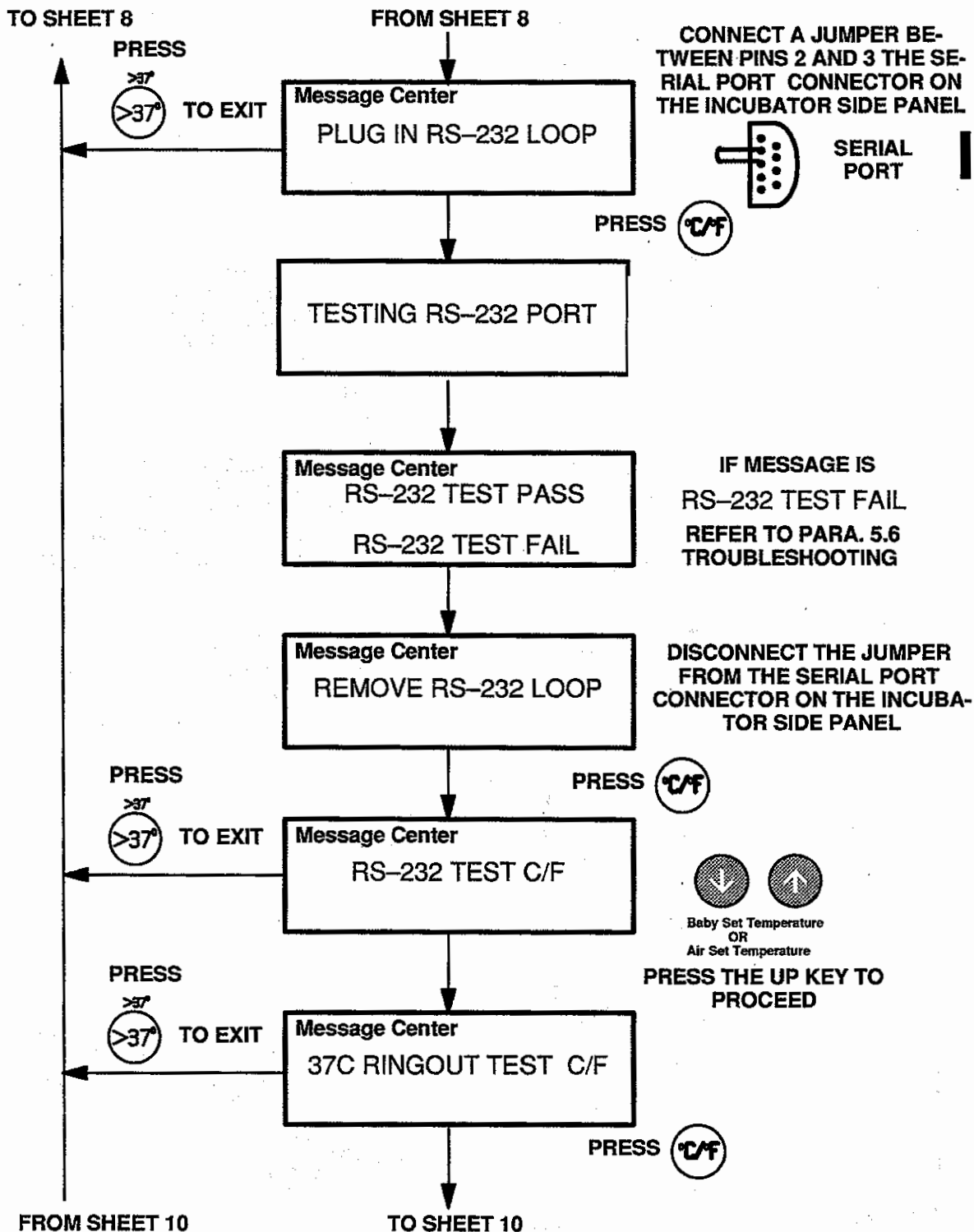

Change 1

THE TEST SYSTEM MENU (Sheet 10 of 13)

TO SHEET 9

FROM SHEET 9

Message Center
SELECT BABY/AIR MODE

SELECT AIR MODE

PRESS



TO EXIT

Message Center
INSERT RINGOUT PROBE

CONNECT THE RINGOUT
PROBE TO THE AUXILIARY AIR
PROBE CONNECTOR ON THE
SIDE PANEL

PRESS



Message Center
37C RINGOUT RUNNING

ALL SEGMENTS OF THE
HEATER POWER% DISPLAY
SHOULD BE ON. THE AIR TEM-
PERATURE DISPLAY SHOULD
BE ON AND SLOWLY RISING.

Message Center
RINGOUT COMPLETE

WHEN THE AIR TEMPERA-
TURE DISPLAY REACHES
37 °C THE AUDIBLE
ALARM WILL SOUND.

PRESS



TO EXIT

Message Center
PRESS SILENCE/RESET

Message Center
REMOVE RINGOUT PROBE

DISCONNECT THE RINGOUT
PROBE TO THE AUXILIARY AIR
PROBE CONNECTOR ON THE
SIDE PANEL

PRESS



FROM SHEET 11

TO SHEET 11

Change 2

THE TEST SYSTEM MENU (Sheet 11 of 13)

TO SHEET 10

FROM SHEET 10

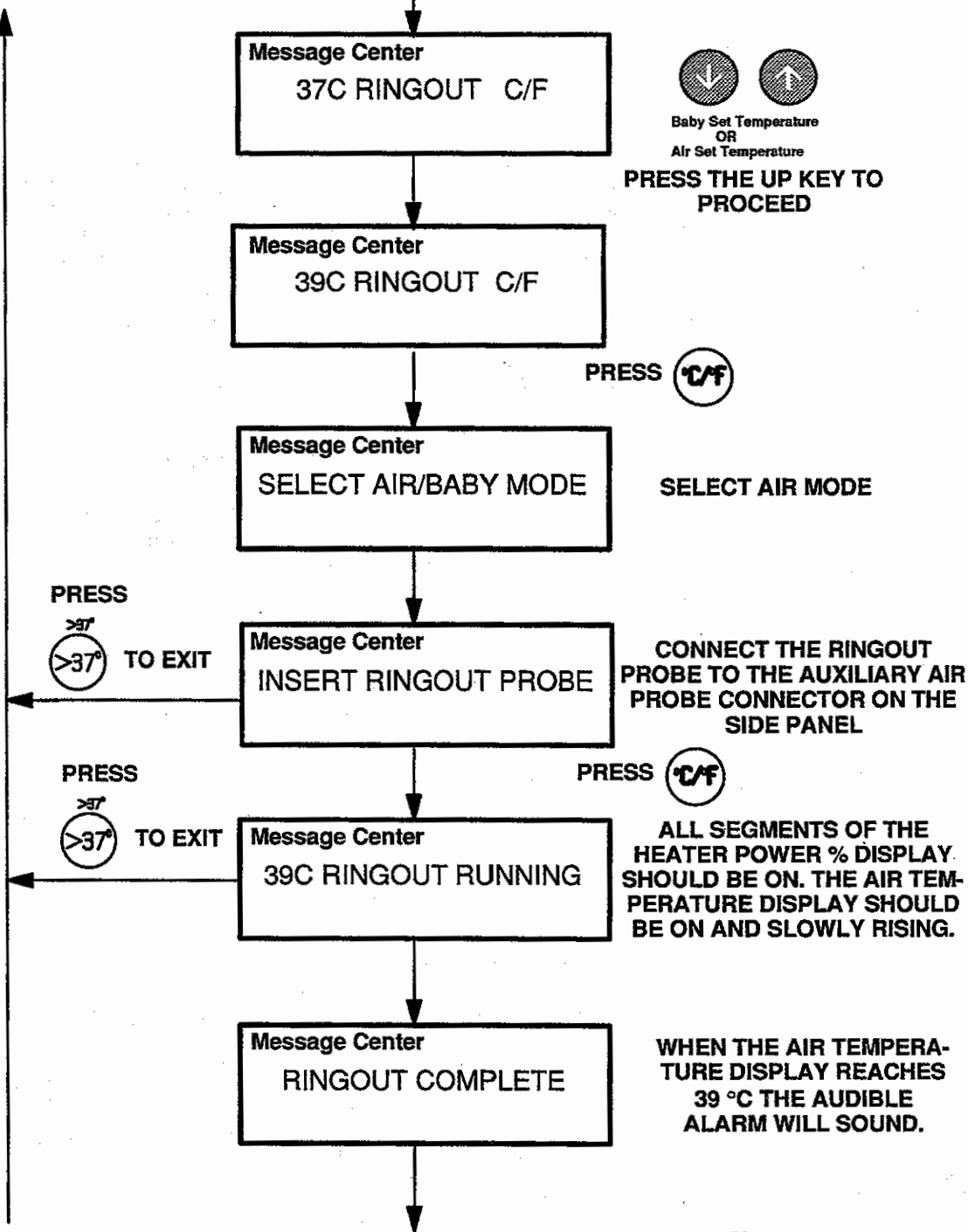

THE TEST SYSTEM MENU (Sheet 12 of 13)

TO SHEET 11

FROM SHEET 11

Message Center
PRESS SILENCE/RESET

Message Center
REMOVE RINGOUT PROBE

DISCONNECT THE RINGOUT
PROBE TO THE AUXILIARY AIR
PROBE CONNECTOR ON THE
SIDE PANEL

PRESS 

Message Center
39C RINGOUT C/F





Baby Set Temperature
OR
Air Set Temperature

PRESS THE UP KEY TO
PROCEED

PRESS
 TO EXIT

Message Center
CALIBRATE FAN C/F

PRESS 

PRESS
 TO EXIT

Message Center
TESTING FAN SPEED

Message Center
FAN IS CALIBRATED

IF MESSAGE IS
FAN OVER SPEED
OR
FAN UNDER SPEED
REFER TO PARA. 5.5.4 FOR
CALIBRATION PROCEDURE

PRESS 

FROM SHEET 13

TO SHEET 13

Change 4

THE TEST SYSTEM MENU (Sheet 13 of 13)

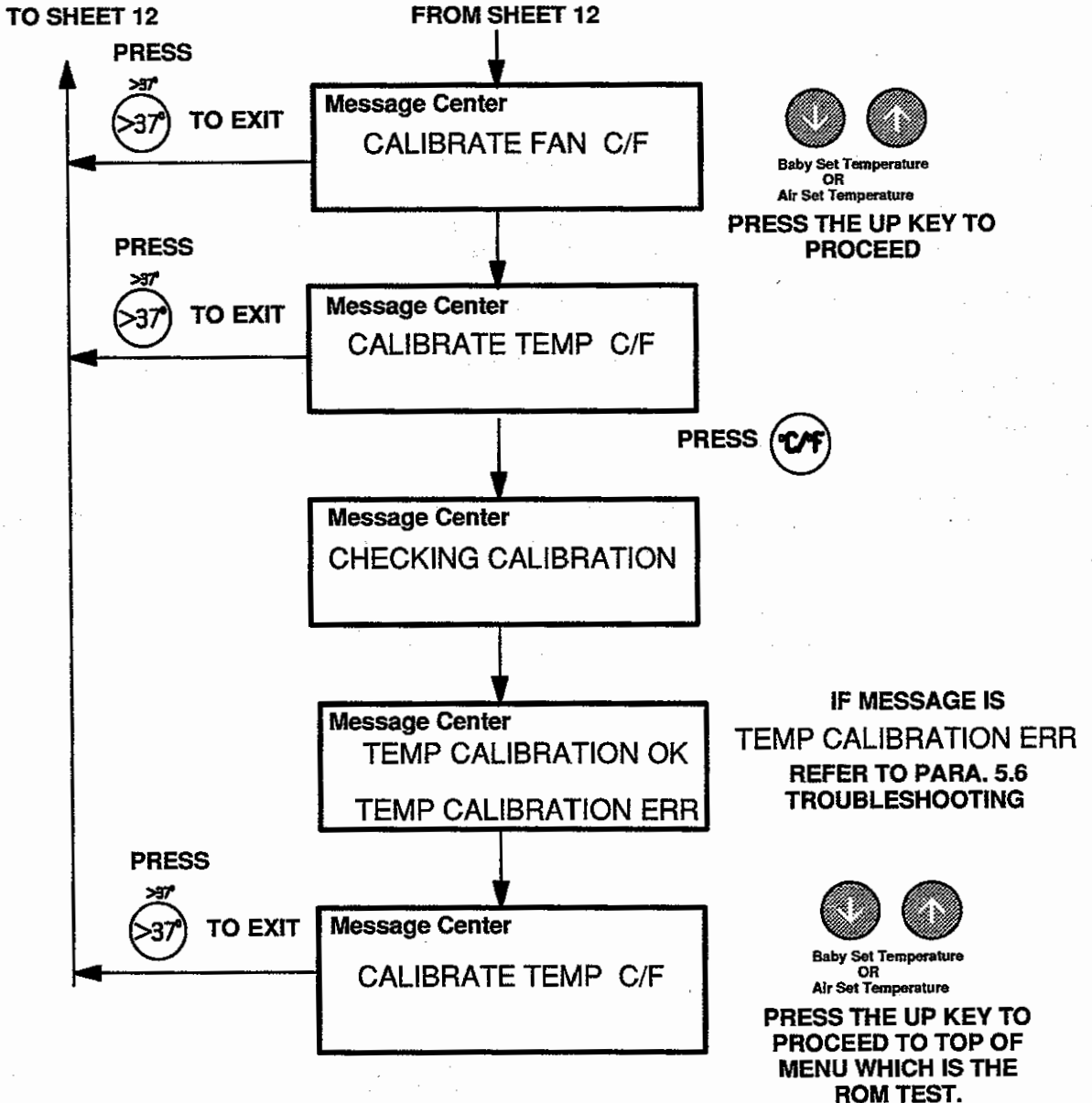

5.5.4 FAN SPEED AND AC LINE MONITORING CALIBRATION

FAN SPEED CALIBRATION (REFER TO FIGURE 5. 2 FOR ADJUSTMENT LOCATION)

Fan Speed Calibration is accomplished by first entering the System Test Menu and then paging down to the CALIBRATE FAN C/F Section of the Menu.

Note: The Fan Speed adjustment should be attempted only when the System Test Menu presents one of the following Messages:

FAN UNDER SPEED

FAN OVER SPEED

1. Enter the Test System Menu and page down to the CALIBRATE FAN C/F Section.
2. Press the C/F key, adjust R26 on the Heater Board until the message FAN CALIBRATED replaces the FAN UNDER SPEED or FAN OVER SPEED message.
3. Enter the System Information Menu (Paragraph 5.4) and clear the Diagnostic Log.

AC LINE MONITORING CALIBRATION (REFER TO FIGURE 5. 2 FOR TEST POINT AND ADJUSTMENT LOCATIONS)

TEST SET-UP

1. Connect the Controller to the variable transformer and set the transformer to 120 Vac (220 Vac or 100 Vac as appropriate). Connect the VOM to TP2 (+) and TP1 (-) on the Heater Board.

PROCEDURE

1. Adjust R27 on the Heater Board for a reading of 6.00 ± 0.01 Vdc on the VOM.

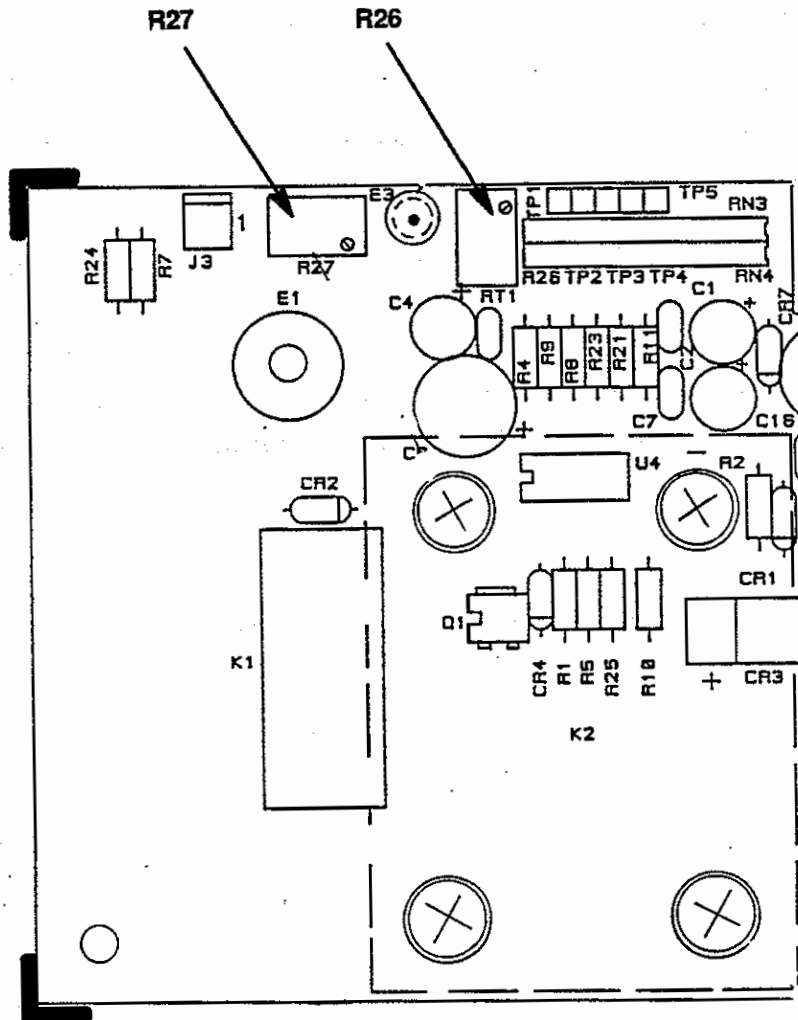

FIGURE 5.2 LOCATION OF HEATER BOARD FAN SPEED AND TEMPERATURE CALIBRATION POTENTIOMETERS

5.5.5 LEAKAGE CURRENT TESTS

TEST SET-UP

1. Connect the Controller to the primary power source through an ungrounded adapter plug, so that the unit is ungrounded. Turn the POWER switch on.
2. The leakage current test standards provided in the procedure below assume leakage through a resistance of 1000 Ohms. If the Leakage Tester being used does not provide this resistance, the test set-up must be adjusted to provide it.

PROCEDURE

1. Use the Leakage Current Tester to measure between the chassis of the unit under test and a known ground such as the ground connection of a wall receptacle. The leakage current must not exceed 100 micro-amps in 120 Vac Units or 500 micro-amps in 220/240 Vac Units.
2. Reverse the plug and repeat step 1.
3. Perform Steps 1 and 2 with the Controller POWER switch OFF.

5.5.6 OXYGEN CONCENTRATION TESTS

Note: This test is applicable only to units that do not have an Oxygen or Saturation Controller attached to the Filter Cover.

TEST-SETUP

1. Place a calibrated oxygen analyzer on the mattress in the Incubator.
2. Apply oxygen at a flow rate of 8 LPM to the O₂ nipple on the Filter Cover.

PROCEDURE

1. Turn the unit ON.
2. After 40 minutes of operation, verify that the oxygen concentration level is between 37% and 48%.
3. Increase the Oxygen flow to 12 LPM. After another 40 minutes of operation, verify that the oxygen concentration level is between 65% and 95%.

5.6 TROUBLESHOOTING

When the Controller experiences an internal malfunction, the message NEEDS SERVICE NOW will be displayed in the Message Center and the Audible Alarm will sound continuously. If the malfunction is still present after the Incubator has been turned off and then turned on again, the NEEDS SERVICE NOW message will appear after the Incubator has completed its Self-Test routine.

To determine what has caused or where the failure is located, the operator must access the Diagnostic Log located in the System Information Menu. The Diagnostic Log records all internal malfunctions that generated a NEEDS SERVICE NOW Message in the Controller Message Center. To access the Diagnostic Log, refer to Paragraph 5.4.5. If a printer is available, a print-out of the contents of the Diagnostic Log may be obtained by entering the PRINT DIAG LOG Menu (refer to paragraph 5.4.6).

IMPORTANT: The notation of a malfunction will remain in the Diagnostic Log until the log is cleared (Refer to Paragraph 5.4.7), even though the malfunction has been corrected.

Table 5.1 presents a listing of all Malfunction Messages that will appear in the Diagnostic Log, along with an explanation of each Message and possible corrective actions for the malfunction.

TABLE 5.1 DIAGNOSTIC LOG MESSAGES AND CORRECTIVE ACTIONS

MESSAGE	EXPLANATION	POSSIBLE CORRECTIVE ACTION
HIGH TEMP PROBE FAIL	High Temperature Probe Failure	<ol style="list-style-type: none"> 1. Replace High Temperature Probe. 2. Replace Main Board.
AIR FLOW PROBE FAIL	Air Flow Probe Failure	<ol style="list-style-type: none"> 1. Replace Air Flow Probe. 2. Replace Main Board.
FAN OVER SPEED	Fan Motor running to fast	<ol style="list-style-type: none"> 1. Refer to para. 5.5.4 and perform Fan Motor Adjustment Procedure. 2. Replace Heater Board. 3. Replace Fan Motor. 4. Replace heater Bd to Main Bd Cable.
FAN UNDER SPEED	Fan Motor running to slow.	<ol style="list-style-type: none"> 1. Refer to para. 5.5.4 and perform Fan Motor Adjustment Procedure. 2. Replace Heater Board. 3. Replace Fan Motor. 4. Replace heater Bd to Main Bd Cable.
KEYPAD TEST FAIL	One of the Front Panel Keys has failed to operate.	<ol style="list-style-type: none"> 1. Replace Front Panel Overlay. 2. Replace Display Board. 3. Replace Main Board.
EEPROM TEST FAIL	E ² PROM has failed	<ol style="list-style-type: none"> 1. Replace Processor U1 on Main Board.

TABLE 5.1 DIAGNOSTIC LOG MESSAGES AND CORRECTIVE ACTIONS (Cont.)

MESSAGE	EXPLANATION	POSSIBLE CORRECTIVE ACTION
RAM TEST FAIL	Internal volatile Memory failure	1. Replace Processor U1 on Main Board.
ROM TEST FAIL	Program Memory failure	1. Replace EPROM U2 on Main Board.
ADC 0 VREF ERROR	The microprocessor has detected an error in the Monitor Hybrid R/D Converters reference voltage.	1. Replace Monitor Hybrid. 2. Replace Main Board.
ADC 5 VREF ERROR	The microprocessor has detected an error in the Monitor Hybrid R/D Converters reference voltage.	1. Replace Monitor Hybrid. 2. Replace Main Board.
DAC MIN CNT ERROR	The microprocessor has detected an error in the Control Hybrid D/A Converter	1. Replace Control Hybrid. 2. Replace Main Board.
DAC SET ERROR	The microprocessor has detected an error in the Control Hybrid D/A Converter	1. Replace Control Hybrid. 2. Replace Main Board.
PWR SUPPLY 1 FAIL	The microprocessor has detected an error in the +24 V or -12V Supplies	1. Replace Power Supply. 2. Replace Processor U1 on Main Board. 3. Replace Main Board. 4. Replace Pwr Supply to Main Bd Cable.
PWR SUPPLY 2 FAIL	The microprocessor has detected an error in the +12 V or -5V Supplies	1. Replace Power Supply. 2. Processor U1 on Main Board. 3. Replace Main Board. 4. Replace Pwr Supply to Main Bd Cable.
BATTERY FAILURE	The microprocessor has detected an error in PFA Battery on the Display Board	1. Replace Battery on Display Board. 2. Replace Display Board. 3. Replace Processor U1 on Main Board. 4. Replace Main Board. 5. Replace Display Bd to Main Bd Cable.
TEMP CALIBRATION ERROR	The microprocessor has detected an error in the temperature conditioning signal path	1. Replace Monitor Hybrid. 2. Replace Control Hybrid. 3. Replace Main Board.
HEATER BOARD FAIL	The microprocessor has detected an error in the Heater Board	1. Replace F1 on the Heater Board. 2. Replace Heater Board. 3. Replace AC Entry Bd to Heater Bd Cable.

TABLE 5.1 DIAGNOSTIC LOG MESSAGES AND CORRECTIVE ACTIONS (Cont.)

MESSAGE	EXPLANATION	POSSIBLE CORRECTIVE ACTION
INT TEMP TOO HIGH	The microprocessor has detected that the Controller internal temperature is too high.	<ol style="list-style-type: none"> 1. Replace Cooling Fan. 2. Replace Heater Board. 3. Replace Heater Bd to Main Bd Cable.
RS-232 FAILURE	Either the data receive or transmit line from the isolated serial port is non-functional.	<ol style="list-style-type: none"> 1. Replace Main Board.
VFD TEST FAIL	This message was entered when the user observed a failure in one or more of the Message Center Characters.	<ol style="list-style-type: none"> 1. Replace VFD Module.
LED TEST FAIL	This message was entered when the user observed a failure of a LED or a segment of a LED.	<ol style="list-style-type: none"> 1. The following LEDs are mounted on sockets and may be replaced. DS9 thru DS16, 18,19 DS 21,22, 23, 24, 25, 26 27, 28, and 29. 2. Replace the Display Board
AUDIO TEST FAIL	This message was entered when the user failed to hear the three Beeps generated by the Audio Test.	<ol style="list-style-type: none"> 1. Replace Speaker on Display Board. 2. Replace Display Board. 3. Replace Display Bd to Main Bd Cable. 4. Replace Main Board.

5.7 REMOVAL AND REPLACEMENT PROCEDURES

5.7.1 GENERAL

This section provides removal and replacement procedures for components of the Incubator. Removal and replacement procedures for components other than those provided are obvious upon inspection.

5.7.2 CONTROLLER FRONT PANEL AND CONTROLLER PRINTED CIRCUIT BOARDS

Note: Refer to Figure 6.4, Sheet 2, for the Locations of the Printed Circuit Boards.

CONTROLLER FRONT PANEL

1. Refer to Section 4.2.1, Step A, and remove the Controller from the unit.
2. Remove the four Phillips Head screws located behind the handles.
3. Disconnect the Ribbon Cable from J8 on the Main Printed Circuit Board.
4. Refer to Figure 6.4, Sheet 2, and disconnect the Front Panel Overlay Ground Strap from the Chassis by removing the Nut (Item 57) and Washer (item 58).

DISPLAY BOARD

1. Remove the Controller Front panel as described above.
2. Disconnect P2 and P3 from their connectors.
3. Remove the seven screws that hold the Display Board to the Front Panel.
4. To replace the board, reverse Steps 1 through 3.

MAIN PRINTED CIRCUIT BOARD

1. Remove the Controller Front panel as described above.
2. Disconnect P2, P3 and P6 from their connectors.
3. Use long-nose pliers to remove the board from the 2 snap-in board supports on the left side. Remove the top screw holding Connector J3 and the screw located at the upper right corner.
4. To replace the board, reverse Steps 1 through 3.

IMPELLER FAN MOTOR AND AIR FLOW PROBE

1. Remove the Front Panel and Main Board as described above.
2. To remove the Fan Motor, refer to Figure 6.4, Sheet 1, and reference Items 3, 4, 6, 7, 8 and 9.
3. To remove the Air Flow Probe, refer to Figure 6.4, Sheet 1, and reference Items 27, 28, 29 and 30.
4. For reassembly, reverse Steps 1 and 2 or Steps 1 and 3.

AC ENTRY BOARD AND CHASSIS RIGHT SIDE PANEL

1. Remove the Front Panel and Main Board as described above.

2. Disconnect the connectors from J2 and J3.
3. Remove the four screws located on the right side of the Chassis.
4. To replace the Board and Chassis, reverse Steps 1 through 3.

AIR TEMPERATURE PROBE

1. Remove the Front Panel, Main Board and ac Entry and Chassis as described above.
2. To remove the Air Temperature Probe refer to Figure 6.4, Sheet 1, and reference Items 20 through 26.
3. To replace the probe, reverse Steps 1 and 2.

HEATER BOARD

1. Remove the Front Panel.
2. Remove the nuts and washers from E1 and E2. Remove the screws located at the lower left and upper right corners of the board.
3. To replace the board, reverse Steps 1 and 2.

HEATER

1. Remove the Front Panel and the Heater Board as described above.
2. Refer to Figure 6.4, Sheet 1, and reference Items 10, 15 and 16.
3. To replace the heater, reverse Steps 1 and 2.

POWER SUPPLY

1. Remove the Front Panel as described above.
2. Remove the 2 screws located directly under the Heater on the Chassis rear panel. Remove the 2 screws located at the front corners of the Power Supply Board.
3. To replace the Power Supply, reverse Steps 1 and 2.

5.7.3 PNEUMATIC FRONT PANEL

1. Refer to Section 4.2.1, Step A, and remove the Controller from the unit.
2. Slide the Pneumatic Panel to the right as far as it will go. Lift the Panel out of its Keyhole slots.
3. Remove the White, Red and Blue tubes from the Y Connectors by pressing on the Red Collar of the Connector and pulling out the tube.
4. To replace the Pneumatic Panel, refer to Figure 7.1, Pneumatic Tubing Diagram, and reconnect the White, Blue and Red tubes to the Y Connectors.
5. Replace the panel in its keyhole slots and slide it to the left as far as it will go.

5.7.4 OXYGEN INPUT VALVE FILTER CARTRIDGE

1. Refer to Figure 5.3 and remove the three screws which hold the Input Valve to the Air Intake Filter Cover.
2. Replace the Filter Cartridge (Part No. 68 130 67) and reassemble the Oxygen Input Valve as shown in Figure 5.3.

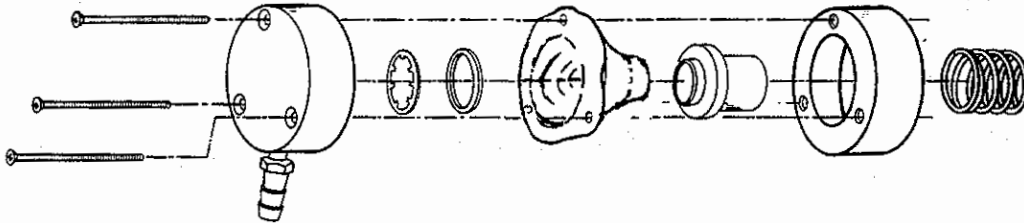

FIGURE 5.3 OXYGEN INPUT VALVE ASSEMBLY

5.7.5 VHA STAND

VHA STAND ACTUATOR

Refer to Figure 6.14 for all references in parentheses ().

1. Remove the Incubator from the VHA Stand.
2. Remove the cable clamps (35) from the Platform (13).
3. Remove the 8 nuts (50) from the top of the Platform (13). Remove the Platform from the Stand.
4. Pull the Escutcheon (16) straight up and off the stand.

CAUTION: Do not pull Inner Column Assembly (14) up to extend the Gibs (Item 2, Figure 6.15) beyond the top surface of the outer column. If this has been inadvertently done, the Inner Column Assembly must be completely removed and then reassembled using the Procedures described in Para. 5.7.6.

5. Remove the Ground Lug and Cable Clamp (36) at the top of the post by removing the nuts (49).
6. Remove the Mains Panel (8). Disconnect the White Wire from the MAIN POWER Switch (refer to Figure 5.4 for 120V Units or Figure 5.5 for 220V/240V Units).
7. Disconnect the Blue Wire and Brown Wires of the Incubator Power Cord from the MAIN POWER Switch (refer to Figure 5.4 for 120V Units or Figure 5.5 for 220/240V Units).

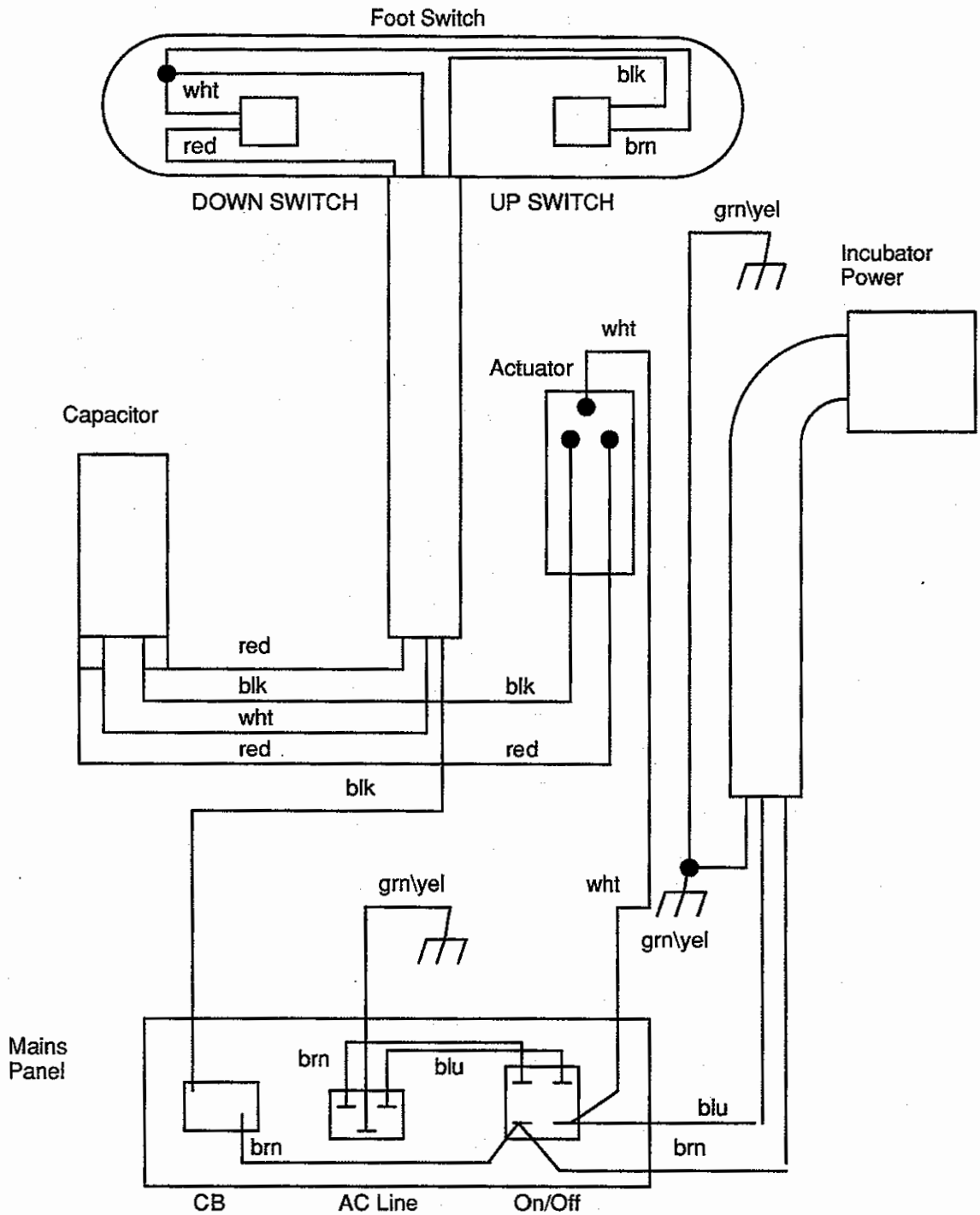

FIGURE 5.4 VHA STAND WIRING DIAGRAM-120V UNITS

Change 1

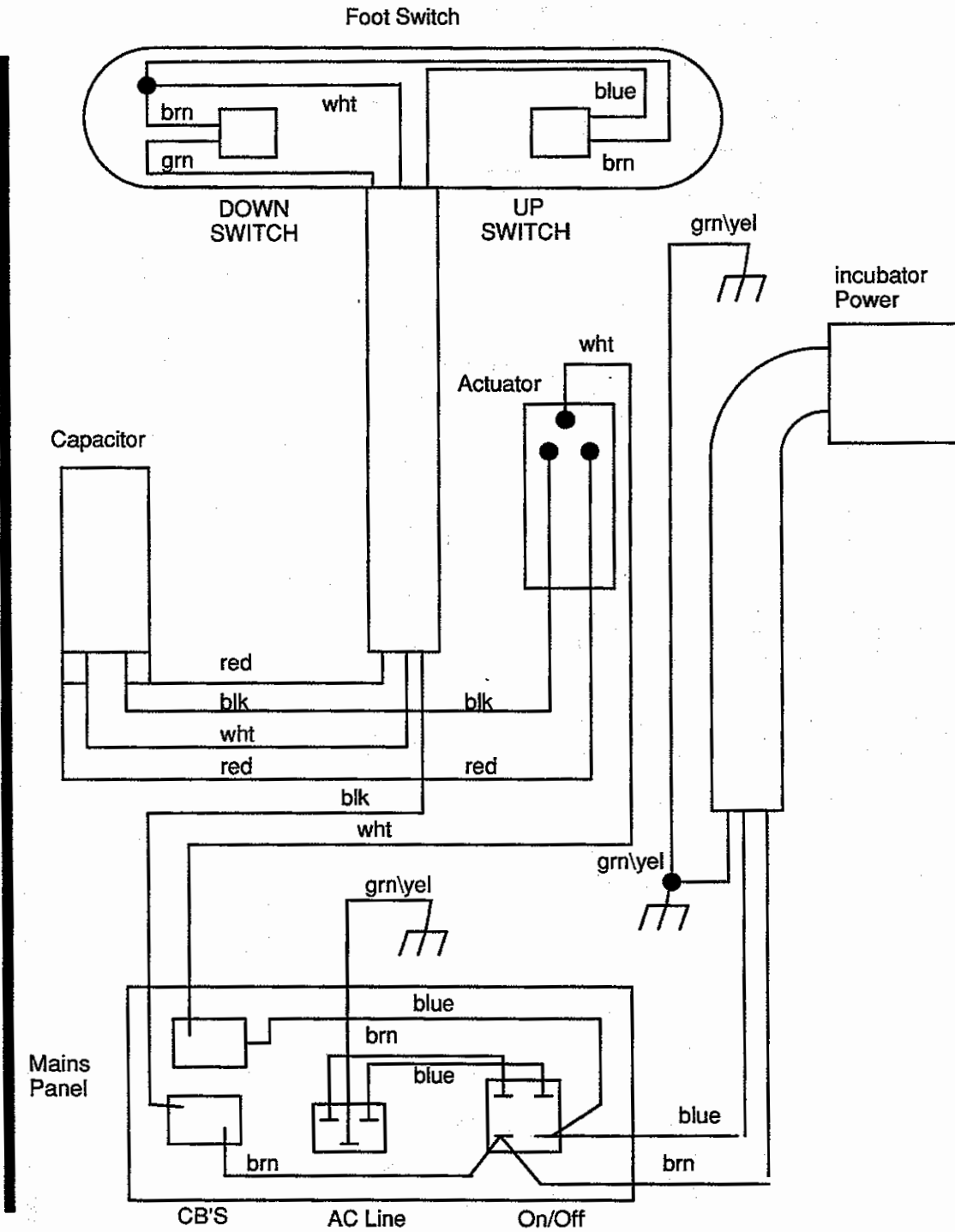

FIGURE 5.5 VHA STAND WIRING DIAGRAM-220/240V UNITS

Change 1

8. Remove the two nuts (49) holding the Incubator Power Cord Ground Lug and the Ground Lug from the Actuator wiring harness (Green/Yellow Wires) from the Stand. Remove the Cable Clamp (36) that attaches the Actuator wiring harness to the Stand.
9. Remove the two nuts (50) that hold the Actuator from beneath the Stand. Pull the Actuator straight out of the Stand.
10. To install the Actuator, first perform Steps 5 through 9 in reverse order.
11. Connect the unit to the ac line and then, while holding the actuator, extend the actuator to maximum. Temporarily install the Escutcheon on the actuator studs using two nuts (50). Carefully lower and guide the Escutcheon onto the six studs on the stand. Remove the nuts holding the actuator.
12. Install the platform (13) and secure it with 8 nuts (50).
13. Install the cable clamps (35) on the platform and replace the Incubator on the VHA Stand.

UP/DOWN SWITCH

Refer to Figure 6.14 for references in parentheses ().

1. Perform Steps 1 through 4 of the VHA Stand Procedure.
2. Remove the Red and White wires from the Capacitor. Remove the Black wire coming from the Up/Down Switch wiring harness from Circuit Breaker on the Mains Panel (Refer to Figure 5.4 for 120V Units or Figure 5.5 for 220V/240V Units).
3. Remove the four nuts (49) that hold the Switch Assembly to the Stand. Remove the Switch Assembly and wiring harness from the Stand.
4. Install the new Switch Assembly by performing Steps 2 and 3 in reverse order. Then perform Steps 11, 12 and 13 of the VHA Stand Actuator Procedure.

PHASE SHIFT CAPACITOR

Refer to Figure 6.14 for references in parentheses ().

1. Perform Steps 1 through 4 of the VHA Removal Procedure.
2. Remove the two Red, one Blue and one Black wires from the capacitor (refer to Figure 5.4 for 120V Units or Figure 5.5 for 220V/240V Units).
3. Remove the nuts (49) and strap (7) holding the Capacitor (4) in place.
4. Install the capacitor by performing Steps 2 and 3 in reverse order. Then perform Steps 11, 12 and 13 of the VHA Stand Actuator Procedure.

5.7.6 REASSEMBLY OF INNER COLUMN INTO OUTER COLUMN (REFER TO FIGURE 5.6)

CAUTION: Do not attempt to reassemble the Inner Column into the Outer Column without using the Gib Pins (Air-Shields Part No. 68 900 02). Improper assembly may cause damage to the Gibs.

1. If necessary, remove the inner column assembly from the outer column.
2. Use a screwdriver to push each Gib back and insert the Gib Pins into the slots (refer to Figure 3.9) to retain the Gibs.
3. Insert the Inner Column into the Outer Column until the four lower Gib Pins rest on the top surface of the Outer Column.
4. Remove the four lower Gib Pins. Push the Inner Column down into the Outer Column until the upper Gib Pins contact the top surface of the Outer Column. Remove the Gib Pins.
5. Continue to push the Inner Column down until the Gibs are below the two surfaces of the Outer Column.

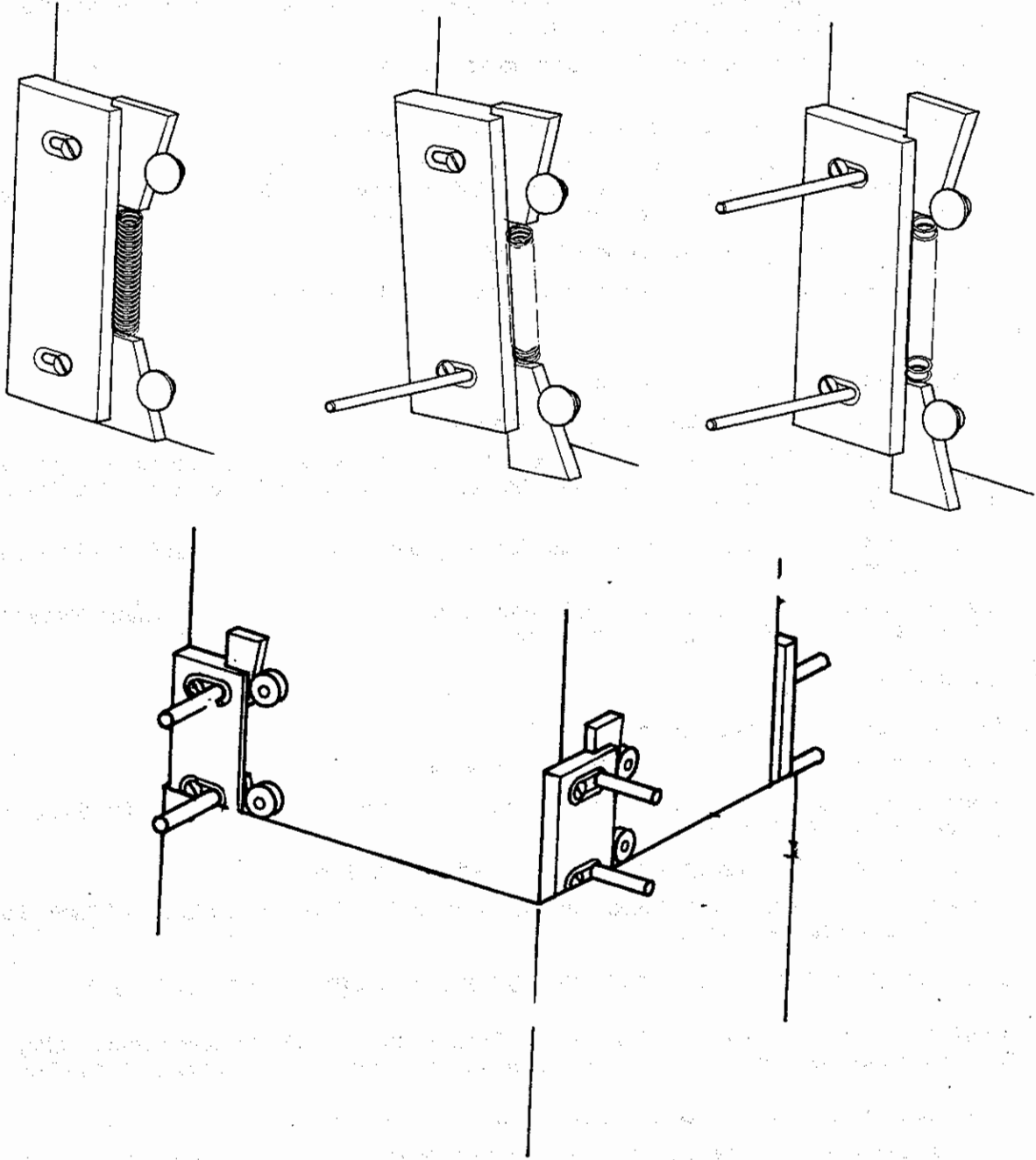

FIGURE 5.6 INSERTION OF GIB PINS

SECTION 6 PARTS LIST

6.1 GENERAL

This section provides parts lists for the Isolette® Infant Incubators, Models C500 QT® and C550 QT®. Part numbers of operator replaceable parts, accessories and single use items are provided below:

OPERATOR REPLACEABLE PARTS	PART NO.
AC LINE CORD 120V	17 AZ 100
AC LINE CORD 220V	17 AZ 200
AUXILIARY AIR TEMPERATURE PROBE	68 209 81
BABY TEMPERATURE PROBE (Model C550 QT® only)	68 209 70
INNER WALLS W/MTG KNOBS (Model C550 QT® only) (optional in C500 QT®)	68 500 40
MICROFILTER (Box of 4)	26 945 70
MATTRESS TILT BELLOWS	68 504 29
BELLOWS, BOTTOM PLATE	68 504 28
BELLOWS, TOP PLATE	68 504 32
WEIGHING HOOK (5" for Weighing Scale)	12 621 70
WEIGHING SLING	26 830 20
 ACCESSORIES	
CABINET STAND	68 416 30
RAIL SYSTEM FOR STANDARD CABINET STAND	68 407 70
SOLAIR™ TRANSPARENT HOOD WARMER	68 508 70
MICRO-LITE™ PHOTOTHERAPY SYSTEM	68 420 70
GUARD RAIL, MODEL C500/550 QT®	68 416 50
DEW-ETTE® INCUBATOR HUMIDIFIER	
English w/Remote (120V)	68 127 70
English w/o Remote (120V)	68 127 80
English w/Remote (220/240V)	68 127 73
English w/o Remote (220/240V)	68 127 83
German w/Remote (220/240V)	68 127 76
German w/o Remote (220/240V)	68 127 86
Spanish w/Remote (120V)	68 127 71
Spanish w/o Remote (120V)	68 127 81
Spanish w/Remote (220/240V)	68 127 74
Spanish w/o Remote (220/240V)	68 127 84
Italian w/Remote (220/240V)	68 127 77
Italian w/o Remote (220/240V)	68 127 87
French w/Remote (120V)	68 127 72
French w/o Remote (120V)	68 127 82
French w/Remote (220/240V)	68 127 75
French w/o Remote (220/240V)	68 127 85
Japanese w/Remote (100V)	68 127 78
Japanese w/o Remote (110V)	68 127 88

Change 2

DEW-ETTE® MOUNTING PLATE W/OXYGEN INLET

English	68 125 60
Spanish	68 125 61
French	68 125 62
German	68 125 63
Italian	68 125 64
Japanese	68 125 65

STERILIZER TANK 26 517 01

WEIGHING SCALE 26 830 70

■ OXYGEN CYLINDER SUPPORT 26 840 70

POST (2) /SWIVEL SHELVES (2) (Standard Cabinet Stand) 68 401 70

I.V. POLE STANDARD CABINET STAND 68 415 35

REMOTE ALARM MODULE (Requires I.V. Pole or Rail System for Mounting) 68 413 70

HIGH TEMPERATURE TEST PLUG

English	68 231 20
Spanish	68 231 21
French	68 231 22
German	68 231 23

WARM WEIGH® I20 SCALE AND REPLACEMENT PARTS

WARM WEIGH® INFANT SCALE, MODEL I20 03 320 70

MATTRESS, DISPOSABLE (10 per case) 67 903 86

MATTRESS TRAY SH82000000

CALIBRATED WEIGHT SET 03 310 15

5 kg WEIGHT 03 310 16

OPTIONAL VHA STAND AND ACCESSORIES

VHA STAND ASSY 68 415 70

CABINET MODULE 68 416 80

DOOR FOR CABINET MODULE 68 416 85

I.V. POLE 68 415 25

RAIL SYSTEM FOR VHA STAND 68 407 80

RAIL SYSTEM (STANDARD AND VHA STANDS) ACCESSORIES

MONITOR SHELF PACKAGE 68 408 00

ATHENA® MONITOR SHELF ASSY 68 408 15

ATHENA® MONITOR PAM KIT 68 408 70

UTILITY POLE ASSY 68 408 20

I.V. TREE ASSY 68 408 30

OVERHEAD RAIL 68 408 35

MODURA ASSY 68 408 45

STUB MOUNT ASSY 68 408 40

OXYGEN FLOWMETER KIT 68 408 50

AIR FLOW KIT 68 408 55

SUCTION KIT 68 408 60

BLENDER KIT 68 408 65

MICRO-LITE™ PIVOT ARM ASSY 68 423 80

Change 4

SINGLE USE ITEMS

ENTRY PORT SLEEVES (Case of 100)	26 920 70
ACCESS DOOR CUFFS DISPOSABLE (Case of 100)	68 120 70
MATTRESSES (Case of 10)	79 265 10
CRITTER COVERS® PROBE COVERS (Box of 100)	68 209 46
CRITTER COVERS® PROBE COVERS (Ctn of 600)	68 209 45
STORAGE COVERS (Pack of 50)	26 920 72
HUMIDITY INDICATOR CARDS (Pack of 5)	68 120 43
KLEENASEPTIC® CLEANSER (6 One-quart bottles per case w/one spray pump)	79 251 73
VAPASEPTIC® AIR SANITIZER (Case of 12)	79 250 71
PREMI-PROBE® 1, DISPOSABLE TEMP PROBE, (Box of 10)	68 209 20
PREMI-PROBE® 1, DISPOSABLE TEMP PROBE, (Ctn of 100)	68 209 30

Change 5

6.2 RECOMMENDED SPARE PARTS – QUANTITY OF 1 TO 5 UNITS

REPLACEMENT PART	QTY	PART NO.
ACCESS DOOR GASKET	2	68 120 01
ACCESS GROMMET	2	68 120 45
ACCESS CUFF	2	68 120 56
IRIS RING ASSEMBLY	2	68 120 76
TRIM STRIP	2	68 121 25
PLUNGER	2	68 121 45
STRICKER PLATE	2	68 121 55
IMPELLER	1	68 205 41
THERMISTOR ASSEMBLY	1	68 214 76
AIR FLOW SENSOR	1	68 214 81
MOTOR ASSEMBLY	1	68 230 20
ACCESS DOOR HINGE	2	68 510 05
ACCESS DOOR SPRING	2	68 510 10
ACCESS DOOR PIVOT	2	68 510 40
ACCES PANEL GASKET	1	68 512 10
PAWL LATCH KIT	2	68 902 96
MAIN PCB TESTED	1	68 908 40

Change 6

■ This page is intentionally left blank.

Change 6

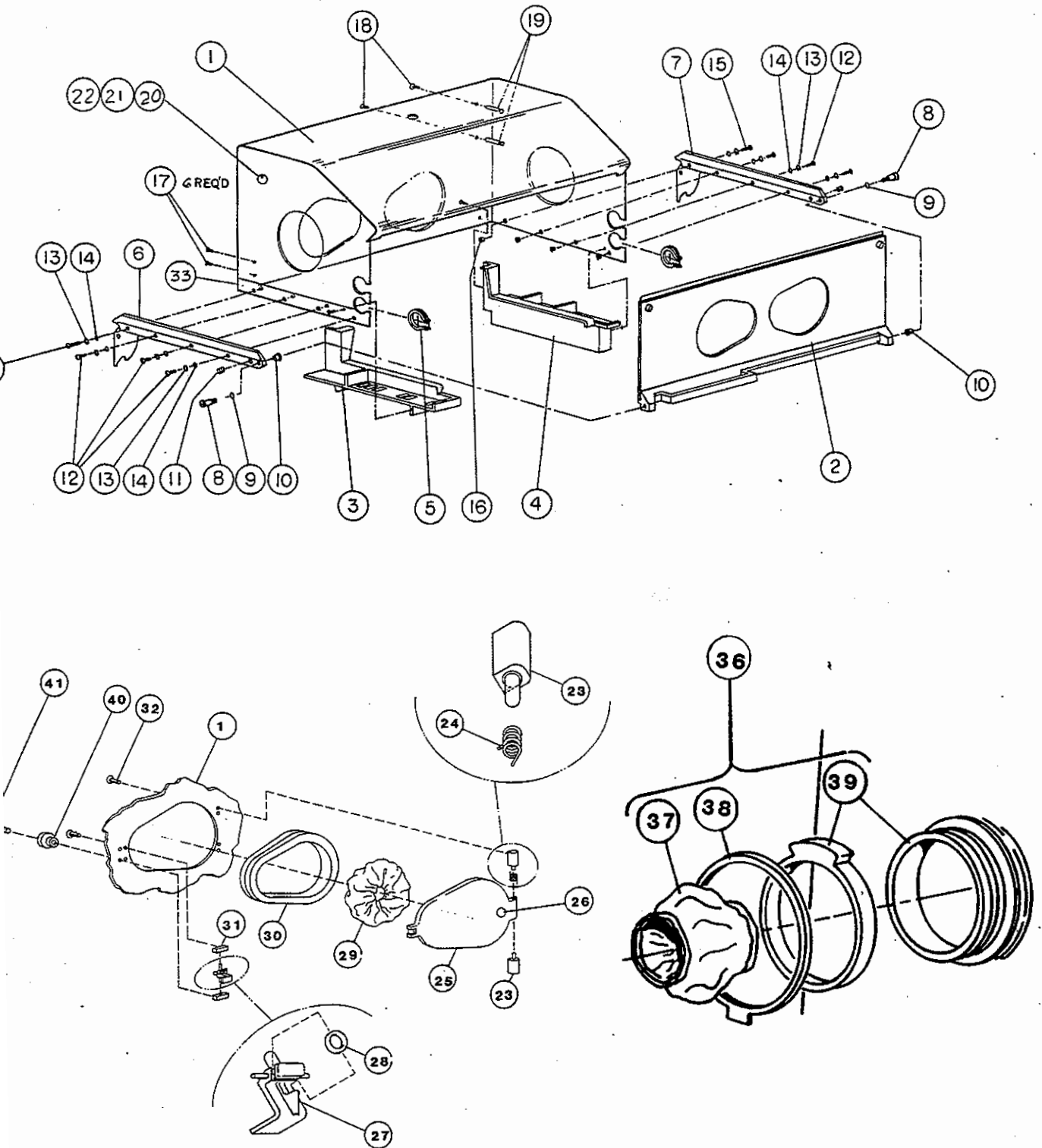

FIGURE 6.1 PARTS LOCATION DIAGRAM, HOOD ASSEMBLY

TABLE 6.1 HOOD ASSEMBLY, PARTS LIST

(Sheet 1 of 1)

ITEM NO.	REFERENCE DESIG.	DESCRIPTION	PART NUMBER
		HOOD ASSEMBLY, 2 ACCESS DOORS, 2 IRIS PORTS	68 505 72
		HOOD ASSEMBLY, 3 ACCESS DOORS, 1 IRIS PORT	68 505 71
1**		HOOD, INCUBATOR (ACRYLIC ONLY)	
		2 ACCESS DOORS, 2 IRIS PORTS (INCLUDES 3 & 4)	68 901 48
		3 ACCESS DOORS, 1 IRIS PORT (INCLUDES 3 & 4)	68 901 47
2		ACCESS PANEL (REFER TO TABLES 6.2 or 6.3))	68 159 90
3***		BAFFLE LEFT	68 156 34
4***		BAFFLE RIGHT	68 156 14
5		ACCESS GROMMET	68 120 45
6		HOOD MOUNT, LEFT SIDE	68 121 15
7		HOOD MOUNT, RIGHT SIDE	68 121 05
8*		SCREW, SHOULDER SLOTTED HEAD	68 121 30
9*		WASHER, NON-METALLIC, 3/8 ID	68 121 40
10*		BEARING FLANGE, 3/8 ID	68 121 35
11*		PLUNGER SPRING	68 121 45
12		SCREW, 10 - 32 X 5/8, LG, TR, PH SS	99 023 58
13		WASHER, NO. 10, LOCK INTER, SS	99 123 92
14		WASHER, NO. 10, FLAT SS 0.062 THK	99 123 62
15		SCREW, 10 - 32, 7/8 LG, TR, PH, SS	99 043 18
16		STUD, THREADED, 10 - 32	26 301 14
17		SCREW, 6 - 32 X 1/2, TR, PH, SS	99 023 63
18		SCREW, 6 - 32 X 3/4, TR, PH, SS	99 024 69
19		HUMIDITY CARD MOUNTING STUD	68 120 41
20		THREADED STUD, 10 - 32	26 301 14
21		COVER PLATE	26 651 22
22		SCREW, 10 - 32 X 1/4	99 040 51
23		HINGE PIVOT	68 510 05
24		TORSION SPRING	68 510 10
25		DOOR ASSEMBLY	68 902 85
26		BUMPER CLR POLYURETH, SELF ADHES	78 293 10
27		ACCESS DOOR LATCH ASSEMBLY, INCLUDES ITEM 28	68 902 97
28		O-RING, 3/8 DIA X 1/2 OD X 1/16 NPRN	99 160 54
29		ACCESS DOOR CUFF	68 120 56
30		ACCESS DOOR GASKET	68 120 01
31		LATCH PIVOT	68 510 40
32		SCREW, 6 - 32 X 3/8 FL PH SS	99 023 39
33		WHITE PLASTIC TRIM STRIP	68 147 00
34		REINFORCING DISK	68 156 03
35		TRIM STRIP, WHITE (NOT SHOWN) COVERS SCREWS OF ITEMS 6 & 7	68 121 25
36		IRIS PORT ASSEMBLY	68 120 74
37		IRIS PORT SLEEVE, REUSABLE	12 615 00
		DISPOSABLE	26 920 70
38		RETAINING RING	68 120 32
39		RING ASSEMBLY	68 120 76
40		SMALL RETAINER KNOB	68 156 62
41		SCREW, 6 - 32 X 1.12 TR PH SS NYLOCK	99 025 44
42		HEAT SHIELD ASSY (NOT SHOWN)(REAR)	68 113 16

*Not supplied with Hood Assembly - Must be ordered separately.

**Also order Quantity 2 of Item 35 - Trim Strip

***Baffle Replacement Kit includes both baffles - P/N 68 901 46

Change 4

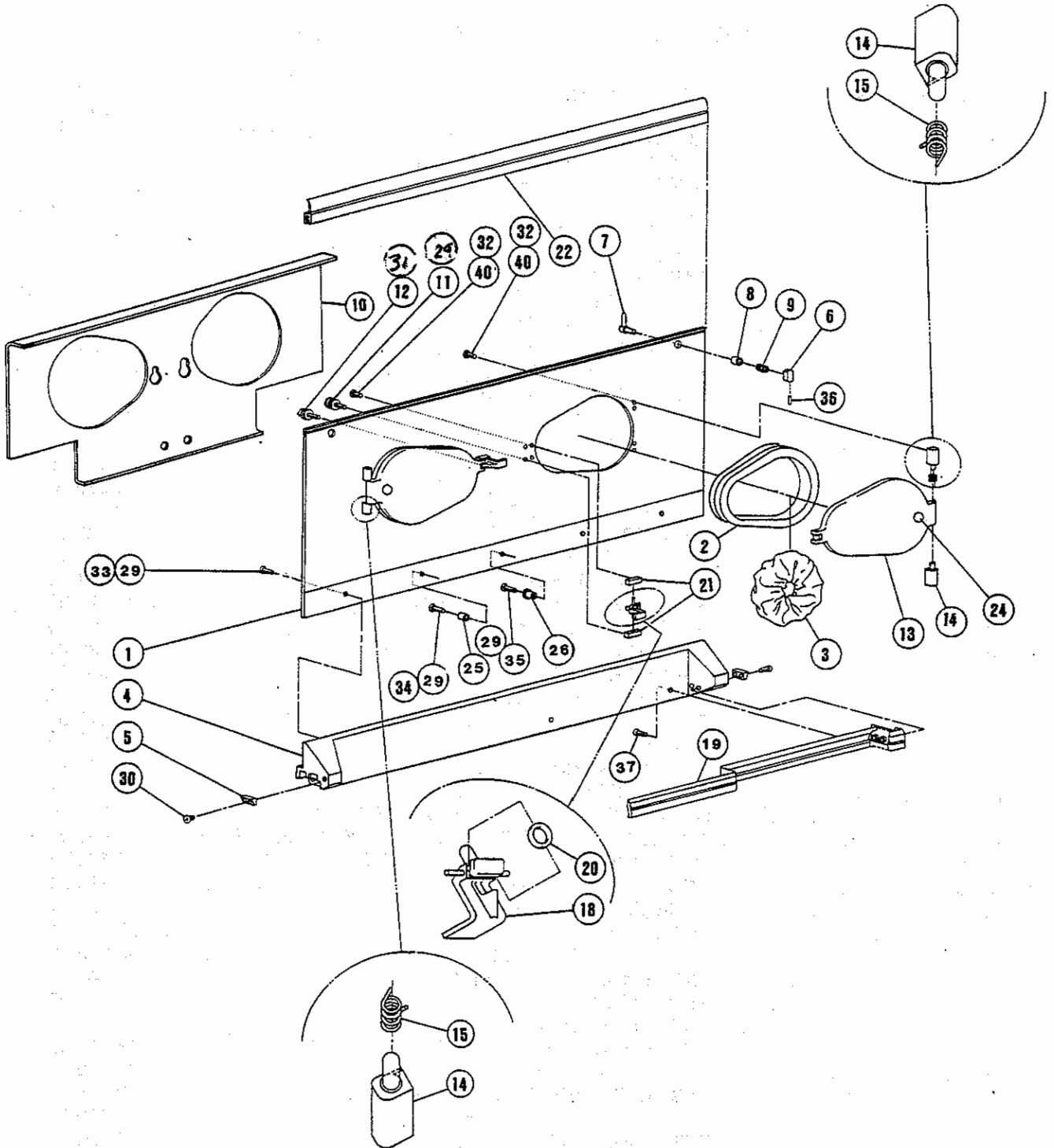

**FIGURE 6.2 PARTS LOCATION DIAGRAM, ACCESS PANEL ASSEMBLY UNITS
EQUIPPED WITH PNEUMATIC TILT**

Change 4

**TABLE 6.2 ACCESS PANEL ASSEMBLY, UNITS EQUIPPED WITH PNEUMATIC
TILT, PARTS LIST**
(Sheet 1 of 1)

ITEM NO.	REFERENCE DESIG.	DESCRIPTION	PART NUMBER
1		PANEL, ACCESS, REPLACEMENT KIT, (INCLUDES ITEMS 6,7,8,9, 26,35,36,38, 39 AND 41)	ENG 68 901 50
		SPN 68 901 51	
		FRN 68 901 52	
		GER 68 901 53	
		ITL 68 901 54	
2		GASKET, ACCESS DOOR, REUSABLE	68 120 03
3		CUFF, ACCESS DOOR	68 120 56
4		BEZEL, FRONT, ACCESS, PNL MTG	68 506 40
5		PLATE, STRIKER	68 121 55
6		REFER TO ITEM 16	
7		REFER TO ITEM 16	
8		REFER TO ITEM 16	
9		REFER TO ITEM 16	
10		HEAT SHIELD, FRONT	68 113 15
11		KNOB, RETAINER, LARGE	68 156 61
12		KNOB, RETAINER, SMALL	68 156 60
13		DOOR, ASSEMBLY	68 902 85
14		PIVOT, HINGE	68 510 05
15		SPRING, TORSION	68 510 10
16		PAWL LATCH REPLACEMENT KIT	68 902 96
17		NOT USED	
18		LATCH ASSY, ACCESS DOOR INCLUDES ITEM 20	68 510 26
19		FRONT BEZEL HANDLE	68 506 42
20		O RING, 3/8 ID x 1/2 OD x 1/16, NPRN	99 160 54
21		PIVOT, LATCH	68 510 40
22		STRIP, SEALING	68 512 10
23		NOT USED	
24		BUMPER, CLR POLYURETH, SELF ADH	78 293 10
25		SPACER, 1/2 OD X 0.166 ID X 3/8 LG	68 156 66
26		MATTRESS STOP GUIDE	68 504 43
27		NOT USED	
28		ADHESIVE, CYACRLT, LOC 404/EAST 910	AR
29		ADHESIVE, CLEAR 3M4693	AR
30		SCREW, 6-32 x 1/4 FL PH SS	99 023 94
31		SCREW, 6-32 x 1" TR PH SS, NYLOK	99 025 23
32		SCREW, 6-32 x 3/8 FL PH SS	99 023 64
33		SCREW, 8-32 x 1/2 TR PH SS	99 031 99
34		SCREW, 8-32 x 7/8 FL PH SS	99 033 15
35		SCREW, 8 - 32 X 7/8 TR PH SS	99 033 19
36		REFER TO ITEM 16	
37		SCREW, NO. 6 X 3/8" FL PH SS	99 023 39
38		PINK QT/ ANIMALS LABEL (NOT SHOWN)	68 512 36
39		WARNING; INFANT SAFETY LABEL -ENG (NOT SHOWN)	68 501 20
		SPN 68 501 21	
		FRN 68 501 22	
		GER 68 501 23	
		ITL 68 501 24	
40		ADHESIVE, CLR, ELASTOMERC3M4693	99 902 53
41		PATENT PENDING LABEL	68 512 13

Change 7

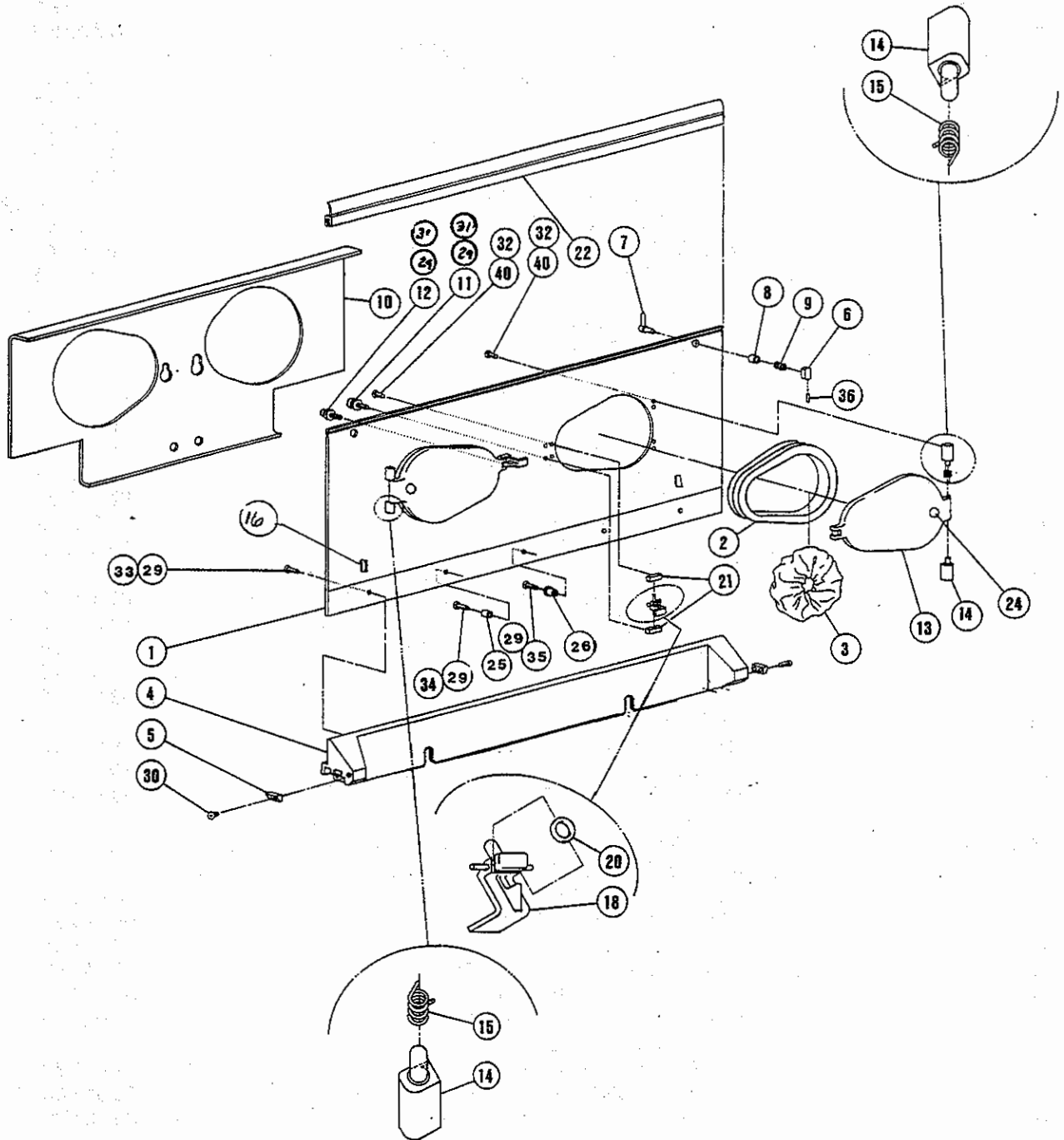

**FIGURE 6.3 PARTS LOCATION DIAGRAM, ACCESS PANEL ASSEMBLY UNITS
EQUIPPED WITH MANUAL TILT**

Change 6

**TABLE 6.3 ACCESS PANEL ASSEMBLY, UNITS EQUIPPED WITH MANUAL TILT,
PARTS LIST**
(Sheet 1 of 1)

ITEM NO.	REFERENCE DESIG.	DESCRIPTION	PART NUMBER
1		PANEL, ACCESS, REPLACEMENT KIT, (INCLUDES ITEMS 6,7,8,9,26,35,36,38, 39 AND 41) ENG	68 901 50
		SPN	68 901 51
		FRN	68 901 52
		GER	68 901 53
		ITL	68 901 54
2		GASKET, ACCESS DOOR, REUSABLE	68 120 03
3		CUFF, ACCESS DOOR	68 120 56
4		STRIP, ACCESS PANEL MOUNTING, FRONT	68 121 24
5		PLATE, STRIKER	68 121 55
6		REFER TO ITEM 37	
7		REFER TO ITEM 37	
8		REFER TO ITEM 37	
9		REFER TO ITEM 37	
10		HEAT SHIELD, FRONT	68 113 15
11		KNOB, RETAINER, LARGE	68 156 61
12		KNOB, RETAINER, SMALL	68 156 60
13		DOOR, ASSEMBLY	68 902 85
14		PIVOT, HINGE	68 510 05
15		SPRING, TORSION	68 510 10
16		MATTRESS TRAY STOPS	68 114 43
17		NOT USED	
18		LATCH ASSY, ACCESS DOOR, INCLUDES ITEM 20	68 510 26
19		NOT USED	
20		O RING, 3/8 ID x 1/2 OD x 1/16, NPRN	99 160 54
21		PIVOT, LATCH	68 510 40
22		STRIP, SEALING	68 512 10
23		NOT USED	
24		BUMPER, CLR POLYURETH, SELF ADH	78 293 10
25		SPACER, 1/2 OD X 0.166 ID X 3/8 LG	68 156 66
26		MATTRESS STOP GUIDE	68 504 43
27		NOT USED	
28		ADHESIVE, CYACRLT, LOC 404/EAST 910	AR
29		ADHESIVE, CLEAR 3M4693	AR
30		SCREW, 6-32 x 1/4 FL PH SS	99 023 94
31		SCREWM 6-32 x 1" TR PH SS NYLOK	99 025 23
32		SCREW, 6-32 x 3/8 FL PH SS	99 023 64
33		SCREW, 8-32 x 1/2 TR PH SS	99 031 99
34		SCREW, 8-32 x 7/8 FL PH SS	99 033 15
35		SCREW, 8 - 32 X 7/8 TR PH SS	99 033 19
36		REFER TO ITEM 37	
37		PAWL LATCH REPLACEMENT KIT	68 902 96
38		PINK QT/ ANIMALS LABEL	68 512 36
39		WARNING; INFANT SAFETY LABEL-ENG	68 501 20
		SPN	68 501 21
		FRN	68 501 22
		GER	68 501 23
		ITL	68 501 24
40		ADHESIVE, CLR, ELASTOMERC3M4693	99 902 53
41		PATENT PENDING LABEL	68 512 13

Change 7

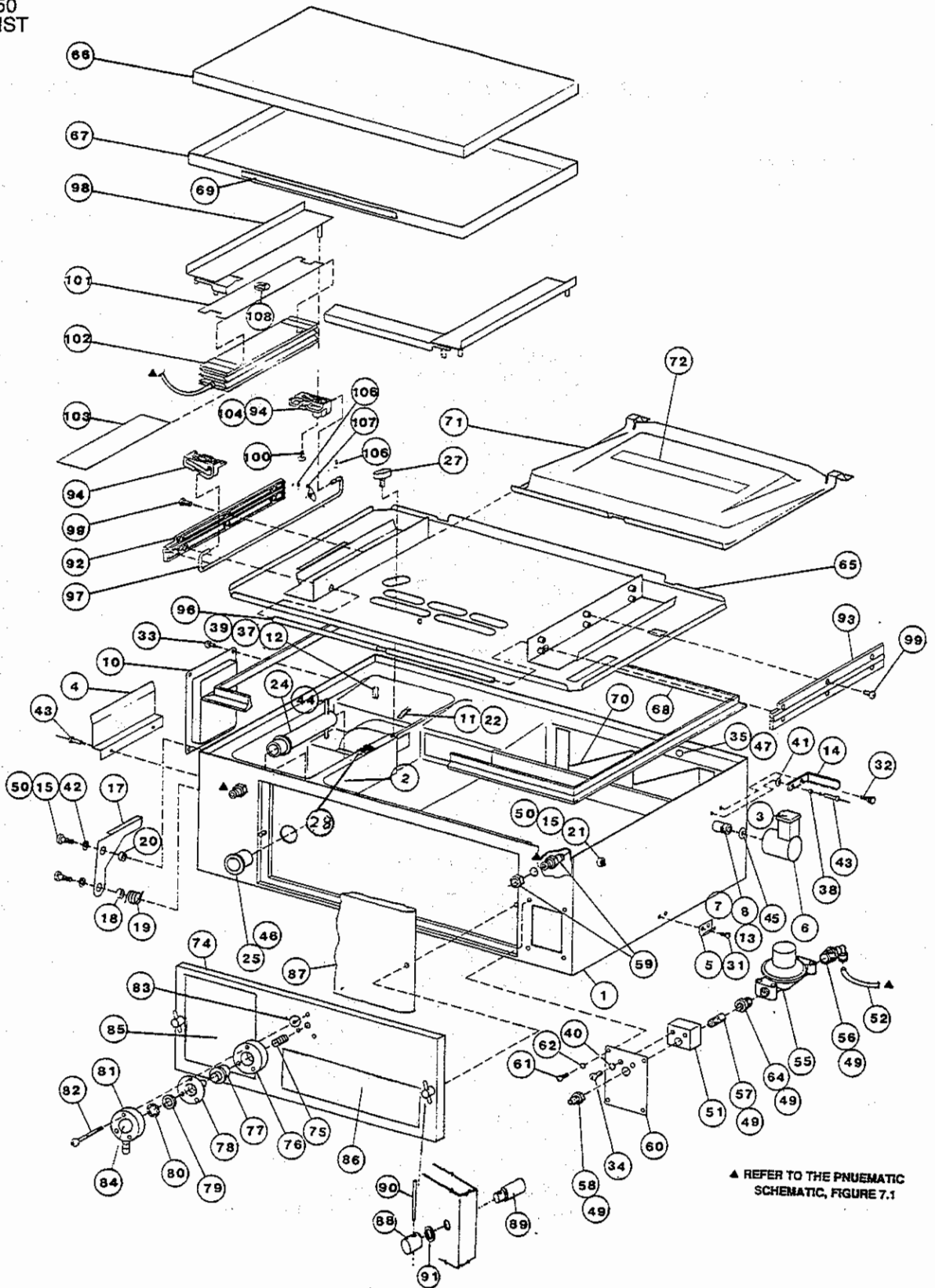

FIGURE 6.4 PARTS LOCATION DIAGRAM, SHELL AND PNEUMATIC TILT DECK ASSEMBLY

Change 7

TABLE 6.4 SHELL AND PNEUMATIC TILT DECK ASSEMBLY, PARTS LIST

(Sheet 1 of 4)

ITEM NO.	REFERENCE DESIG.	DESCRIPTION	PART NUMBER
1		SHELL	68 507 00
2		CASTING	26 100 30
3		FILLER PIPE CAP	12 209 01
4		POWER CORD DUCT	68 507 15
5		LATCH HOOK	24 144 01
6		HUMIDITY CHAMBER FILL SPOUT	26 200 02
7		SEALING WASHER	26 204 02
8		SEALING PIVOT NUT	26 205 00
9		NOT USED	
10		RECESSED OUTLET PANEL	68 500 15
		RECESSED OUTLET PANEL LABEL - C500, 120V ENG	68 500 20
		RECESSED OUTLET PANEL LABEL - C500, 120V SPN	68 500 21
		RECESSED OUTLET PANEL LABEL - C500, 120V FRN	68 500 22
		RECESSED OUTLET PANEL LABEL - C500, 220V GER	68 500 23
		RECESSED OUTLET PANEL LABEL - C500, 220/240V ENG	68 500 24
		RECESSED OUTLET PANEL LABEL - C500, 220/240V ITL	68 500 25
		RECESSED OUTLET PANEL LABEL - C500, 220/240V SPN	68 500 27
		RECESSED OUTLET PANEL LABEL - C500, 220/240V FRN	68 500 28
		RECESSED OUTLET PANEL LABEL - C550, 120V ENG	68 500 30
		RECESSED OUTLET PANEL LABEL - C550, 120V SPN	68 500 31
		RECESSED OUTLET PANEL LABEL - C550, 120V FRN	68 500 32
		RECESSED OUTLET PANEL LABEL - C550, 220V GER	68 500 33
		RECESSED OUTLET PANEL LABEL - C550, 220/240V ENG	68 500 34
		RECESSED OUTLET PANEL LABEL - C550, 220/240V ITL	68 500 35
		RECESSED OUTLET PANEL LABEL - C550, 220/240V SPN	68 500 37
		RECESSED OUTLET PANEL LABEL - C550, 220/240V FRN	68 500 38
11		GROUNDING SPRING	68 400 27
12		RAMP LATCH	68 110 42
13		HUMIDITY CHAMBER PIPE	68 110 43
14		FILL SPOUT STOP	68 110 50
15		SLOTTED SHOULDER SCREW	68 110 52
16		NOT USED	
17		LATCH HANDLE	68 110 55
18		SPACER NON-METALLIC	68 110 56
19		TORSION SPRING	68 110 57
20		SPACER NON - METALLIC	68 110 58
21		SPACER NON-METALLIC	68 110 59
22		HEX NUT, 6-32 KEPS	99 105 34
23		NOT USED	
24		CROSS FEED PIPE	68 112 05
25		FILTER GROMMET	68 112 15
26		NOT USED	
27		DECK RETAINING KNOB REPL KIT	68 901 22
28		GASKET	68 232 37

Change 7

TABLE 6.4 SHELL AND PNEUMATIC TILTDECK ASSEMBLY, PARTS LIST

(Sheet 2 of 4)

ITEM NO.	REFERENCE DESIG.	DESCRIPTION	PART NUMBER
29		NOT USED	
30		NOT USED	
31		SCREW, 4 - 40 X 5/16 FL PH SS	99 010 77
32		THUMB SCREW, 4 - 40 X 1/4	99 010 63
33		SCREW, 4 - 40 X 5/16 TR PH SS	99 010 76
34		SCREW, 10 - 32 X 1/2 TR PH SS	99 042 01
35		SCREW, 8 - 32 X 3/8 RD PH SS	99 031 37
36		NOT USED	
37		HEX NUT, 8 - 32 SS	99 106 01
38		SPACER, 0.250 OD X 0.40 ID X 0.25 THK	99 121 96
39		LOCK WASHER, #8	99 122 95
40		LOCK WASHER #10	99 124 16
41		WASHER, 0.560 OD X 0.25 ID PLASTIC	99 125 57
42		WASHER, 0.38 OD X 0.62 ID	99 126 70
43		POP RIVET, 1/8 D LG FLANGE	99 131 70
44		PIN, 1/8 DIA X 1 1/2 LG SS	99 143 96
45		O-RING 5/8 X 3/4 X 1/16	99 161 04
46		DOW CORNING LUBE #111	AR
47		WHITE RTV COMPOUND	AR
48		NOT USED	
49		TEFLON PIPE SEALANT	AR
50		LOCTITE #222	AR
51		AIR SUPPLY MANIFOLD	68 504 33
52		CLEAR TUBING 20" LONG 0.250 OD (REFER TO THE PNEUMATIC SCHEMATIC FIGURE 7.1)	68 505 11
53		BLUE TUBING 22" LONG 0.250 OD (REFER TO THE PNEUMATIC SCHEMATIC FIGURE 7.1)	68 505 21
54		RED TUBING 37" LONG 0.250 OD (REFER TO THE PNEUMATIC SCHEMATIC FIGURE 7.1)	68 505 31
55		REGULATOR, 2.1 PSIG PRESET	68 504 49
56		TUBING FITTING, MALE ELBOW	68 504 01
57		MUFFLER/FILTER ELEMENT, 1/8 NPT	68 504 45
58		AIR-IN VALVE, MALE DISS	78 435 26
59		TUBING FITTING, BLKHD UNION	68 504 19
60		REGULATOR MOUNTING PLATE	68 507 10
61		SCREW, 6 - 32 X 3/8 TR PH SS	99 023 31
62		LOCK WASHER SP #6	99 122 16
63		TIE WRAPS FOR TUBING (NOT SHOWN)	12 995 00
64		REDUCER BUSHING, 1/4 NPT X 1/8 FNPT	68 504 09
65		MAIN DECK	68 504 40
66		MATTRESS	68 142 71

TABLE 6.4 SHELL AND PNEUMATIC TILT DECK ASSEMBLY, PARTS LIST

(Sheet 3 of 4)

ITEM NO.	REFERENCE DESIG.	DESCRIPTION	PART NUMBER
67		MATTRESS TRAY ASSY ENG (INCLUDES ITEM 69)	68 901 40
		MATTRESS TRAY ASSY SPN	68 901 41
		MATTRESS TRAY ASSY FRN	68 901 42
		MATTRESS TRAY ASSY GER	68 901 43
		MATTRESS TRAY ASSY ITL	68 901 44
68		HOOD GASKET	12 216 00
69		MATTRESS TRAY WARNING LABEL ENG	68 160 30
		MATTRESS TRAY WARNING LABEL SPN	68 160 31
		MATTRESS TRAY WARNING LABEL FRN	68 160 32
		MATTRESS TRAY WARNING LABEL GER	68 160 33
		MATTRESS TRAY WARNING LABEL ITL	68 160 34
70		HUMIDITY BAFFLE	26 101 02
71		PLENUM ASSEMBLY (INCLUDES ITEM 72)	68 901 21
72		PLENUM LABEL	68 142 26
73		NOT USED	
74		FILTER COVER ASSEMBLY, ENG (INCLUDES ITEM 75 THRU 88)	68 507 40
		FILTER COVER ASSEMBLY, SPN (INCLUDES ITEM 75 THRU 88)	68 507 41
		FILTER COVER ASSEMBLY, FRN (INCLUDES ITEM 75 THRU 88)	68 507 42
		FILTER COVER ASSEMBLY, GER (INCLUDES ITEM 75 THRU 88)	68 507 43
		FILTER COVER ASSEMBLY, ITL (INCLUDES ITEM 75 THRU 88)	68 507 44
75		COMPRESSION SPRING	68 130 65
76		CYLINDER	68 130 55
77		FILTER CARTRIDGE	68 130 67
78		DIAPHRAGM	68 130 57
79		NON-METALLIC WASHER	68 130 51
80		RETAINING RING, WAL 5105-62 SS	99 182 93
81		CAP	68 130 60
82		SCREW, 6- 32 X 1.75" OV PH SS	99 026 18
83		NON-METALLIC WASHER	68 130 52
84		OXYGEN LIMITER LABEL, ENG	68 133 35
		OXYGEN LIMITER LABEL, SPN	68 133 36
		OXYGEN LIMITER LABEL, FRN	68 133 37
		OXYGEN LIMITER LABEL, GER	68 133 38
		OXYGEN LIMITER LABEL, ITL	68 133 34
85		OXYGEN CONCENTRATION LABEL, ENG	68 133 10
		OXYGEN CONCENTRATION LABEL, SPN	68 133 11
		OXYGEN CONCENTRATION LABEL, FRN	68 133 12
		OXYGEN CONCENTRATION LABEL, GER	68 133 13
		OXYGEN CONCENTRATION LABEL, ITL	68 133 15

TABLE 6.4 SHELL AND PNEUMATIC TILT DECK ASSEMBLY, PARTS LIST

(Sheet 4 of 4)

ITEM NO.	REFERENCE DESIG.	DESCRIPTION	PART NUMBER
86		FILTER COVER LABEL, ENG	26 330 60
		FILTER COVER LABEL, SPN	26 330 61
		FILTER COVER LABEL, FRN	26 330 62
		FILTER COVER LABEL, GER	26 330 63
		FILTER COVER LABEL, ITL	26 330 64
87		AIR FILTER (BOX OF 4)	26 945 70
88		FILTER COVER KNOB	68 130 30
89		FILTER COVER KNOB SHAFT	68 130 35
90		FILTER COVER KNOB HANDLE	68 130 40
91		WASHER, 0.38 ID X 0.62 OD X 0.15 THK NYLON	99 126 11
92		RIGHT DECK RAIL	68 504 30
93		LEFT DECK RAIL	68 504 37
94		RIGHT DECK RETAINER (WITHOUT PIN)	68 504 34
95		LEFT DECK RETAINER (WITHOUT PIN)	68 504 35
96		PLENUM ROD	68 504 31
97		MATTRESS TRAY STABILIZER BAR	68 504 36
98		TRAY SUPPORT	68 504 38
99		SCREW, 4 - 40 X 1/4" TR PH SS NYLOC	99 010 67
100		SCREW, 4 - 40 X 1/2" TR PH SS NYLOC	99 011 63
101		BELLOWS TOP PLATE (INCLUDES LABEL, ITEM 108)	68 901 20
102		BELLOWS	68 504 29
103		BELLOWS BOTTOM PLATE	68 504 28
104		STABILIZER BAR RETAINER RIGHT-HAND WITH PIN	68 504 65
105		STABILIZER BAR RETAINER LEFT-HAND WITH PIN (NOT SHOWN)	68 504 35
106		RETAINING RING	99 181 47
107		LOCK-UP CLIP	68 504 44
108		LABEL, MANUAL REFERENCE SYMBOL (INCLUDED WITH ITEM 101)	68 160 05

Change 2

(This page is intentionally left blank.)

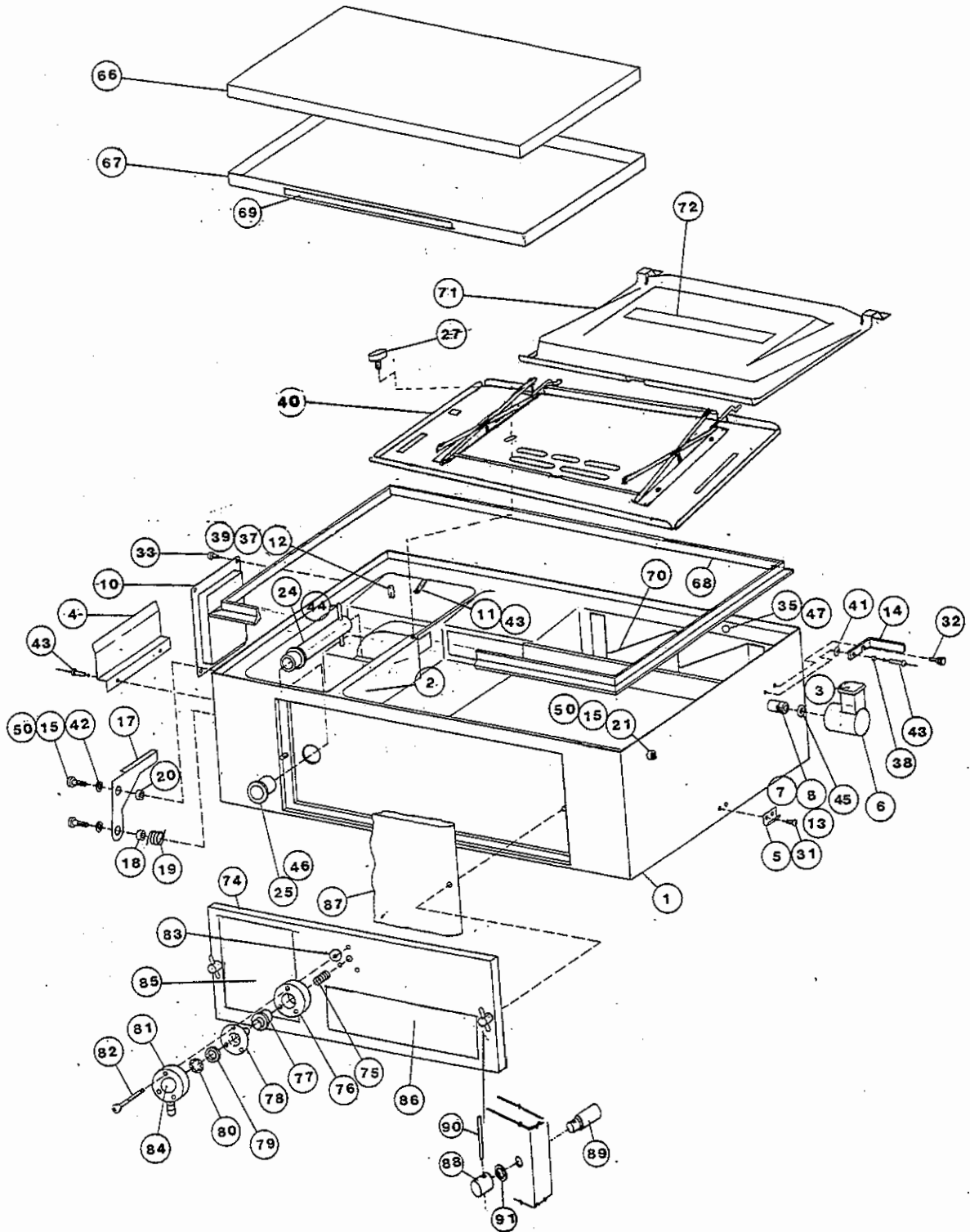

FIGURE 6.5 PARTS LOCATION DIAGRAM, SHELL AND MANUAL TILT DECK ASSEMBLY

TABLE 6.5 SHELL AND MANUAL TILT DECK ASSEMBLY, PARTS LIST

(Sheet 1 of 3)

ITEM NO.	REFERENCE DESIG.	DESCRIPTION	PART NUMBER
1		SHELL	68 507 00
2		CASTING	26 100 30
3		FILLER PIPE CAP	12 209 01
4		POWER CORD DUCT	68 507 15
5		LATCH HOOK	24 144 01
6		HUMIDITY CHAMBER FILL SPOUT	26 200 02
7		SEALING WASHER	26 204 02
8		SEALING PIVOT NUT	26 205 00
9		NOT USED	
10		RECESSED OUTLET PANEL	68 500 15
		RECESSED OUTLET PANEL LABEL – C500, 120V ENG	68 500 20
		RECESSED OUTLET PANEL LABEL – C500, 120V SPN	68 500 21
		RECESSED OUTLET PANEL LABEL – C500, 120V FRN	68 500 22
		RECESSED OUTLET PANEL LABEL – C500, 220V GER	68 500 23
		RECESSED OUTLET PANEL LABEL – C500, 220/240V ENG	68 500 24
		RECESSED OUTLET PANEL LABEL – C500, 220/240V ITL	68 500 25
		RECESSED OUTLET PANEL LABEL – C500, 220/240V SPN	68 500 27
		RECESSED OUTLET PANEL LABEL – C500, 220/240V FRN	68 500 28
		RECESSED OUTLET PANEL LABEL – C550, 120V ENG	68 500 30
		RECESSED OUTLET PANEL LABEL – C550, 120V SPN	68 500 31
		RECESSED OUTLET PANEL LABEL – C550, 120V FRN	68 500 32
		RECESSED OUTLET PANEL LABEL – C550, 220V GER	68 500 33
		RECESSED OUTLET PANEL LABEL – C550, 220/240V ENG	68 500 34
		RECESSED OUTLET PANEL LABEL – C550, 220/240V ITL	68 500 35
		RECESSED OUTLET PANEL LABEL – C550, 220/240V SPN	68 500 37
		RECESSED OUTLET PANEL LABEL – C550, 220/240V FRN	68 500 38
11		LEAF SPRING	68 110 41
12		RAMP LATCH	68 110 42
13		HUMIDITY CHAMBER PIPE	68 110 43
14		FILL SPOUT STOP	68 110 50
15		SLOTTED SHOULDER SCREW	68 110 52
16		NOT USED	
17		LATCH HANDLE	68 110 55
18		SPACER NON-METALLIC	68 110 56
19		TORSION SPRING	68 110 57
20		SPACER NON – METALLIC	68 110 58
21		SPACER NON-METALLIC	68 110 59
22		NOT USED	
23		NOT USED	
24		CROSS FEED PIPE	68 112 05
25		FILTER GROMMET	68 112 15
26		NOT USED	
27		DECK RETAINING KNOB REPL KIT	68 901 22
28		NOT USED	

TABLE 6.5 SHELL AND MANUAL TILT DECK ASSEMBLY, PARTS LIST

(Sheet 2 of 3)

ITEM NO.	REFERENCE DESIG.	DESCRIPTION	PART NUMBER
29		NOT USED	
30		NOT USED	
31		SCREW, 4 - 40 X 5/16 FL PH SS	99 010 77
32		THUMB SCREW, 4 - 40 X 1/4	99 010 63
33		SCREW, 4 - 40 X 5/16 TR PH SS	99 010 76
34		NOT USED	
35		SCREW, 8 - 32 X 3/8 RD PH SS	99 031 37
36		NOT USED	
37		HEX NUT, 8 - 32 SS	99 106 01
38		SPACER, 0.250 OD X 0.40 ID X 0.25 THK	99 121 96
39		LOCK WASHER, #8	99 122 95
40		MAIN DECK MANUAL TILT (REFER TO TABLE 6.6)	
41		WASHER, 0.560 OD X 0.25 ID PLASTIC	99 125 57
42		WASHER, 0.38 OD X 0.62 ID	99 126 70
43		POP RIVET, 1/8 D LG FLANGE	99 131 70
44		PIN, 1/8 DIA X 1 1/2 LG SS	99 143 96
45		O-RING 5/8 X 3/4 X 1/16	99 161 04
46		DOW CORNING LUBE #111	AR
47		WHITE RTV COMPOUND	AR
48		NOT USED	
49		NOT USED	
50		LOCTITE #222	AR
51		NOT USED	
52		NOT USED	
53		NOT USED	
54		NOT USED	
55		NOT USED	
56		NOT USED	
63		NOT USED	
64		REDUCER BUSHING, 1/4 NPT X 1/8 FNPT	68 504 09
65		NOT USED	
66		MATTRESS	68 142 71
67		MATTRESS TRAY ASSY ENG (INCLUDES ITEM 69)	68 901 40
		MATTRESS TRAY ASSY SPN	68 901 41
		MATTRESS TRAY ASSY FRN	68 901 42
		MATTRESS TRAY ASSY GER	68 901 43
		MATTRESS TRAY ASSY ITL	68 901 44
68		HOOD GASKET	12 216 00
69		MATTRESS TRAY WARNING LABEL ENG	68 160 30
69		MATTRESS TRAY WARNING LABEL SPN	68 160 31
69		MATTRESS TRAY WARNING LABEL FRN	68 160 32
69		MATTRESS TRAY WARNING LABEL GER	68 160 33
69		MATTRESS TRAY WARNING LABEL ITL	68 160 34

TABLE 6.5 SHELL AND MANUAL TILT DECK ASSEMBLY, PARTS LIST

(Sheet 3 of 3)

ITEM NO.	REFERENCE DESIG.	DESCRIPTION	PART NUMBER
70		HUMIDITY BAFFLE	26 101 02
71		PLENUM ASSEMBLY (INCLUDES ITEM 72)	68 901 21
72		PLENUM LABEL	68 141 26
73		NOT USED	
74		FILTER COVER ASSEMBLY, ENG (INCLUDES ITEM 75 THRU 88)	68 507 40
		FILTER COVER ASSEMBLY, SPN (INCLUDES ITEM 75 THRU 88)	68 507 41
		FILTER COVER ASSEMBLY, FRN (INCLUDES ITEM 75 THRU 88)	68 507 42
		FILTER COVER ASSEMBLY, GER (INCLUDES ITEM 75 THRU 88)	68 507 43
		FILTER COVER ASSEMBLY, ITL (INCLUDES ITEM 75 THRU 88)	68 507 44
75		COMPRESSION SPRING	68 130 65
76		CYLINDER ... 68 130 55	
77		FILTER CARTRIDGE	68 130 67
78		DIAPHRAGM	68 130 57
79		NON-METALLIC WASHER	68 130 51
80		RETAINING RING, WAL 5105-62 SS	99 182 93
81		CAP	68 130 60
82		SCREW, 6- 32 X 1.75" OV PH SS	99 026 18
83		NON-METALLIC WASHER	68 130 52
84		OXYGEN LIMITER LABEL, ENG	68 133 35
		OXYGEN LIMITER LABEL, SPN	68 133 36
		OXYGEN LIMITER LABEL, FRN	68 133 37
		OXYGEN LIMITER LABEL, GER	68 133 38
		OXYGEN LIMITER LABEL, ITL	68 133 34
85		OXYGEN CONCENTRATION LABEL, ENG	68 133 10
		OXYGEN CONCENTRATION LABEL, SPN	68 133 11
		OXYGEN CONCENTRATION LABEL, FRN	68 133 12
		OXYGEN CONCENTRATION LABEL, GER	68 133 13
		OXYGEN CONCENTRATION LABEL, ITL	68 133 15
86		FILTER COVER LABEL, ENG	26 330 60
		FILTER COVER LABEL, SPN	26 330 61
		FILTER COVER LABEL, FRN	26 330 62
		FILTER COVER LABEL, GER	26 330 63
		FILTER COVER LABEL, ITL	26 330 64
87		AIR FILTER (BOX OF 4)	26 945 70
88		FILTER COVER KNOB	68 130 30
89		FILTER COVER KNOB SHAFT	68 130 35
90		FILTER COVER KNOB HANDLE	68 130 40
91		WASHER, 0.38 ID X 0.62 OD X 0.15 THK NYLON	99 126 11

Change 2

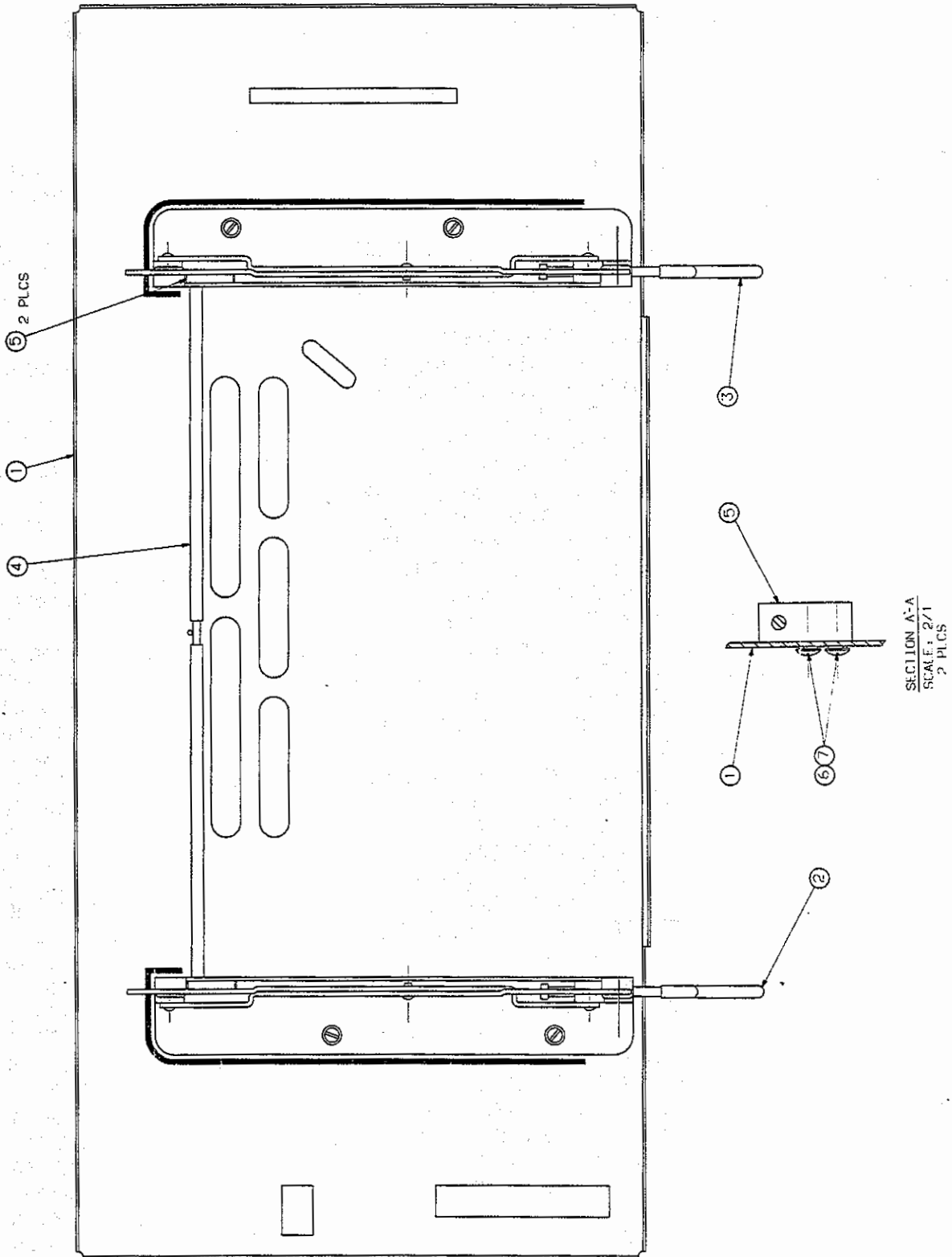

FIGURE 6.6 PARTS LOCATION DIAGRAM, MANUAL TILT DECK ASSEMBLY

TABLE 6.6 MANUAL TILT DECK ASSEMBLY, PARTS LIST

(Sheet 1 of 1)

ITEM NO.	REFERENCE DESIG.	DESCRIPTION	PART NUMBER
1		MAIN DECK	68 504 41
2		ELEVATOR ASSEMBLY, LEFT HAND, ENG	68 907 06
		ELEVATOR ASSEMBLY, LEFT HAND, SPN	68 907 07
		ELEVATOR ASSEMBLY, LEFT HAND, FRN	68 907 08
		ELEVATOR ASSEMBLY, LEFT HAND, GER	68 907 09
		ELEVATOR ASSEMBLY, LEFT HAND, ITL	68 907 10
3		ELEVATOR ASSEMBLY, RIGHT HAND,ENG	68 907 00
		ELEVATOR ASSEMBLY, RIGHT HAND, SPN	68 907 01
		ELEVATOR ASSEMBLY, RIGHT HAND, FRN	68 907 02
		ELEVATOR ASSEMBLY, RIGHT HAND,GER	68 907 03
		ELEVATOR ASSEMBLY, RIGHT HAND, ITL	68 907 04
4		PLENUM SHAFT	68 141 36
5		PLENUM PIVOT ROD	68 521 45
6		SCREW, 6 - 32 X 5/16 TR PH SS	99 022 98
7		LOCK WASHER NO. 6 SP SS	99 122 16

Change 1

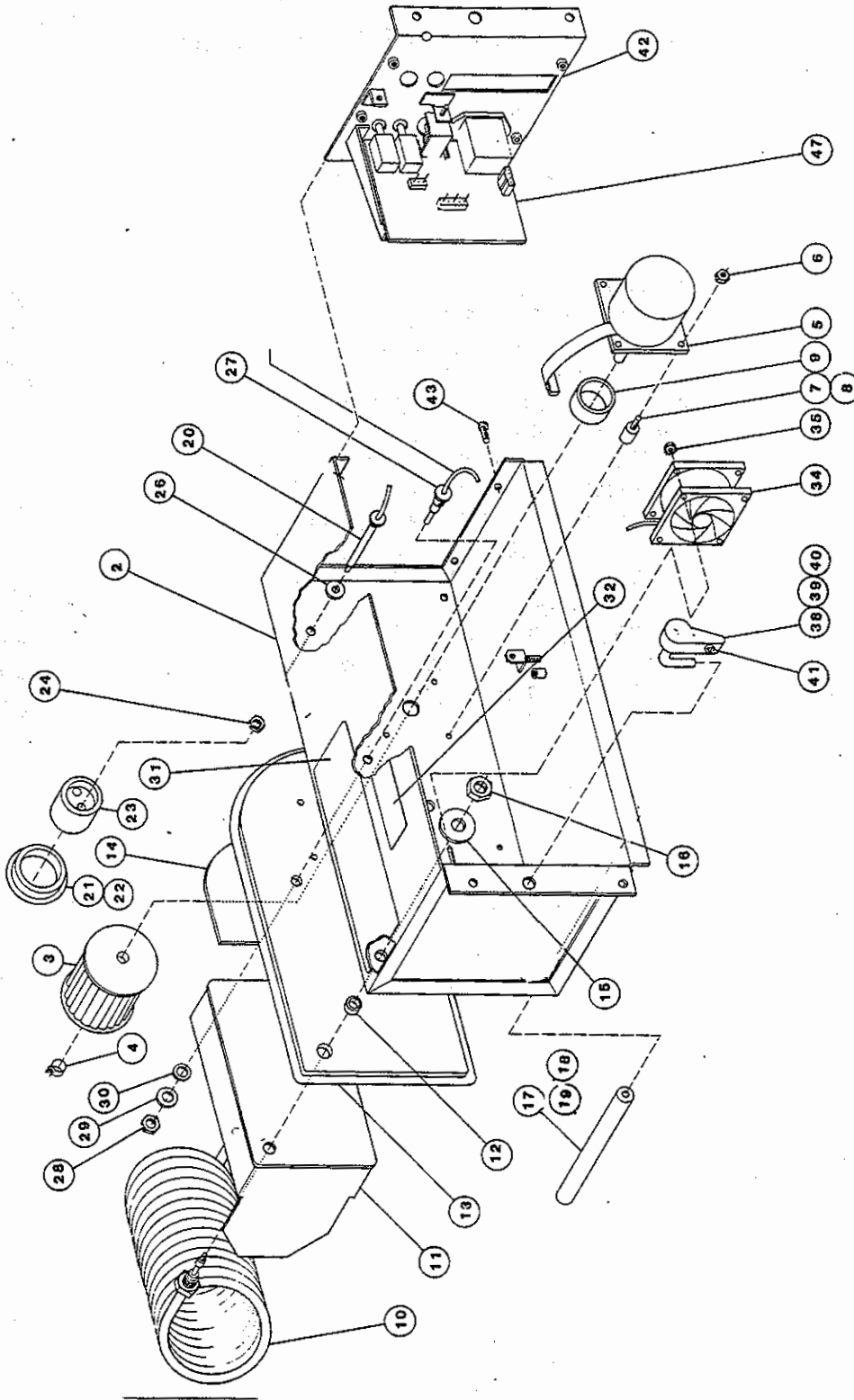

**FIGURE 6.7 PARTS LOCATION DIAGRAM, CONTROLLER ASSEMBLY
(SHEET 1 OF 3)**

Change 1

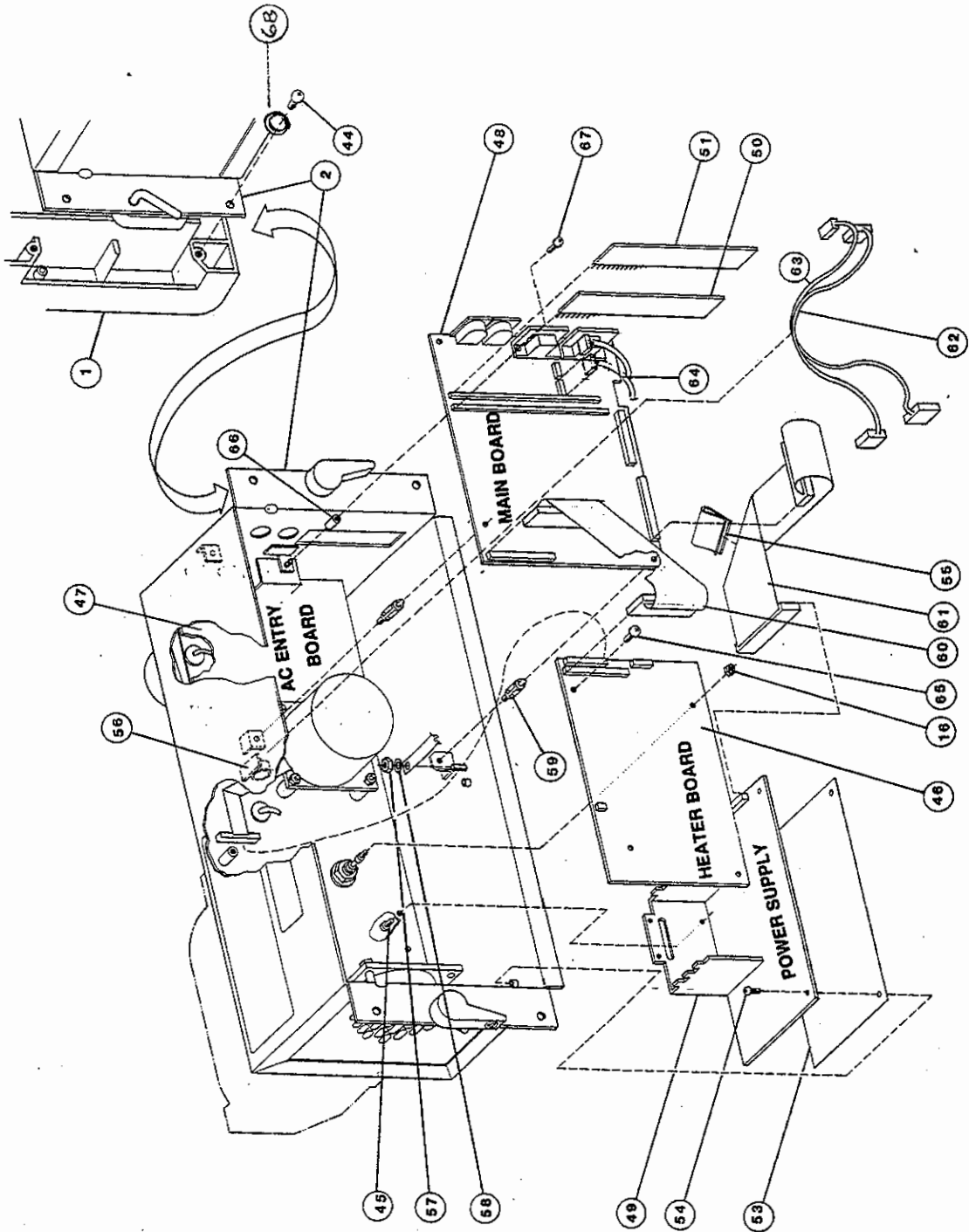

**FIGURE 6.7 PARTS LOCATION DIAGRAM, CONTROLLER ASSEMBLY
(SHEET 2 OF 3)**

Change 6

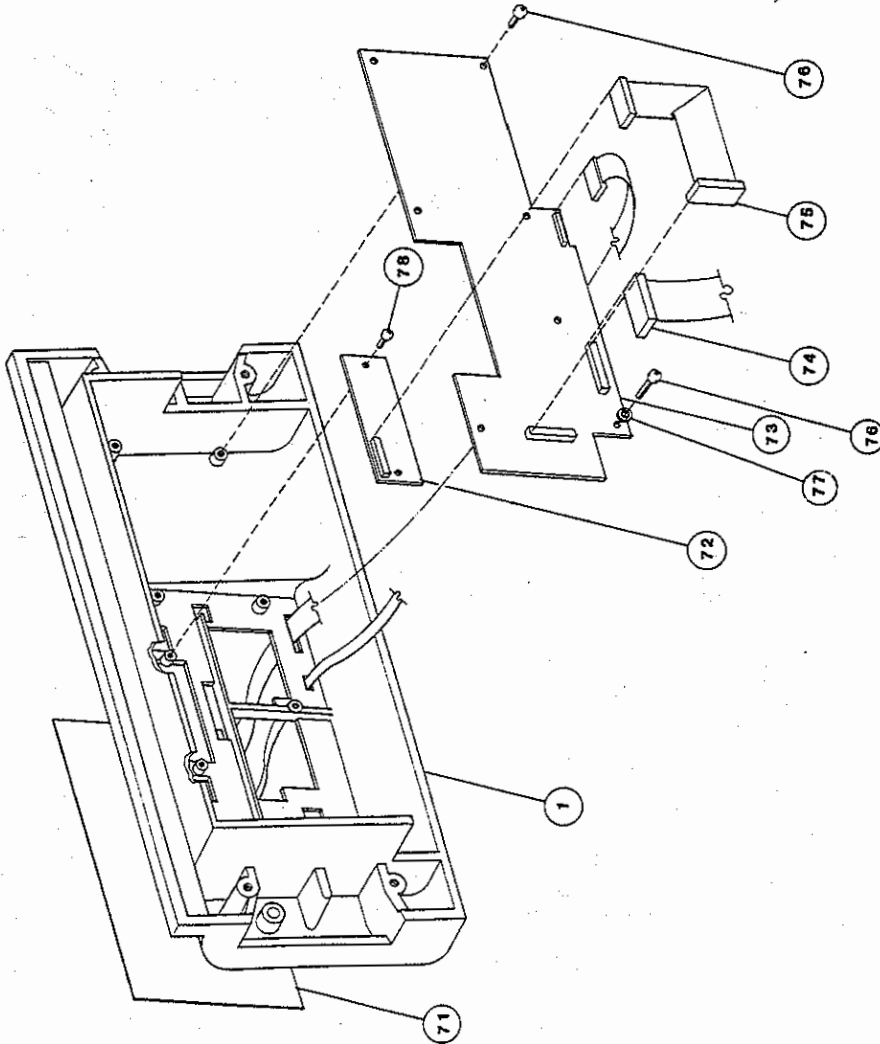

**FIGURE 6.7 PARTS LOCATION DIAGRAM, CONTROLLER ASSEMBLY
(SHEET 3 OF 3)**

TABLE 6.7 CONTROLLER ASSEMBLY, PARTS LIST

CONTROLLER, C500 120V ENG, SPN AND FRN	68 230 70, 71 AND 72
CONTROLLER, C500 220V ENG, SPN, FRN AND ITL	68 230 80, 81, 82 AND 84
CONTROLLER, C500 220V GER	68 230 83
CONTROLLER, C550 120V ENG, SPN AND FRN	68 231 70, 71 AND 72
CONTROLLER, C550 220V ENG, SPN, FRN AND ITL	68 231 80, 81, 82 AND 84
CONTROLLER, C550 220V GER	68 231 83

(Sheet 1 of 3)

ITEM NO.	REFERENCE DESIG.	DESCRIPTION	PART NUMBER
1		CONTROLLER HOUSING	68 230 05
2		CONTROLLER CHASSIS	68 230 00
3		IMPELLER	68 205 41
4		HOSE CLAMP	20 015 65
5		MOTOR ASSEMBLY	68 230 20
6		HEX NUT, 8-32 HEX, SS	99 106 01
7		VIBRATION ISOLATOR	68 230 24
8		LOCTITE #222	AR
9		MOTOR SHAFT SEAL	68 230 27
10		HEATER, 120 V	68 230 35
		HEATER, 240 V	68 230 36
11		HEATER BAFFLE PLATE	68 208 20
12		HEATER PLATE SPACER	26 516 05
13		GASKET	26 503 00
14		STIFFENER PLATE	68 230 46
15		LOCK WASHER 7/16" ID	99 127 41
16		HEATER ASSEMBLY NUT, 6-32 HEX	99 105 70
17		POST BUMPER	68 215 12
18		COMPOUND, LOCTITE RC680	AR
19		LOCQUIC PRIMER, GR "T" #47 - 56	AR
20		DUAL THERMISTOR ASSEMBLY	68 214 76
21		GASKET	26 501 00
22		CEMENT, 3M, EC800	AR
23		THERMOSTAT PLUG	12 512 01
24		NUT, HEX , 15/32- 32 UNF 2B	68 215 11
25		NOT USED	
26		SHOULDER WASHER, INSULATING	99 127 69
27		AIR FLOW THERMISTOR ASSEMBLY	68 214 81
28		NUT, 3/8" X 24, HEX, BR, NI, THIN	99 111 80
29		FLAT WASHER, 3/8" ID X 0.62 OD	99 126 70
30		FIBER WASHER	17 803 40
31		HEATER CAUTION LABEL	68 208 30
32		NOT USED	
33		CHASSIS STERILIZING CAUTION LABEL, MOUNTED DIRECTLY UNDER ITEM 23, ENG	68 212 15
		SPN	68 212 17
		FRN	68 212 18
		GER	69 212 19
		ITL	68 212 20

Change 7

TABLE 6.7 CONTROLLER ASSEMBLY, PARTS LIST

(Sheet 2 of 3)

ITEM NO.	REFERENCE DESIG.	DESCRIPTION	PART NUMBER
34		COOLING FAN ASSEMBLY	68 230 60
35		HEX NUT, 6 - 32 KEPS	99 165 34
36		NOT USED	
38		O-RING, 0.370 ID C 0.40 W	99 160 55
39		LATCH ASSEMBLY, RIGHT	68 230 11
40		LATCH ASSEMBLY, LEFT	68 230 10
41		MANUAL REFERENCE LABEL	68 160 05
42		RIGHT SIDE CHASSIS	68 230 01
43		SCREW, 8 - 32 X 3/8" PHILLIPS HEAD	99 031 38
44		SCREW, 6 - 32 X 3/8 PHILLIPS HEAD	99 041 33
45		SCREW, 6 - 32 X 1/4 PN PH SS SEMS, EX	99 022 83
46		HEATER BOARD ASSY (REF TO TABLE 6.10) 100/120V	68 366 70
		220/240V	68 366 71
		100V	68 366 72
47		AC ENTRY BOARD, (REFER TO TABLE 6.9) 100 VAC	68 365 72
		120 VAC	68 365 70
		220/240 VAC	68 365 71
		230 VAC (GER)	68 365 73
48		MAIN BOARD (REFER TO TABLE 6.11)	
		120V ENGLISH	68 908 40
		120V US AND CANADA ONLY	68 908 41
		INTERNATIONAL	68 908 42
		GERMAN	68 908 43
		RUSSIAN	68 908 44
49		POWER SUPPLY	68 230 30
50		MONITOR HYBRID BOARD	68 367 70
51		CONTROL HYBRID BOARD	68 368 70
52		NOT USED	
53		POWER SUPPLY INSULATOR	68 230 28
54		SCREW, 6 - 32 X 1/4" SQ, CONE, WHR, SEMS	99 022 84
55		RIBBON CABLE CLAMP	17 062 11
56		CORD CLIP	17 725 44
57		NUT, 6 - 32, HEX FL KEPS	99 105 70
58		FLAT WASHER, #6 SS	99 122 03
59		PCB SPACER, 0.50" LG PLASTIC	17 062 72
60		CABLE ASSEMBLY MAIN BOARD TO HEATER BOARD	68 231 05
61		CABLE ASSEMBLY, POWER SUPPLY TO MAIN BOARD	68 231 07
62		CABLE ASSEMBLY, POWER SUPPLY TO AC ENTRY BD	68 231 08
63		CABLE ASSEMBLY, AC ENTRY BOARD TO HEATER BD	68 231 00
64		CABLE ASSEMBLY, AC ENTRY BOARD TO MAIN BOARD	68 231 03
65		SCREW, 6 - 32 1/4" SQ CON SEMS	99 022 84
66		THREADED STANDOFF	99 116 44
67		SCREW, 4 - 40 X 3/8" SEMS	99 011 13
68		LOCK WASHER, INT TOOTH #10 SS	99 123 92
69		NOT USED	
70		NOT USED	

Change 6

TABLE 6.7 CONTROLLER ASSEMBLY, PARTS LIST

(Sheet 3 of 3)

ITEM NO.	REFERENCE DESIG.	DESCRIPTION	PART NUMBER
71		FRONT PANEL OVERLAY C550 ENG	68 231 50
		C550 INTERNATIONAL	68 231 52
		FRONT PANEL OVERLAY C500 ENG	68 230 50
		C500 GER	68 230 53
		C500 INTERNATIONAL	68 230 52
72		VACUUM FLUORESCENT DISPLAY MODULE	17 777 39
73		DISPLAY BOARD ASSEMBLY C500 (REFER TO TABLE 6.12)	68 371 71
		DISPLAY BOARD ASSEMBLY C550 (REFER TO TABLE 6.12)	68 371 70
74		CABLE ASSEMBLY, MAIN BOARD TO DISPLAY BD	68 231 04
75		CABLE ASSEMBLY, VFD MODULE TO DISPLAY BD	68 231 06
76		SCREW, 6-32 1/4 SEMS	99 022 84
77		NOT USED	
86		FILTER COVER LABEL ENG	26 330 60
		FILTER COVER LABEL SPN	26 330 61
		FILTER COVER LABEL FRN	26 330 62
		FILTER COVER LABEL GER	26 330 63
		FILTER COVER LABEL ITL	26 330 64
87		FILTER	26 313 70
88		FILTER COVER KNOB	68 130 30
89		FILTER COVER KNOB SHAFT	68 130 35
90		KNOB HANDLE	68 130 40

Change 6

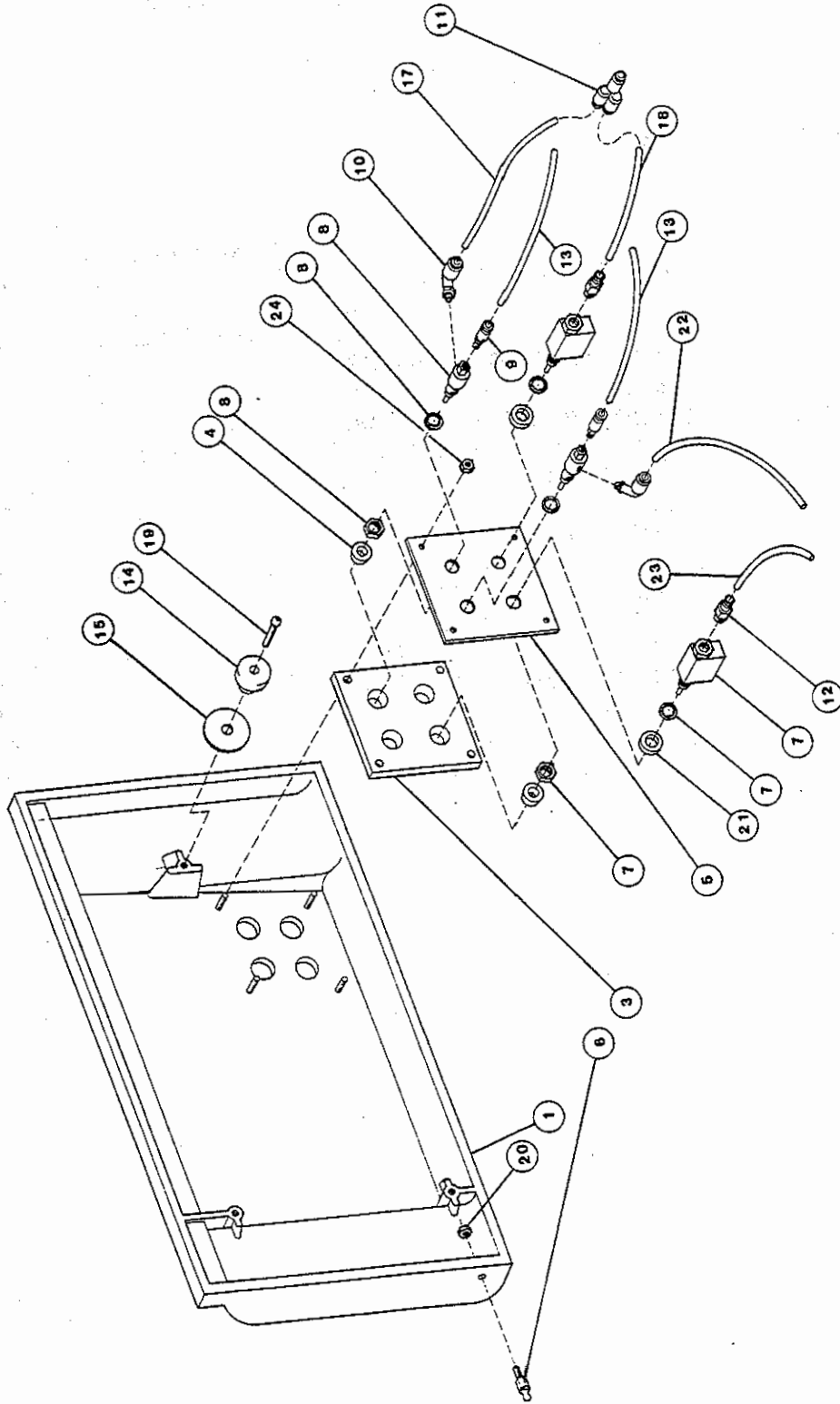

FIGURE 6.8 PARTS LOCATION DIAGRAM, PNEUMATIC PANEL ASSEMBLY

TABLE 6.8 PNEUMATIC PANEL ASSEMBLY, PARTS LIST

(Sheet 1 of 1)

ITEM NO.	REFERENCE DESIG.	DESCRIPTION	PART NUMBER
1		PNEUMATIC TILT BEZEL	68 504 00
2		PNEUMATIC TILT BEZEL LABEL, ENG	68 504 10
		PNEUMATIC TILT BEZEL LABEL, SPN	68 504 11
		PNEUMATIC TILT BEZEL LABEL, FRN	68 504 12
		PNEUMATIC TILT BEZEL LABEL, GER	68 504 13
		PNEUMATIC TILT BEZEL LABEL, ITL	68 504 14
3		KEYPAD	68 504 02
4		KEYPAD SEALING RING	68 504 03
5		KEYPAD MOUNTING PLATE	68 504 04
6		BALL STUD, 6 - 32 EXT THREAD	68 504 05
7		CONTROL VALVE, MINI TWO WAY, MODIFIED	68 504 68
8		CONTROL VALVE, MINI TWO WAY	68 504 21
9		TUBING FITTING, MALE, STRAIGHT, CONN	68 504 25
10		TUBING FITTING, ELBOW, MALE	68 504 27
11		TUBING FITTING, UNION "Y"	68 504 23
12		TUBING FITTING, MALE STRAIGHT, CONN	68 504 26
13		CLEAR TUBING, 3" LONG	68 505 12
14		RETAINING KNOB	68 156 67
15		FLAT WASHER, DELRIN	99 122 07
16		NOT USED	
17		BLUE TUBING, 3" LONG	68 505 22
18		BLUE TUBING 2-1/2" LONG	68 505 23
19		SCREW, 6 - 32 X 9/16" TR PH SS NYLOCK	99 024 19
20		NUT, #6 HEX KEPS	99 105 34
21		NYLON WASHER, 0,505 OD X 0.75 ID X 0.125 THK	99 127 74
22		RED TUBING, 3 1/2" LONG	68 505 32
23		RED TUBING, 2 1/2" LONG	68 505 33
24		NUT, NO. 4 KEPS	99 103 33

Change 6

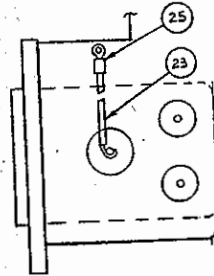
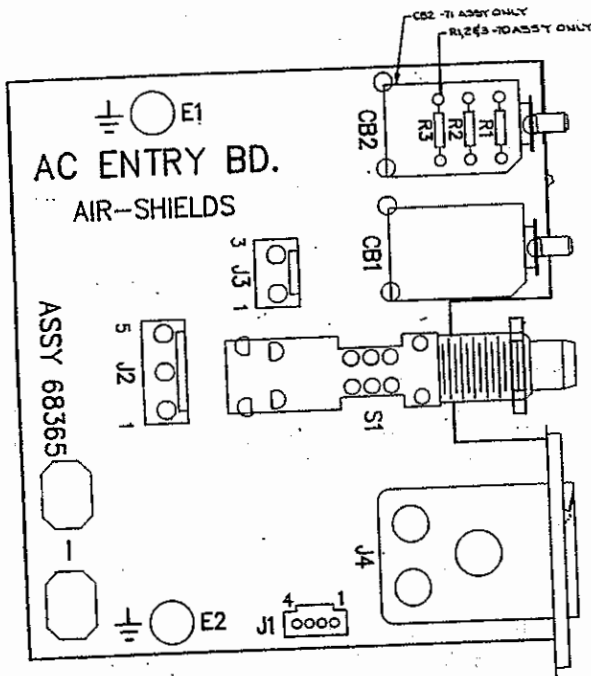

68 365 70, 71 and 72

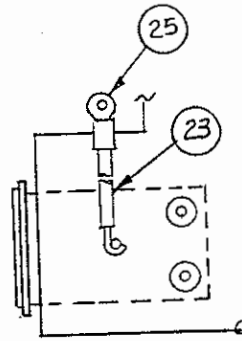
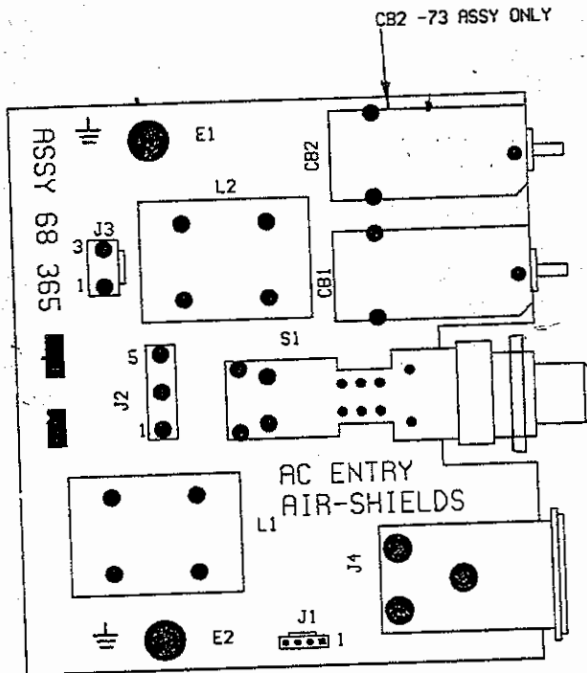

68 365 73

FIGURE 6.9 PARTS LOCATION DIAGRAM, AC ENTRY BOARD

Change 4

**TABLE 6.9 AC ENTRY BOARD, C500/550 QT®, C500/550 QT® MODEL XL,
PARTS LIST**

(Sheet 1 of 1)

ITEM NO.	REFERENCE DESIG.	DESCRIPTION	PART NUMBER
		AC ENTRY BOARD 120 Vac	68 365 70
		AC ENTRY BOARD 220/240 Vac	68 365 71
		AC ENTRY BOARD 100 Vac	68 365 72
		AC ENTRY BOARD 230 Vac GERMAN	68 365 73
1		NOT USED	
2		NOT USED	
3		NOT USED	
4		NOT USED	
5		NOT USED	
6		NOT USED	
7		NOT USED	
8		NOT USED	
9		NOT USED	
10	S1	PUSHBUTTON SWITCH	17 682 46
		LAMP FOR SWITCH 17 682 46	17 807 78
11		NOT USED	
12		NOT USED	
13	J1	CONN., PC HEADER, 4 POS 0.100 CTR	17 BR 852
14	J2	CONN., PC HEADER, 5 POS 0.156 CTR	17 BR 903
15	J3	CONN., PC HEADER, 3 POS 0.156 CTR	17 BR 901
16	J4	CONN., RCPT, MALE RFI FILTER	17 734 30
17		NOT USED	
18		NOT USED	
19	CB1	CIRCUIT BREAKER, SP, 6.0 AMPS – 120 Vac UNITS	17 BH 189
	CB1,CB2	CIRCUIT BREAKER, SP, 6.0 AMPS – 100 Vac UNITS	17 BH 189
	CB1,CB2	CIRCUIT BREAKER, SP, 3.0 AMPS – 220/240 Vac UNITS ...	17 BH 184
20		NOT USED	
21	R1,R2,R3	RESISTOR, JUMPER	17 217 62
22		NOT USED	
23		GREEN/YELLOW WIRE, 18 AWG, 600 V	17 717 65
24		NOT USED	
25		TERMINAL RING, INS #6 22 – 16	17 722 41
26		NOT USED	
27	L1,L2	LINE FILTER, 250V 4 AMPS, 29 mH	17 585 56
		68 365 73 ONLY	

Change 4

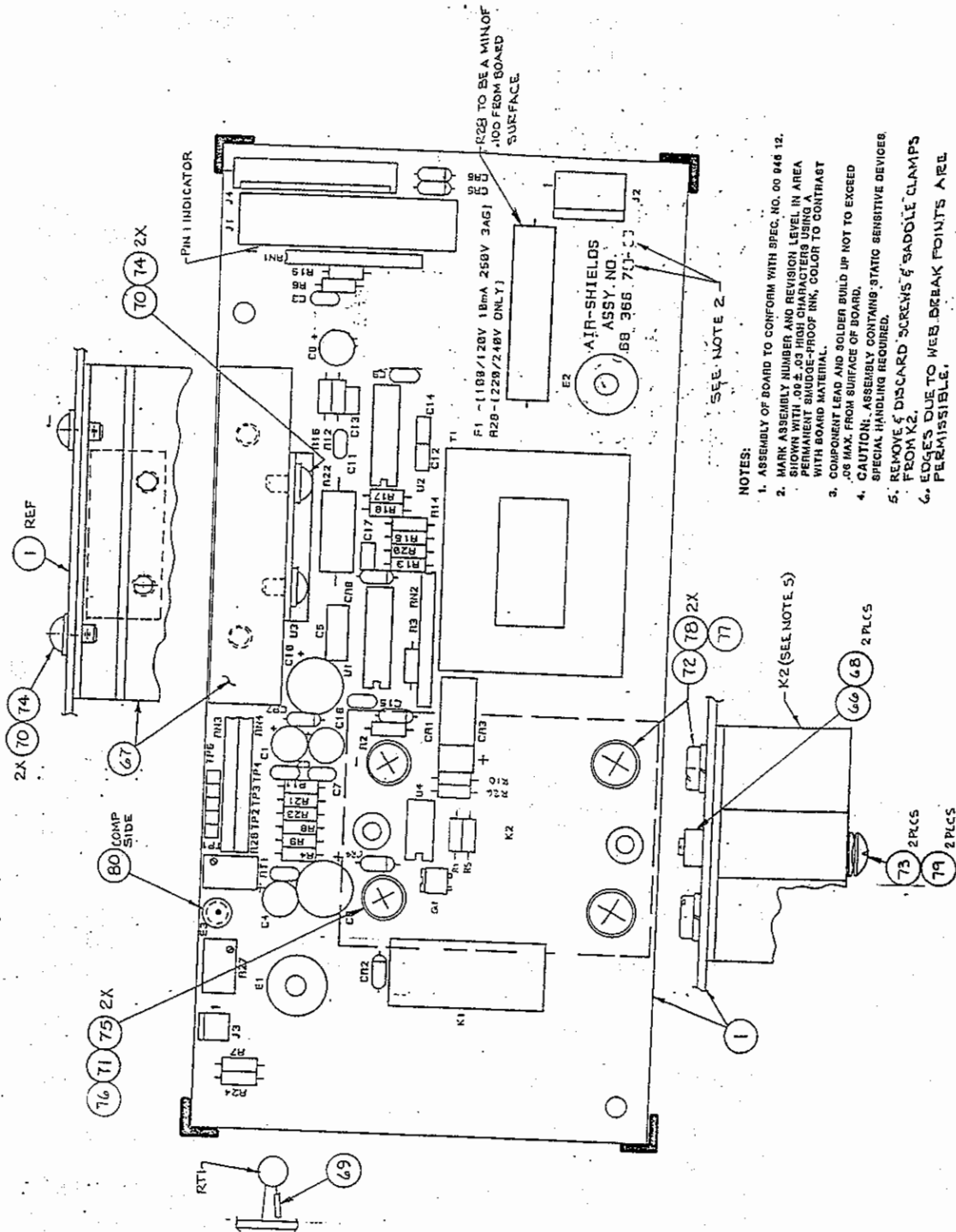

- NOTES:
1. ASSEMBLY OF BOARD TO CONFORM WITH SPEC. NO. 00 946 12.
 2. MARK ASSEMBLY NUMBER AND REVISION LEVEL IN AREA SHOWN WITH .02 ± .03 HIGH CHARACTER HEIGHT. USE PERMANENT SNIFFAGE-PROOF INK, COLOR TO CONTRAST WITH BOARD MATERIAL.
 3. COMPONENT LEAD AND SOLDER BUILD UP NOT TO EXCEED .05 MAX. FROM SURFACE OF BOARD.
 4. CAUTION: ASSEMBLY CONTAINS STATIC SENSITIVE DEVICES. SPECIAL HANDLING REQUIRED.
 5. REMOVE & DISCARD SCREWS & SADDLE CLAMPS FROM K2.
 6. EDGES DUE TO WEB BREAK POINTS ARE PERMISSIBLE.

FIGURE 6.10 PARTS LOCATION DIAGRAM, HEATER BOARD

Change 6

TABLE 6.10 HEATER BOARD, PARTS LIST

(Sheet 1 of 2)

ITEM NO.	REFERENCE DESIG.	DESCRIPTION	PART NUMBER
		HEATER BOARD ASSEMBLY (100V/120V)	68 366 70
		HEATER BOARD ASSEMBLY (220V/240V)	68 366 71
		HEATER BOARD ASSEMBLY (100V)	68 366 72
1		NOT USED	
2		NOT USED	
3		NOT USED	
4		NOT USED	
5		NOT USED	
6		NOT USED	
7		NOT USED	
8		NOT USED	
9		NOT USED	
10	C1, 4,8, 16	CAP., TANT., 10 UF, $\pm 10\%$ 25 VDC	17 AW 236
11	C6, C10	CAP., PAPER, 47 UF +50%, - 10%	17 AW 411
12	C5	CAP., 0.22 UF, $\pm 10\%$ 63 VDC	17 AY 138
13	C2,3,7,9,11,15,17	CAP., 0.1 UF, $\pm 10\%$ 50 VDC	17 BF 217
14	C12,13,14	CAP., 100 PF, $\pm 10\%$ 50 VDC	17 BF 365
15		NOT USED	
16		NOT USED	
17	F1	FUSE, PIGTL, 0.01A, 250V	17 BM 090
18		NOT USED	
19	J1	CONN, PC HDR, PLZD, 26 POSN	17 BP 654
20	J2	CONN, PC HDR, MALE, PLZD, 3 POSN	17 BR 901
21	J3	CONN, PC HDR, MALE, PLZD, LKG, 2 POSN	17 BS 132
22	J4	CONN, PC HDR, MALE, PLZD, LKG, 12 POSN	17 BS 142
23		NOT USED	
24	CR1,2,5,6,8	DIODE, 1N914A	17 AR 501
25	CR4, 7	DIODE, 1N4733A	17 502 20
26	CR3	DIODE BRIDGE, 1.5A, 100V	17 AS 201
27		NOT USED	
28	U3	IC, MOTOR CONTROLLER	17 633 62
29	U1	IC, MC14106B	17 633 60
30	U4	IC, DUAL OP-AMP, LM358A	17 631 85
31	U2	IC, QUAD COMPARATOR, 3302	17 629 58
32		NOT USED	
33		NOT USED	
34	K2	RELAY, SPST-N.O. 280V, 45A (SOLID STATE RELAY)	17 652 99
35	K1	RELAY, DPST-N.O. 250V, 10A	17 652 98
36		NOT USED	
37	R5,R6	RESISTOR, 130 OHM, 1%, 1/8W	17 AF 107
38	R19	RESISTOR, 432 OHM, 1%, 1/8W	17 AF 157
39	R4,7,23	RESISTOR, 0 OHM	17 217 62
40	R21	RESISTOR, 255 OHM, 1%, 1/8W	17 AF 135
41	R17,18	RESISTOR, 2.49K, 1%, 1/8W	17 AF 230

Change 5

TABLE 6.10 HEATER BOARD, PARTS LIST

(Sheet 2 of 2)

ITEM NO.	REFERENCE DESIG.	DESCRIPTION	PART NUMBER
42	R11	RESISTOR, 2.94K, 1 %, 1/8W	17 AF 237
43		NOT USED	
44	R24	RESISTOR, 35.7K, 1 %, 1/8W	17 AF 341
45	R9	RESISTOR, 52.6K, 1 %, 1/8W	17 AF 360
46	R8	RESISTOR, 100K, 1 %, 1/8W	17 AF 384
47	R12,16	RESISTOR, 200K, 1 %, 1/8W	17 AF 413
48	R10	RESISTOR, 3.09K, 1 %, 1/8W	17 AF 239
49	R20	RESISTOR, 5.10K, 1 %, 1/8W	17 AF 779
50	R25	RESISTOR, 154K, 1 %, 1/8W	17 AF 402
51	R1,13,14,15	RESISTOR, 1.00M, 1 %, 1/8W	17 AH 889
52	R22	RESISTOR, 0.15 OHM, 5%, 2W, WW	17 AN 444
53	R2,3	RESISTOR, 6.98K, 1 %, 1/8W	17 AF 273
54	R26,27	POTENTIOMETER, 5K, 10%, 0.5W	17 AN 126
55		NOT USED	
56	RN1,2	RESISTOR, SIP, 10K	17 AU 227
57	RN3,4	RESISTOR, SIP, 4.7K	17 AU 215
58		NOT USED	
59	TP1-5	CONN, PC, HEADER, SGL ROW, 5 PINS	17 BP 375
60		NOT USED	
61	RT1	THERMISTOR, NTC, 10K, 1%	17 575 25
62	T1	POWER TRANSFORMER	17 605 48
63		NOT USED	
64	Q1	TRANSISTOR, IRFD110	17 627 97
65		NOT USED	
66		LOCTITE, SCREWLOCK222	AR
67	UX3	HEAT SINK	68 366 25
68		NUT, SELFCLINCHING, 6-32	99 105 65
69		TEFLON SLEEVING, 0.531 ID	AR
70		SCREW, 4 - 40 X 1/4" TR PH SS SEMS	99 010 65
71		SCREW, 6 - 32 X 5/16" TR PH SS SEMS	99 023 05
72		SCREW, 8 - 32 X 3/8" TR PH SS SEMS	99 031 50
73		SCREW, 6-32 X 1.25 TR PH SS	99 025 69
74		FLAT WASHER, NO. 4 SS	99 121 21
75		FLAT WASHER, NO. 6 SS	99 122 03
76		NOT USED	
77		NOT USED	
78		FLAT WASHER, NO. 8 SS	99 122 62
79		WASHER, SQ CONE #6, 0.025 THK	99 122 21
80		STANDOFF, THREADED, 4 - 40 C 0.625 LG, SS	99 116 45

Change 6

(This page is intentionally left blank.)

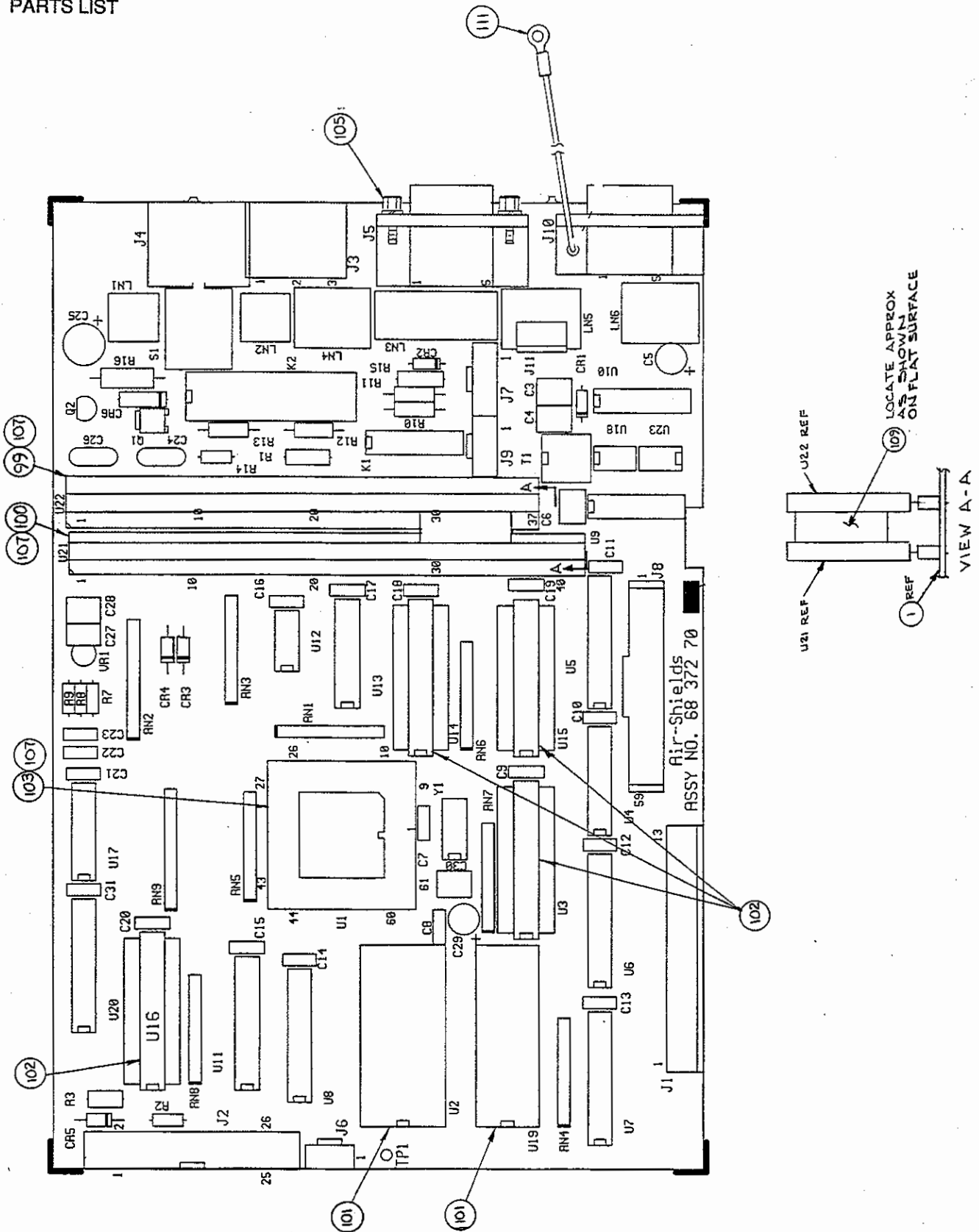

FIGURE 6.11 PARTS LOCATION DIAGRAM, MAIN BOARD

Change 1

TABLE 6.11 MAIN BOARD, PARTS LIST

(Sheet 1 of 1)

ITEM NO.	REFERENCE DESIG.	DESCRIPTION	PART NUMBER
----------	------------------	-------------	-------------

THE MAIN BOARD IS A MULTI-LAYER BOARD. THE ITEMS LISTED BELOW ARE THE ONLY COMPONENTS THAT CAN BE REPLACED IN THE FIELD. ATTEMPTING TO REPLACE ANY OTHER COMPONENT MAY RESULT IN DAMAGE TO THE BOARD.

		MAIN BOARD ASSEMBLY 120V ENG	68 908 40
		MAIN BOARD ASSEMBLY US AND CANADA	68 908 41
		MAIN BOARD ASSEMBLY INTERNATIONAL	68 908 42
		MAIN BOARD ASSEMBLY GERMAN	68 908 43
		MAIN BOARD ASSEMBLY RUSSIAN	68 908 44
1	U1	PROCESSOR, 68HC11F1	17 633 59
2	U2	FIRMWARE, C500/C550 CONTROLLER ENG & INT	68 372 50
		FIRMWARE, C500/C550 CONTROLLER US & CAN	68 372 51
		FIRMWARE, C500/C550 CONTROLLER GER	68 372 52
		FIRMWARE, C500/C550 CONTROLLER RUS	68 372 53
3	U3	FIRMWARE, MAIN BOARD DECODER	68 372 45
4	U14	FIRMWARE, ALARM LOGIC 1	68 372 30
5	U15	FIRMWARE, ALARM LOGIC 2	68 372 35
6	U16	FIRMWARE, ALARM LOGIC 3	68 372 40
7	U21	MONITOR HYBRID	68 367 70
8	U22	CONTROL HYBRID	68 368 70
105		SCREW LOCK, 4 - 40	505C00022-02
111		JUMPER WIRE, GND CONN	68 372 64

Change 6

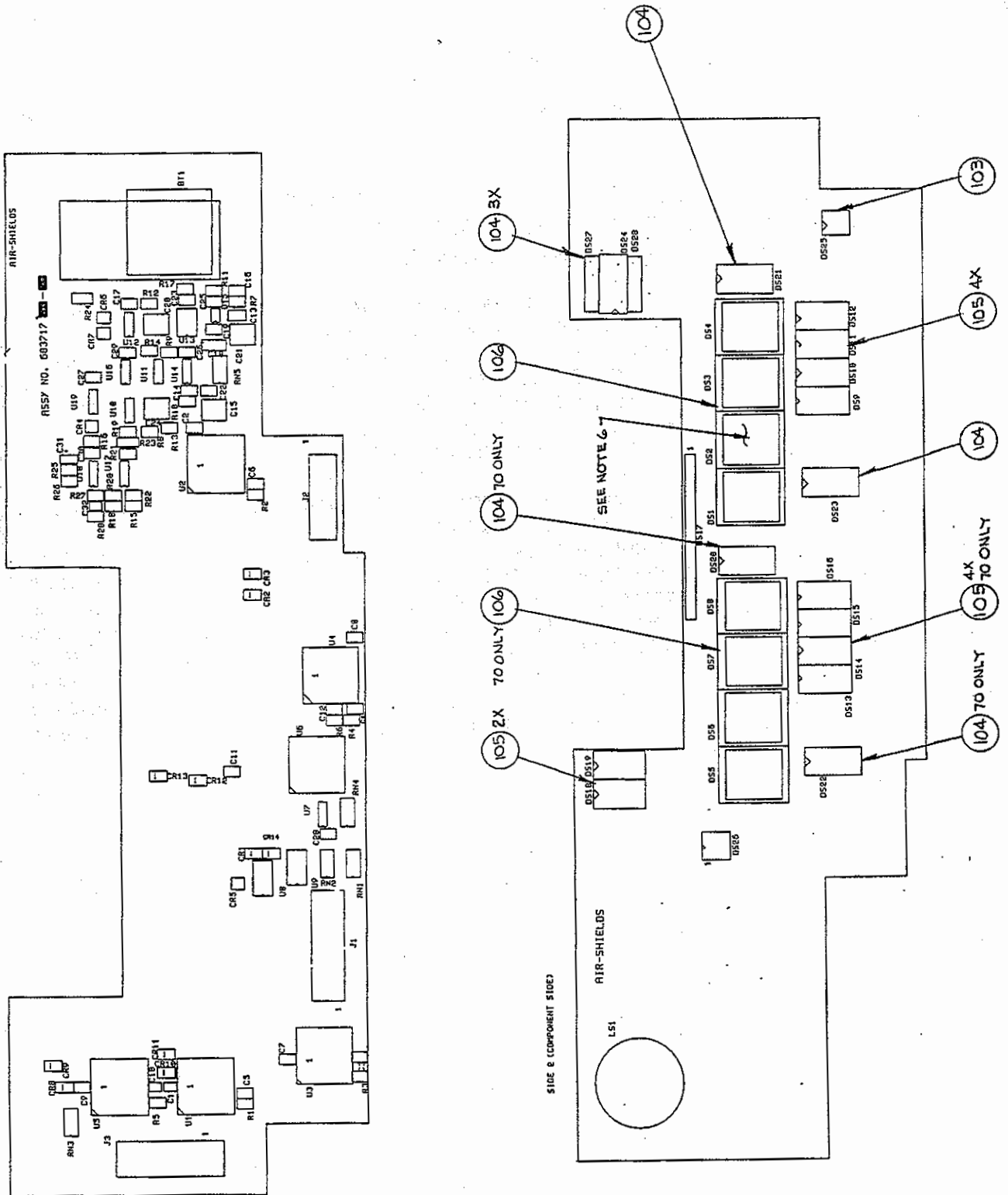

FIGURE 6.12 PARTS LOCATION DIAGRAM, DISPLAY BOARD

TABLE 6.12 DISPLAY BOARD, PARTS LIST

(Sheet 1 of 1)

ITEM NO.	REFERENCE DESIG.	DESCRIPTION	PART NUMBER
----------	------------------	-------------	-------------

THE DISPLAY BOARD IS A MULTI-LAYER BOARD. THE ITEMS LISTED BELOW ARE THE ONLY COMPONENTS THAT CAN BE REPLACED IN THE FIELD. ATTEMPTING TO REPLACE ANY OTHER COMPONENT MAY RESULT IN DAMAGE TO THE BOARD.

		DISPLAY BOARD ASSEMBLY C500	68 371 71
		DISPLAY BOARD ASSEMBLY C550	68 371 70
		DISPLAY BOARD ASSEMBLY C550 JAP	68 371 72
1	DS9-16,18,19	DISPLAY, HP HDSP 3601	
2	DS29,21	DISPLAY, HP HLMP 2770	
3	DS22,23	DISPLAY, HP HLMP 2885	
4	DS24	DISPLAY, HP HLMP 2685	
5	DS25	DISPLAY, HP HLMP 2855	
6	DS26	DISPLAY, HP HLMP 2755	
7	DS27,28	DISPLAY, HP HLMP 2350	
8	BT1*	BATTERY, 4.8 VOLT, 0.1AH NI CAD	17 807 79

*CAUTION: The display printed circuit board is a 6 layer PCB. Extreme caution should be used when handling and performing this procedure.

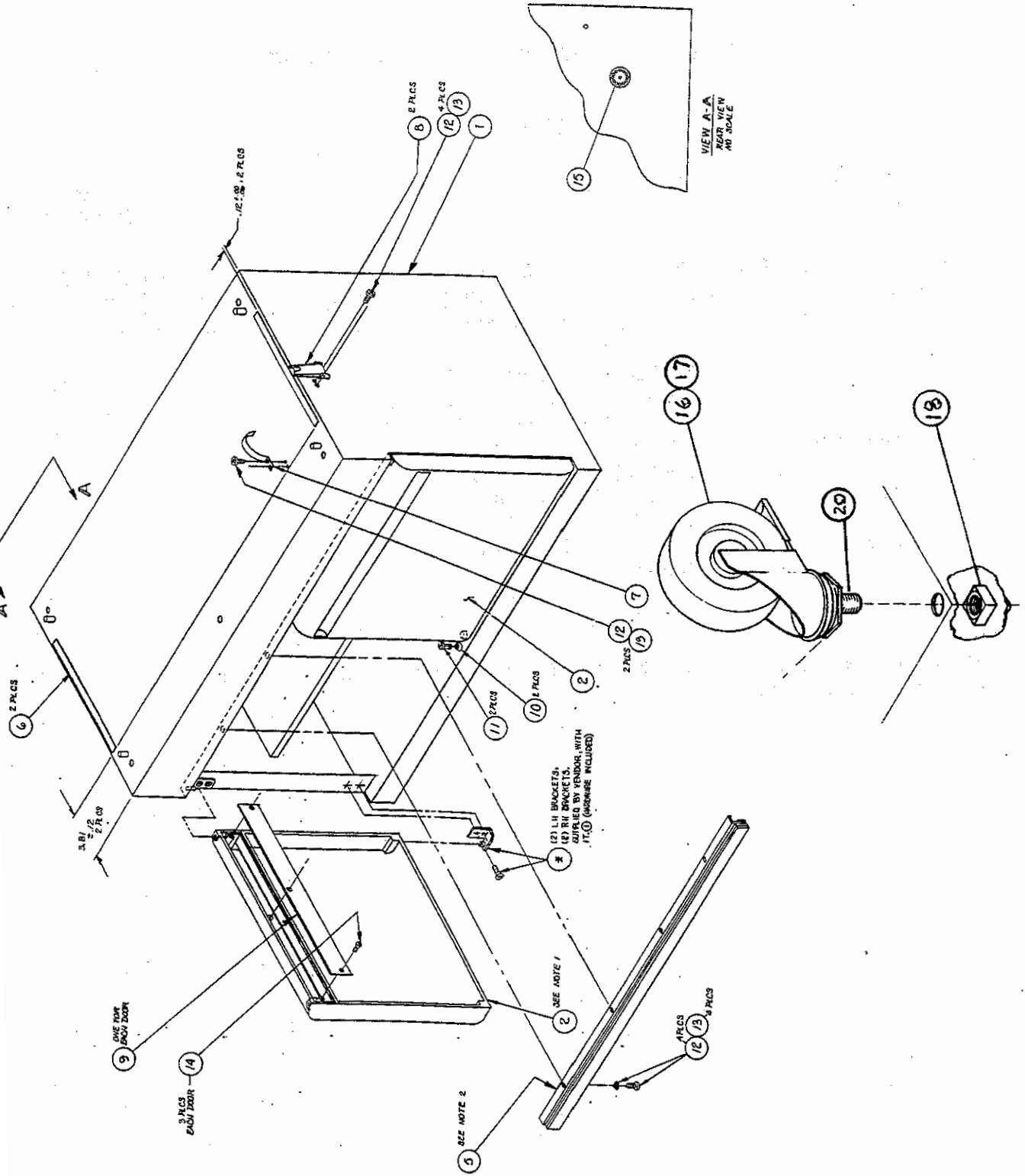

FIGURE 6.13 PARTS LOCATION DIAGRAM, CABINET STAND ASSEMBLY

Change 1

TABLE 6.13 CABINET STAND ASSEMBLY, PARTS LIST

(Sheet 1 of 1)

ITEM NO.	REFERENCE DESIG.	DESCRIPTION	PART NUMBER
		C500/C550 CABINET STAND ASSEMBLY	68 416 30
1		CABINET STAND WELDMENT	68 416 00
2		CABINET STAND DOOR	68 416 05
3		NOT USED	
4		NOT USED	
5		MAGNETIC CATCH ASSEMBLY	68 416 20
6		NEOPRENE SPONGE STRIP, 11" LONG	26 800 33
7		GROUNDING SPRING	68 400 27
8		CABINET LATCH	24 717 00
9		DOOR STRIKER PLATE	68 416 28
10		RECESSED RUBBER BUMPER	26 605 00
11		SCREW, 6 - 32 X 0.38 FI SL SS	99 023 25
12		SCREW, 6 - 32 X 1/4 TR PH SS	99 022 72
13		LOCK WASHER, EXT #6 SS	99 122 20
14		SCREW, SLFPG, 4 - 40 X 3/8 BT FL S NI	99 083 02
15		VENTED HOLE PLUG	68 416 29
16		CASTER, 5.00" DIAMETER WITH BRAKE	68 416 16
17		CASTER, 5.00" DIAMETER WITHOUT BRAKE	68 416 18
18		SQUARE NUT, 1/2 X 13, 13/16 ACROSS FLATS	99 113 03
19		NOT USED	
20		LOCTITE 242	AR

Change 6

(This page is intentionally left blank.)

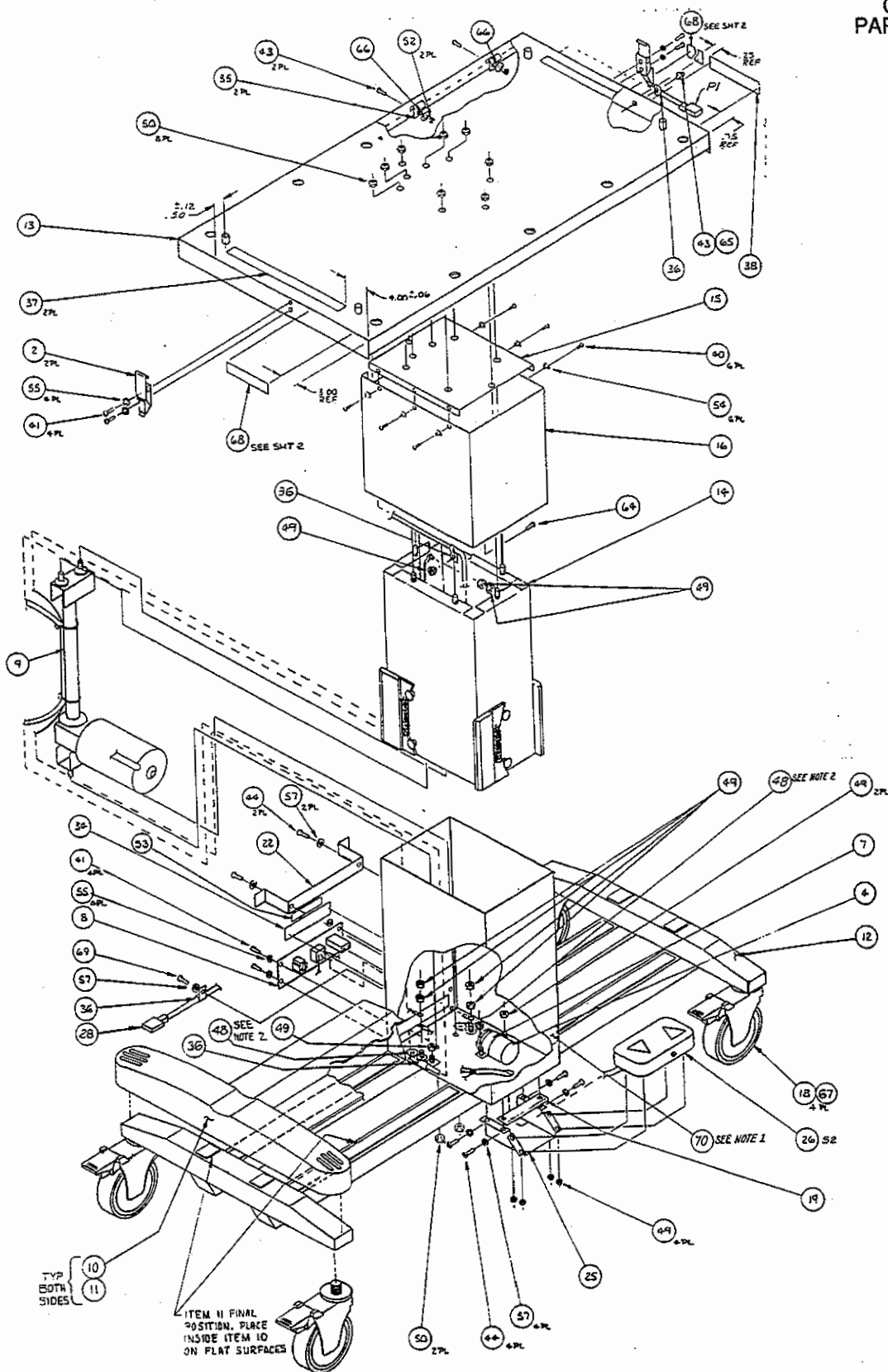
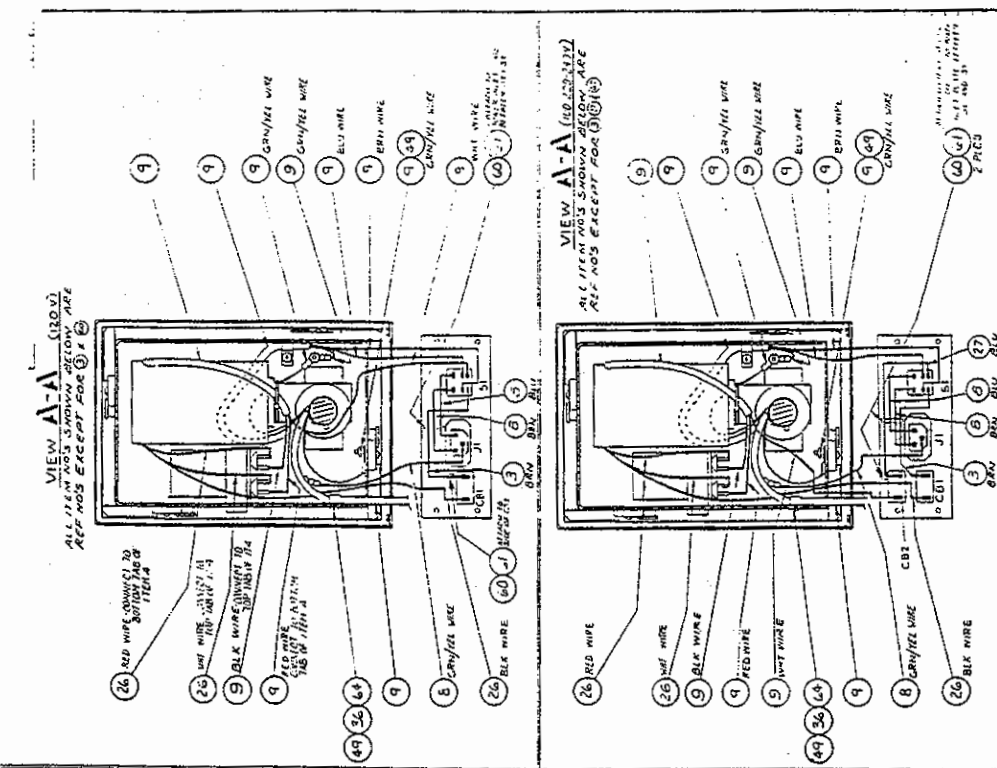
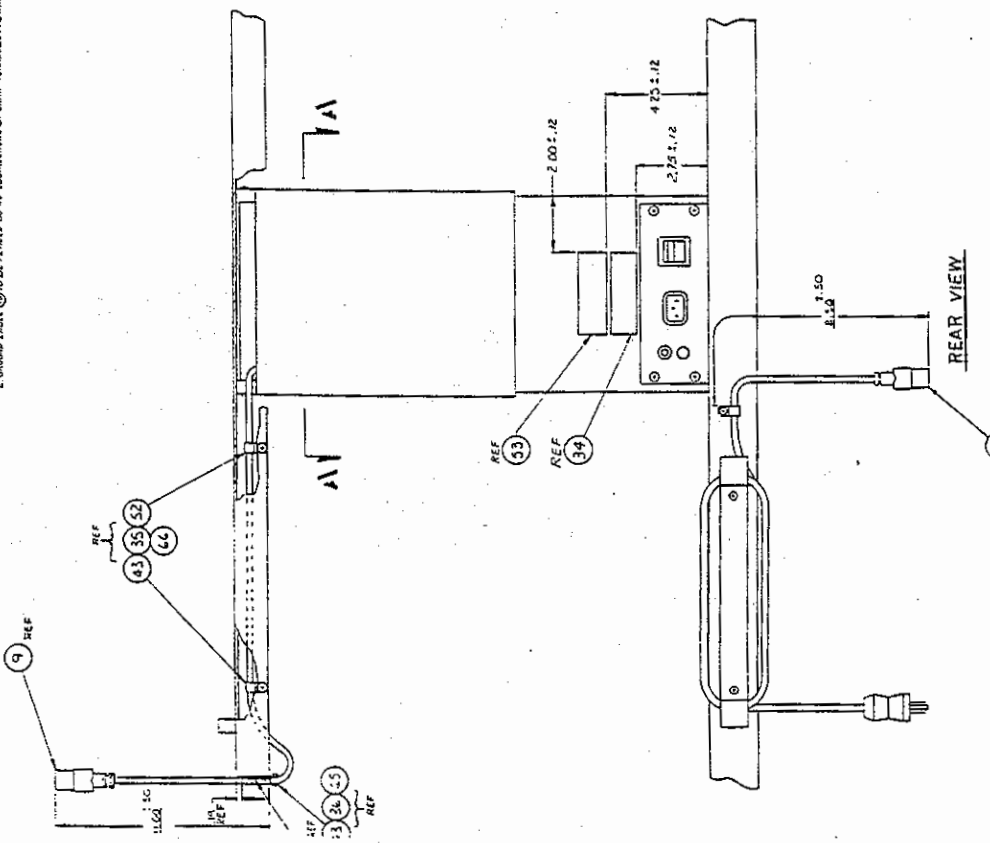

FIGURE 6.14 PARTS LOCATION DIAGRAM, VHA STAND ASSEMBLY (SHEET 1 OF 2)

Change 1



NOTES:
1. BOTTOM EDGE OF LABEL ① TO BE LOCATED 2.00 INCHES FROM BOTTOM OF POST & CENTRALLY
LOCATED LEFT TO RIGHT.
2. GROUND LABEL ② TO BE PLACED SO AS TO BE PARALLEL TO GROUND TERMINALS OF WIRE.



**FIGURE 6.14 PARTS LOCATION DIAGRAM, VHA STAND
ASSEMBLY (SHEET 2 OF 2)**

TABLE 6.14 VHA STAND ASSEMBLY, PARTS LIST

(Sheet 1 of 3)

ITEM NO.	REFERENCE DESIG.	DESCRIPTION	PART NUMBER
		VHA STAND ASSEMBLY, 120V, ENG	68 415 70
		VHA STAND ASSEMBLY, 120V, SPN	68 415 71
		VHA STAND ASSEMBLY, 120V, FRN	68 415 72
		VHA STAND ASSEMBLY, 220/240V, ENG	68 415 80
		VHA STAND ASSEMBLY, 220/240V, SPN	68 415 81
		VHA STAND ASSEMBLY, 220/240V, FRN	68 415 82
		VHA STAND ASSEMBLY, 220V, GER	68 415 83
		VHA STAND ASSEMBLY, 220/240V, ITL	68 415 84
1		NOT USED	
2		DRAW LATCH, MODIFIED	68 404 20
3		JUMPER BRKR SW	68 405 39
4		CAP, 30 MFD, 240V 60HZ, MET PLYPR	17 405 81
		CAP, 10 MFD, 370V 60HZ, MET PLYPR	17 405 82
		CAP, 50 MFD, 240V 60HZ, MET PLYPR	17 405 83
5		NOT USED	
6		NOT USED	
7		CAPACITOR CLAMP 100V/120V UNITS	68 404 24
		CAPACITOR CLAMP, 220/240V UNITS	68 404 25
8		POWER INLET PLATE ASSY, 120V ENG	68 415 50
		POWER INLET PLATE ASSY, 120V SPN	68 415 51
		POWER INLET PLATE ASSY, 120V FRN	68 415 52
		POWER INLET PLATE ASSY, 220/240V ENG	68 415 53
		POWER INLET PLATE ASSY, 220/240V SPN	68 415 54
		POWER INLET PLATE ASSY, 220/240V FRN	68 415 55
		POWER INLET PLATE ASSY, 220V GER	68 414 56
		POWER INLET PLATE ASSY, 220/240V ITL	68 414 58
9		ACTUATOR ASSY 120V 50/60HZ	68 405 32
		ACTUATOR ASSY 220/240V 50/60HZ	68 405 33
		ACTUATOR ASSY 100V 50/60HZ	68 405 32
10		BASE COVER	68 415 01
11		FOAM TAPE, DBL SIDED, 3MY-4952	AR
12		BASE WELDMENT	68 415 00
13		PLATFORM	68 415 05
14		COLUMN, INNER ASSY (REFER TO TABLE 6.12)	68 404 40
15		PLATE, TOP	68 405 13
16		ESCUTCHEON	68 415 20
17		NOT USED	
18		CASTER, 5.00 FULL LOCK	68 416 16
19		COVER PLATE, FOOT SWITCH	68 415 07
20		NOT USED	
21		NOT USED	
22		CLEAT, POWER CORD	68 415 22
23		NOT USED	
24		NOT USED	

Change 4

TABLE 6.14 VHA STAND ASSEMBLY, PARTS LIST

(Sheet 2 of 3)

ITEM NO.	REFERENCE DESIG.	DESCRIPTION	PART NUMBER
25		FOOT SWITCH ASSEMBLY	68 415 46
26		FOOT SWITCH ASSEMBLY INTL	68 405 47
27		JUMPER, BRKR-SW	68 405 30
28		CABLE ASSY, AC POWER 120V	17 AZ 100
		CABLE ASSY, AC POWER 220/240V	17 AZ 200
29		NOT USED	
30		NOT USED	
31		NOT USED	
32		NOT USED	
33		NOT USED	
34		NOT USED	
35		CLAMP, CORD	17 061 25
36		CLAMP, CORD	17 732 42
37		SPONGE STRIP, NEO	26 800 33
38		LABEL, POWER CORD ENG	68 415 30
		LABEL, POWER CORD SPN	68 415 31
		LABEL, POWER CORD FRN	68 415 32
		LABEL, POWER CORD GER	68 415 33
		LABEL, POWER CORD ITL	68 415 34
39		NOT USED	
40		SCREW, 4-40 x 1/4 TR PH SS	99 010 56
41		SCREW, 6-32 x 3/8 TR PH SS	99 023 31
42		NOT USED	
43		SCREW, 8-32 x 3/8 TR PH SS	99 031 38
44		SCREW, 10-32 x 3/8 TR PH SS	99 041 27
45		NOT USED	
46		NOT USED	
47		NOT USED	
48		GROUND LABEL	68 212 00
49		NUT, 6-32 HX "KEPS" S CA	99 105 34
50		NUT, 1/4-20 HX "KEPS" S CA	99 109 41
51		NOT USED	
52		NUT, 8-32 HX "KEP" S CA	99 106 32
53		CAUTION LABEL, ELECTRIC SHOCK, ENG	68 422 90
		CAUTION LABEL, ELECTRIC SHOCK, SPN	68 422 91
		CAUTION LABEL, ELECTRIC SHOCK, FRN	68 422 92
		CAUTION LABEL, ELECTRIC SHOCK, GER	68 422 93
		CAUTION LABEL, ELECTRIC SHOCK, ITL	68 422 94
54		WASHER, #4 LK SP SS	99 121 36
55		WASHER, #6 LK SP SS	99 122 16
56		NOT USED	
57		WASHER, #10 LK SP S CA	99 124 16
58		NOT USED	
59		NOT USED	

Change 1

TABLE 6.14 VHA STAND ASSEMBLY, PARTS LIST

(Sheet 3 of 3)

ITEM NO.	REFERENCE DESIG.	DESCRIPTION	PART NUMBER
60		CABLE TIE MOUNT	17 061 87
61		CATCH, SECONDARY	68 404 21
62		NOT USED	
63		NOT USED	
64		SCREW, 6-32 x 1/2 TR PH SS	99 023 92
65		WASHER, LK EXT #8 SS	99 122 93
66		WASHER, FL #8 SS	99 122 62
67		LOCTITE 222	AR
68		HEAVY EQUIPMENT LABEL, ENG	68 415 40
		HEAVY EQUIPMENT LABEL, SPN	68 415 41
		HEAVY EQUIPMENT LABEL, FRN	68 415 42
		HEAVY EQUIPMENT LABEL, GER	68 415 43
		HEAVY EQUIPMENT LABEL, ITL	68 415 44
69		SCREW, 10 - 32 X 1/2" FL PH SS	99 042 06
70		INTERMITTENT OPERATION LABEL, ENG	68 415 60
		INTERMITTENT OPERATION LABEL, SPN	68 415 61
		INTERMITTENT OPERATION LABEL, FRN	68 415 62
		INTERMITTENT OPERATION LABEL, GER	68 415 63
		INTERMITTENT OPERATION LABEL, ITL	68 415 64

Change 1

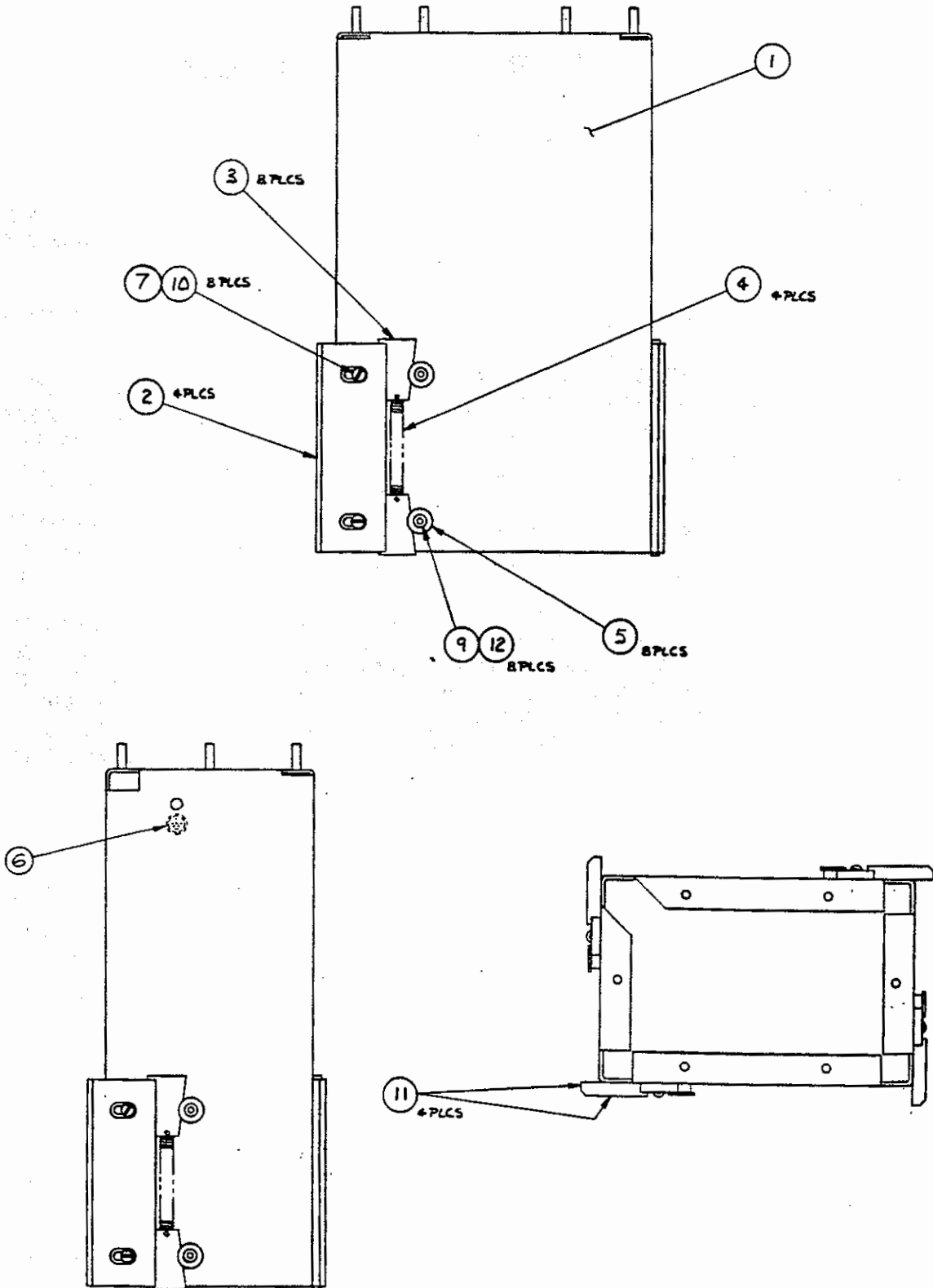
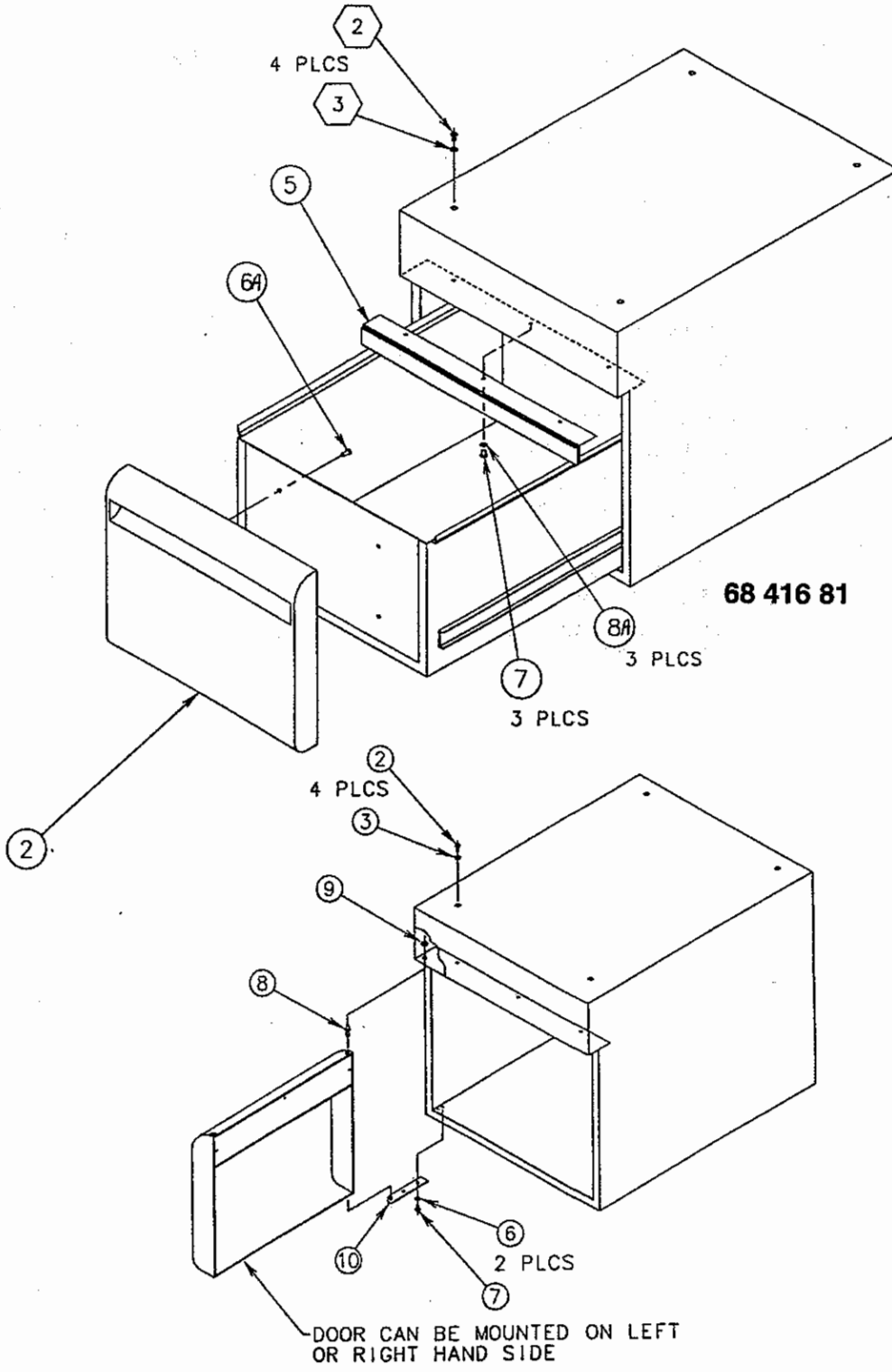

FIGURE 6.15 PARTS LOCATION DIAGRAM, INNER COLUMN ASSEMBLY

TABLE 6.15 INNER COLUMN ASSEMBLY, PARTS LIST

(Sheet 1 of 1)

ITEM NO.	REFERENCE DESIG.	DESCRIPTION	PART NUMBER
-		INNER COLUMN ASSEMBLY	68 404 40
1		COLUMN, INNER	68 405 11
2		GIB, SELF-ADJUSTING	68 405 25
3		WEDGE, GIB	68 405 27
4		SPRING, EXTENSION	68 405 29
5		BUSHING, RETAINER	68 405 31
6		LABEL, GROUND	68 212 00
7		NUT, 10-32 HX SS	99 107 00
8		NOT USED	
9		SCREW, 10-32 x 5/8 FL SK S BO	99 042 63
10		SCREW, 10-32 x 3/16 SH SL SS	99 195 02
11		LUBRICANT, DOW CORNING #111	AR
12		LOCTITE, 271	AR



68 416 80

FIGURE 6.16 PARTS LOCATION DIAGRAM, CABINET, VHA STAND

Change 5

TABLE 6.16 CABINET, VHA STAND, PARTS LIST

(Sheet 1 of 1)

ITEM NO.	REFERENCE DESIG.	DESCRIPTION	PART NUMBER
		VHA STAND CABINET	68 416 80
		VHA STAND CABINET WITH DRAWER	68 416 81
1		DOOR ASSEMBLY	68 416 87
2		SCREW, 10 - 32 X 5/8-INCH, PHILLIPS HEAD (QTY 4)	99 042 58
3		LOCK WASHER, NO. 10 (QTY 4)	99 123 94
4.			
5.		MAGNETIC CATCH ASSY	68 416 55
6		LOCK WASHER, NO. 6	99 122 20
6A		SCREW, 8 - 32 X 0.38 TR PH SS NYLOK	99 031 52
7		SCREW, 6 - 32 X 3/8-INCH, PHILLIPS HEAD (QTY 5)	99 023 31
8		PIVOT PIN	68 416 67
8A		LOCK WASHER, EXT #6	99 122 20
9		HEX NUT, 8 - 32, KEPS	99 106 32
10		HINGE PLATE	68 416 66

Change 5

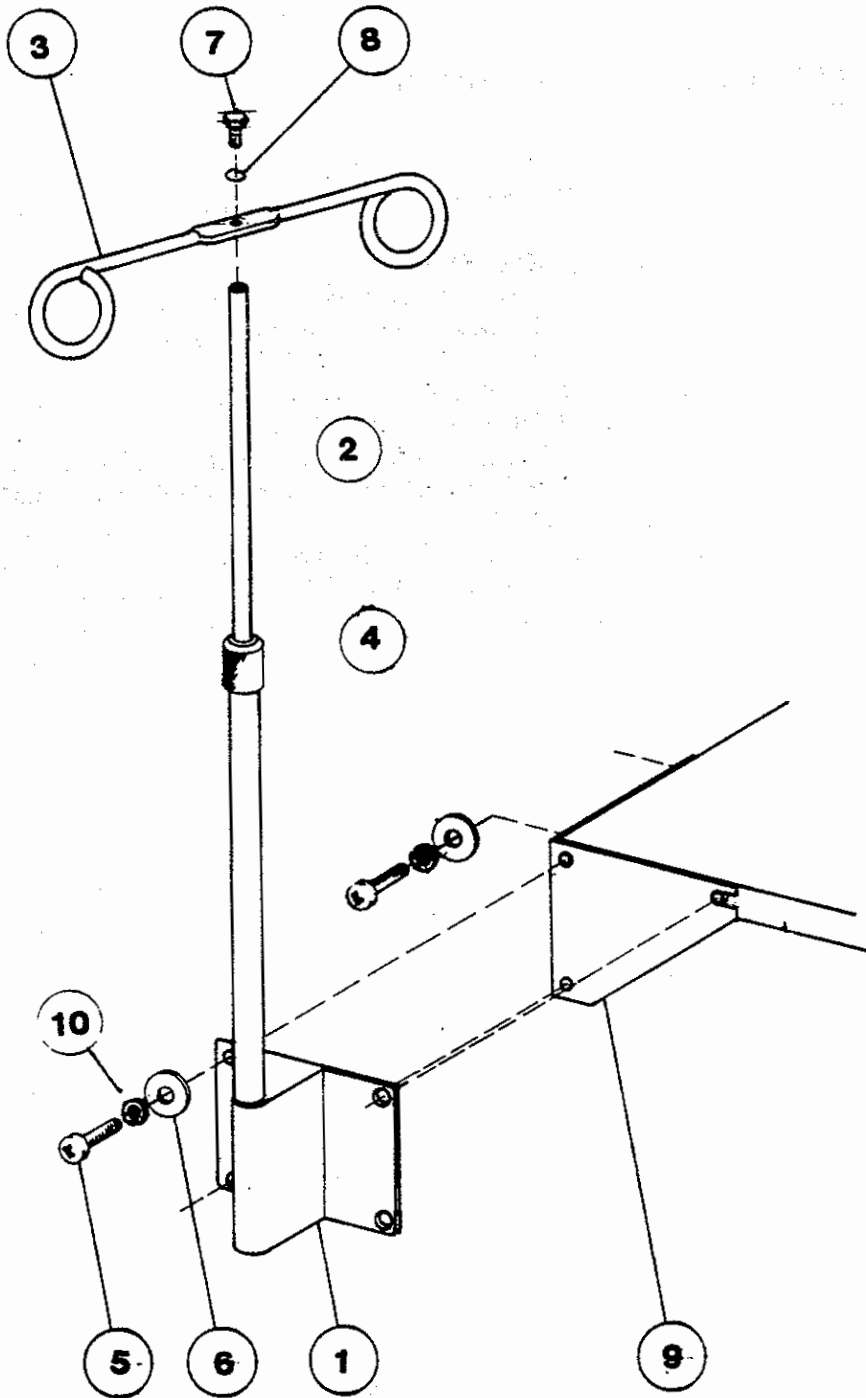
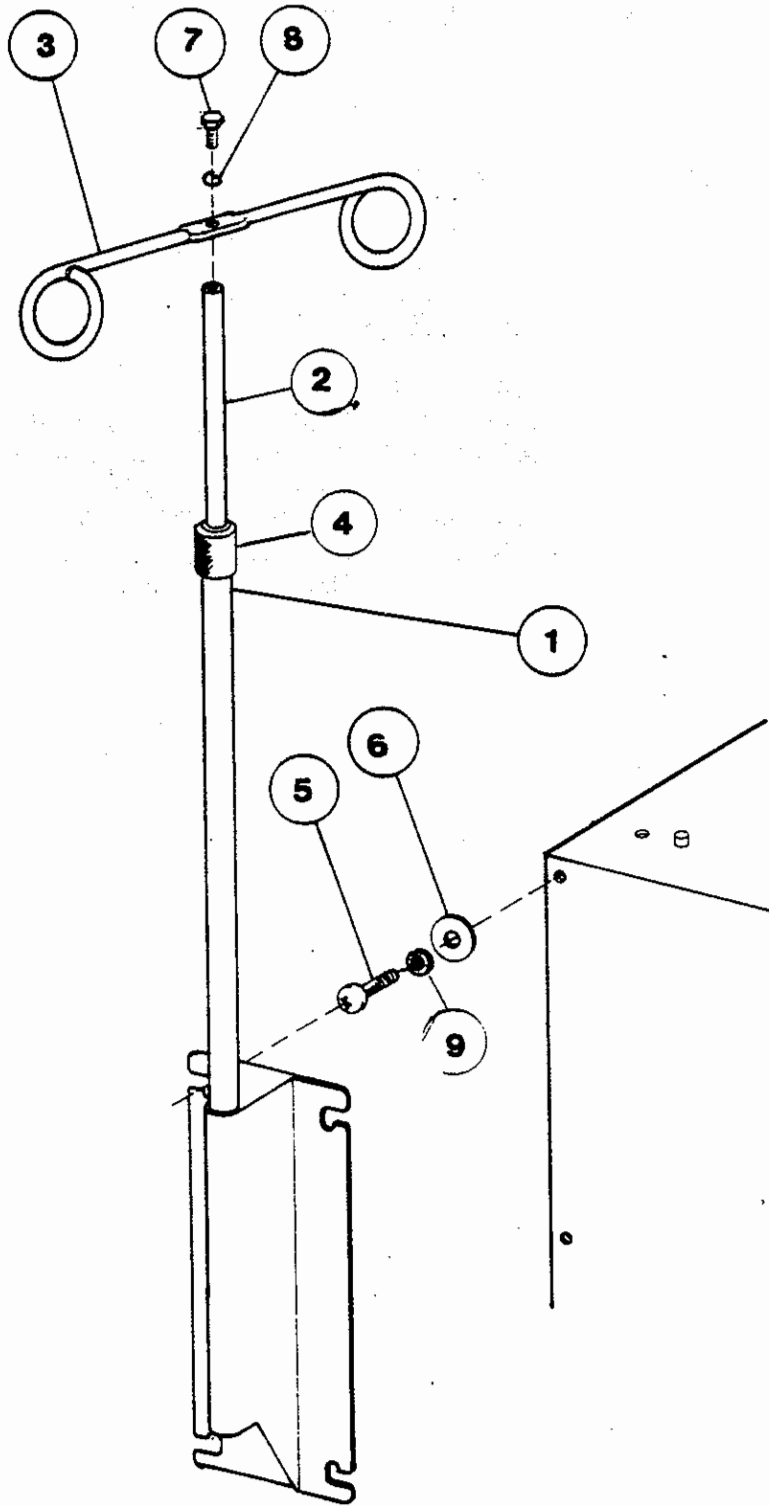

FIGURE 6.17 PARTS LOCATION DIAGRAM, I.V. POLE ASSEMBLY, VHA STAND

TABLE 6.17 I.V. POLE ASSEMBLY, VHA STAND ASSEMBLY, PARTS LISTS

(Sheet 1 of 1)

ITEM NO.	REFERENCE DESIG.	DESCRIPTION	PART NUMBER
		I.V. POLE ASSEMBLY VHA STAND	68 415 25
1		I.V. POLE BASE	68 415 26
2		UPPER EXTENSION ASSEMBLY	26 825 71
3		CROSS ARM	26 822 00
4		LOCKING NUT	26 821 00
5		SCREW, 1/4 - 20 X 3/4", PHILLIPS HEAD (QTY 5)	99 057 01
6		FLAT WASHER, 3/8" X 3/4" X 5/32" (QTY 5)	68 405 55
7		SCREW, 5/16" - 18 X 1/2", HEX HEAD	99 064 21
8		LOCK WASHER, 5/16", SMALL PATTERN	99 126 32
9		CORNER BRACKET	68 407 81
10		SPLIT LOCK WASHER, 1/4" (QTY 5)	99 125 53

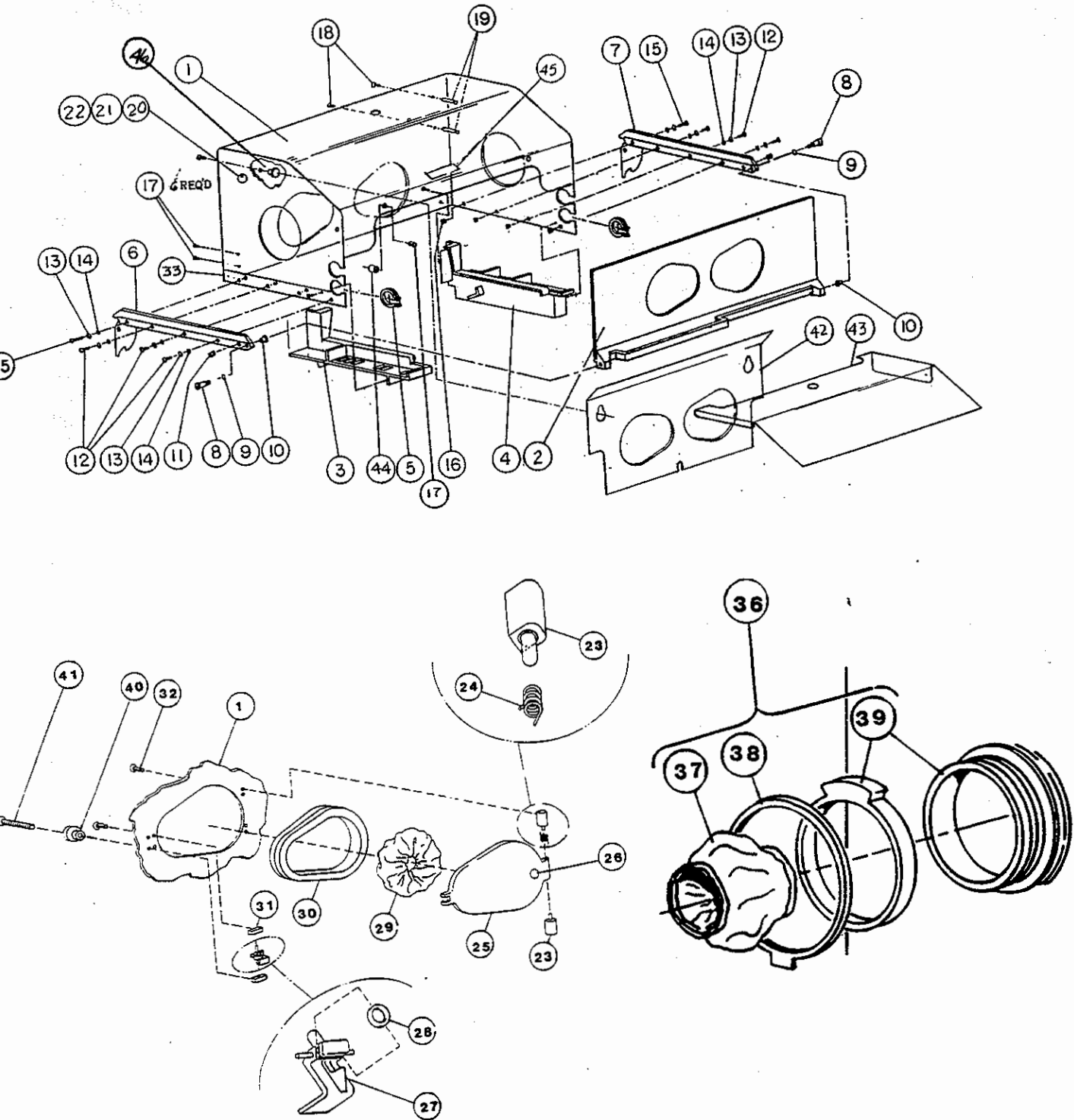

**FIGURE 6.18 PARTS LOCATION DIAGRAM, I.V. POLE ASSEMBLY, STANDARD
CABINET STAND**

**TABLE 6.18 I.V. POLE ASSEMBLY, STANDARD CABINET STAND ASSEMBLY,
PARTS LIST**

(Sheet 1 of 1)

ITEM NO.	REFERENCE DESIG.	DESCRIPTION	PART NUMBER
		I.V. POLE ASSEMBLY, STANDARD CABINET STAND	68 416 35
1	I.V. POLE BASE	68 416 36
2	UPPER EXTENSION ASSEMBLY	26 825 71
3	CROSS ARM	26 822 00
4	LOCKING NUT	26 821 00
5	SCREW, 1/4 - 20 X 5/8", PHILLIPS HEAD (QTY2)	99 056 59
6	FLAT WASHER, 1/4" X 3/4 (QTY2)	99 125 22
7	SCREW, 5/16" - 18 X 1/2", HEX HEAD	99 064 21
8	LOCK WASHER, 5/16", SMALL PATTERN	99 126 32
9	SPLIT LOCK WASHER, 1/4" (QTY 2)	99 125 53



**FIGURE 6.19 PARTS LOCATION DIAGRAM, HOOD ASSEMBLY, C500/C550 QT®
MODEL XL
Change 5**

**TABLE 6.19 HOOD ASSEMBLY, C500/C550 QT® MODEL XL,
PARTS LIST**
(Sheet 1 of 2)

ITEM NO.	REFERENCE DESIG.	DESCRIPTION	PART NUMBER
		HOOD ASSEMBLY, 3 ACCESS DOORS, 1 IRIS PORT	68 232 46
		HOOD ASSEMBLY, 2 ACCESS DOORS, 2 IRIS PORT	68 232 45
1**		HOOD, INCUBATOR (ACRYLIC ONLY)	
		3 ACCESS DOORS, 1 IRIS PORT REPL KIT ENG	68 904 30
		3 ACCESS DOORS, 1 IRIS PORT REPL KIT SPN	68 904 31
		3 ACCESS DOORS, 1 IRIS PORT REPL KIT FRN	68 904 32
		3 ACCESS DOORS, 1 IRIS PORT REPL KIT GER	68 904 33
		3 ACCESS DOORS, 1 IRIS PORT REPL KIT GER	68 904 34
		2 ACCESS DOORS, 2 IRIS PORT REPL KIT ENG	68 904 20
		2 ACCESS DOORS, 2 IRIS PORT REPL KIT SPN	68 904 21
		2 ACCESS DOORS, 2 IRIS PORT REPL KIT FRN	68 904 22
		2 ACCESS DOORS, 2 IRIS PORT REPL KIT GER	68 904 23
		2 ACCESS DOORS, 2 IRIS PORT REPL KIT GER	68 904 24
2		ACCESS PANEL ASSY (REFER TO TABLE 6.20)	
3		BAFFLE LEFT	68 156 34
4		BAFFLE RIGHT	68 156 14
5		ACCESS GROMMET	68 120 45
6		HOOD MOUNT, LEFT SIDE	68 121 15
7		HOOD MOUNT, RIGHT SIDE	68 121 05
8*		SCREW, SHOULDER SLOTTED HEAD	68 121 30
9*		WASHER, NON-METALLIC, 3/8 ID	68 121 40
10*		BEARING FLANGE, 3/8 ID	68 121 35
11*		PLUNGER SPRING	68 121 45
12		SCREW, 10 - 32 X 5/8, LG, TR, PH SS	99 042 58
13		WASHER, NO. 10, LOCK INTER, SS	99 123 92
14		WASHER, NO. 10, FLAT SS 0.062 THK	99 123 62
15		SCREW, 10 - 32, 7/8 LG, TR, PH, SS	99 043 18
16		STUD, THREADED, 10 - 32	26 301 14
17		SCREW, 6 - 32 X 7/16, TR, PH, SS	99 023 63
18		SCREW, 6 - 32 X 3/4, TR, PH, SS	99 024 69
19		HUMIDITY CARD MOUNTING STUD	68 120 41
20		THREADED STUD, 10 - 32	26 301 14
21		COVER PLATE	26 651 22
22		SCREW, 10 - 32 X 1/4	99 040 51
23		HINGE PIVOT	68 510 05
24		TORSION SPRING	68 510 10
25		DOOR ASSEMBLY	68 902 85
26		BUMPER CLR POLYURETH, SELF ADHES	78 293 10
27		ACCESS DOOR LATCH ASSEMBLY, INCLUDES ITEM 28 ...	68 902 97
28		O-RING, 3/8 DIA X 1/2 OD X 1/16 NPRN	99 160 54
29		ACCESS DOOR CUFF, REUSABLE	68 120 56
		ACCESS DOOR CUFF, DISPOSABLE	68 120 70
30		ACCESS DOOR GASKET	68 120 01
31		LATCH PIVOT	68 510 40

*Not supplied with Hood Assembly - Must be ordered separately.

**Also order Quantity 2 of Item 35 - Trim Strip

Change 5

**TABLE 6.19 HOOD ASSEMBLY, C500/C550 QT® MODEL XL,
PARTS LIST**

(Sheet 2 of 2)

ITEM NO.	REFERENCE DESIG.	DESCRIPTION	PART NUMBER
32		SCREW, 6 - 32 X 3/8 FL PH SS	99 023 39
33		WHITE PLASTIC TRIM STRIP	68 147 00
34		REINFORCING DISK	68 156 03
35		TRIM STRIP, WHITE	
		(NOT SHOWN) COVERS SCREWS OF ITEM 6	68 121 25
36		IRIS PORT ASSEMBLY	68 120 74
37		IRIS PORT SLEEVE, REUSABLE	12 615 01
		IRIS PORT SLEEVE, DISPOSABLE	26 920 70
38		RETAINING RING	68 120 32
39		RING ASSEMBLY	68 120 76
40		SMALL RETAINER KNOB	68 156 62
41		SCREW, 6 - 32 X 1.12 TR PH SS NYLOCK	99 025 44
42		HEAT SHIELD ASSY (REAR) REPL KIT	68 904 08
43		HEAT SHIELD ASSY (TOP) REPL KIT	68 904 14
44		SPACER, 6 - 32 , 0.38 OD X 0.44 LG	68 232 24
45		NO FILTER COVER WARNING LABEL	68 115 40
46		RETAINER KNOB, 0.75 OD X 0.66 LG	68 232 25

Change 6

(This page is intentionally left blank.)

Change 4

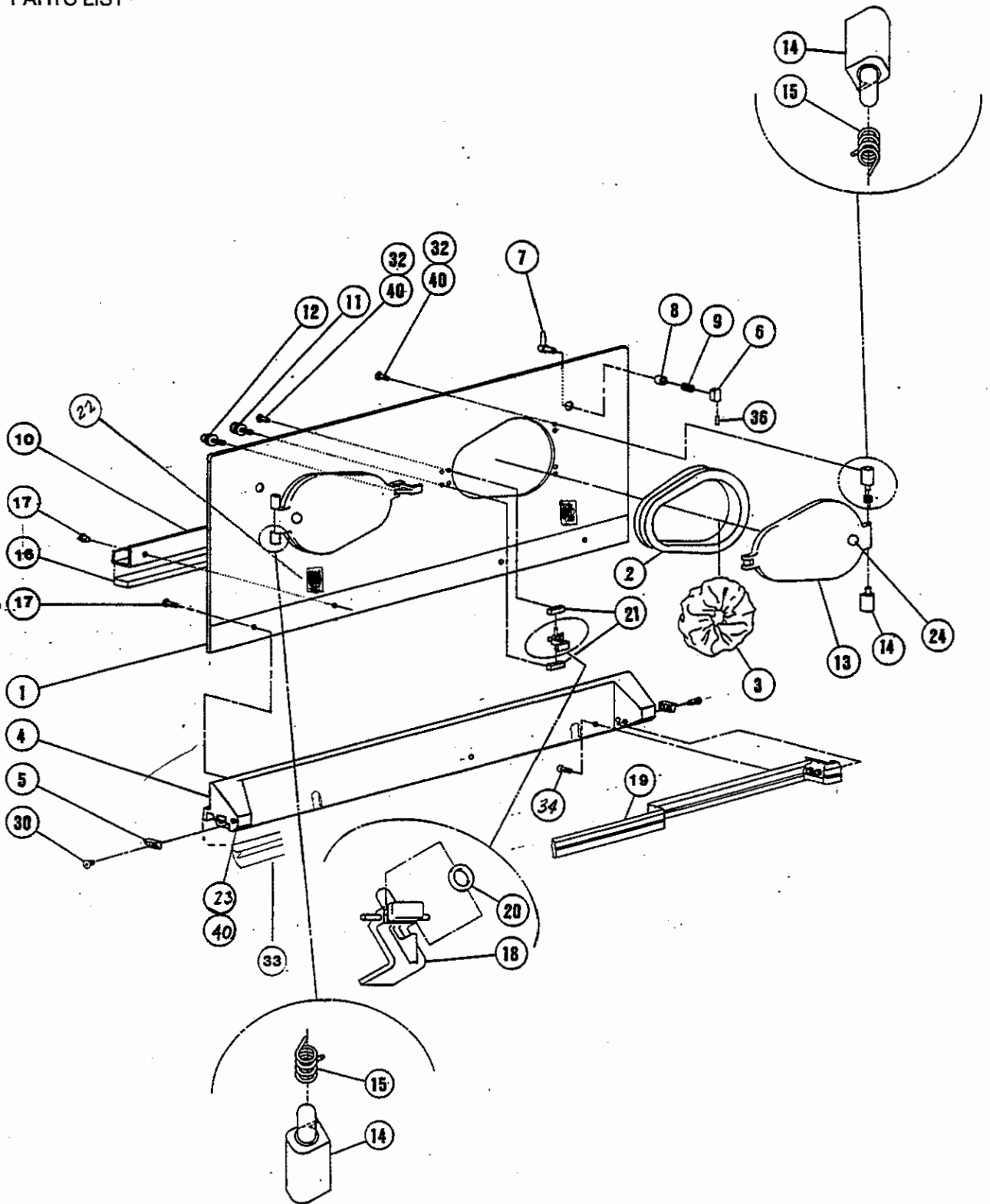

**FIGURE 6.20 PARTS LOCATION DIAGRAM, ACCESS PANEL ASSEMBLY,
C500/C550 QT® MODEL XL**

Change 6

TABLE 6.20 ACCESS PANEL ASSEMBLY, C500/C550 QT® MODEL XL,PARTS LIST
(Sheet 1 of 1)

ITEM NO.	REFERENCE DESIG.	DESCRIPTION	PART NUMBER
		ACCESS PANEL ASSY WITH CUFFS PNEUMATIC, PINK HANDLE	68 232 40
		ACCESS PANEL ASSY WITHOUT CUFFS PNEUMATIC, PINK HANDLE	68 232 41
		ACCESS PANEL ASSY WITH CUFFS PNEUMATIC, BLUE HANDLE	68 232 42
		ACCESS PANEL ASSY WITH CUFFS MANUAL	68 232 43
1		PANEL, ACCESS, REPLACEMENT KIT, (INCLUDES ITEMS 6,7,8,9,36,38, 39 AND 41) ENG	68 904 90
		SPANISH	68 904 91
		FRENCH	68 904 92
		GERMAN	68 904 93
		ITALIAN	68 904 94
2		ACCESS DOOR GASKET	68 120 01
3		CUFF, ACCESS DOOR	68 120 56
4		BEZEL, ACCESS PANEL PNEUMATIC TILT	68 232 23
		BEZEL, ACCESS PANEL MANUAL TILT	68 232 28
5		PLATE, STRIKER	68 121 55
6		REFER TO ITEM 37	
7		REFER TO ITEM 37	
8		REFER TO ITEM 37	
9		REFER TO ITEM 37	
10		DECK CLOSE OFF BRACKET	68 232 19
11		KNOB, RETAINER, LARGE	68 156 61
12		KNOB, RETAINER, SMALL	68 156 60
13		DOOR, ASSEMBLY	68 902 85
14		PIVOT, HINGE	68 510 05
15		SPRING, TORSION	68 510 10
16		DECK CLOSE OFF BRACKET GASKET	68 232 15
17		SCREW, 8 - 32 X 7/16 TR PH SS	68 121 31
18		LATCH ASSY, ACCESS DOOR INCLUDES ITEM 20	68 510 26
19		HANDLE ASSY, PINK	68 506 42
20		O RING, 3/8 ID x 1/2 OD x 1/16, NPRN	99 160 54
21		PIVOT, LATCH	68 510 40
22		MATTRESS TRAY STOP	68 157 30
23		WHITE VINYL GASKET, PNEUMATIC TILT ONLY	68 232 16
24		BUMPER, CLR POLYURETH, SELF ADH	78 293 10
25		SPACER, 1/2 OD X 0.166 ID X 3/8 LG	68 156 66
27		NOT USED	
28		ADHESIVE, CYACRLT, L0C 404/EAST 910	AR
29		ADHESIVE, CLEAR 3M4693	AR
30		SCREW, 6-32 x 1/2 FL PH SS	99 023 94
32		SCREW, 6-32 x 7/8 NYLOK	99 023 64
33		WHITE VINYL GASKET 0.25 W X 17 LG, MANUAL TILT	68 234 02
		WHITE VINYL GASKET 0.25 W X 7 LG (QTY 2), MANUAL TILT	68 234 03
34		SCREW, 6- 32 X 3/8	99 023 39
35		NOT USED	
36		REFER TO ITEM 37	
37		PAWL LATCH REPLACEMENT KIT	68 902 96
38		PINK QT/ ANIMALS LABEL	68 512 36
39		WARNING; INFANT SAFETY LABEL	68 501 20
40		COMPOUND, RTV SILICONE RUBBER, CLR	AR
41		PATENT PENDING LABEL	68 512 13

Change 7

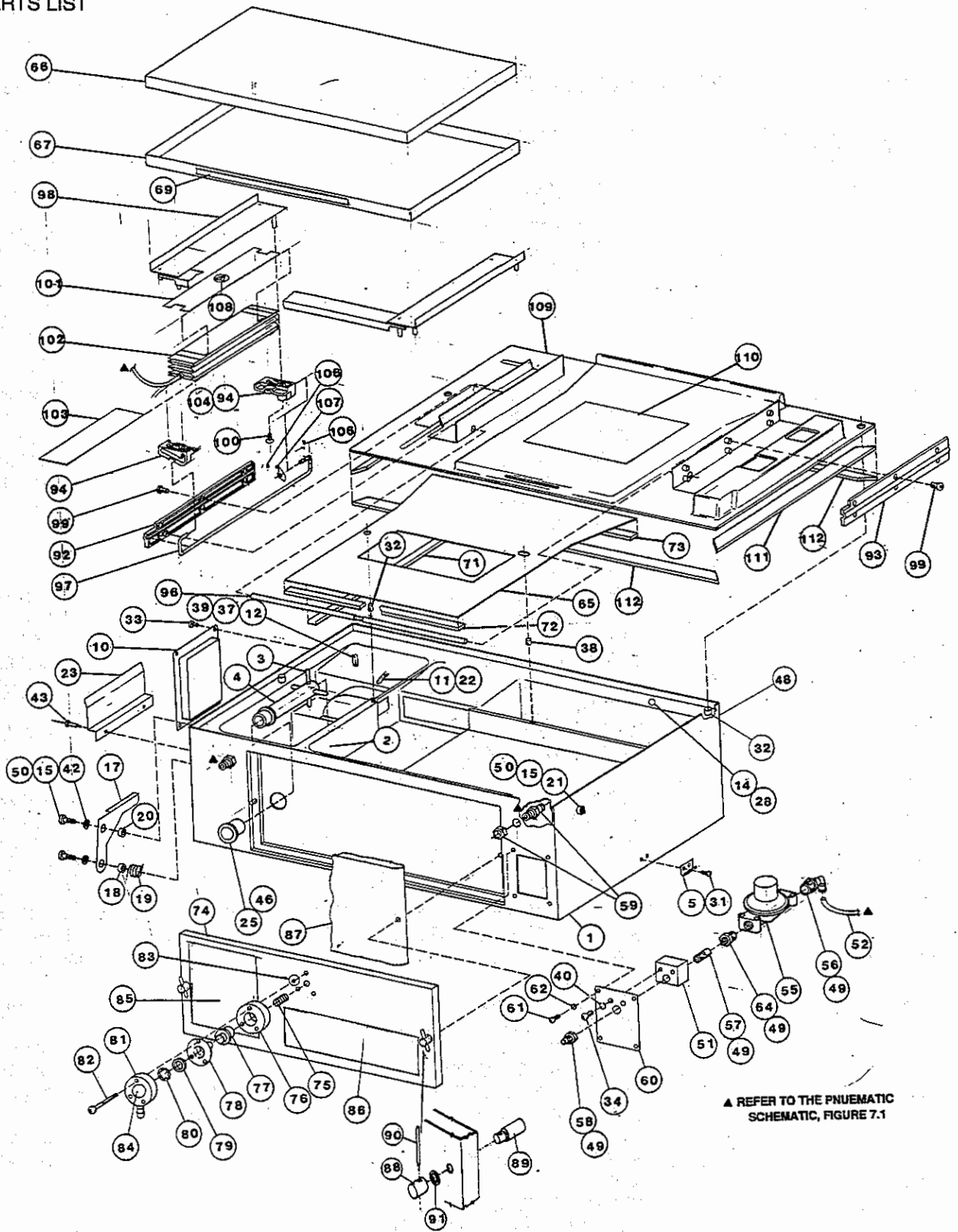

FIGURE 6.21 PARTS LOCATION DIAGRAM, SHELL AND PNEUMATIC TILT DECK ASSEMBLY, C500/C550 QT® MODEL XL

Change 4

**TABLE 6.21 SHELL AND PNEUMATIC TILT DECK ASSEMBLY, C500/C550 QT®
MODEL XL, PARTS LIST**

(Sheet 1 of 4)

ITEM NO.	REFERENCE DESIG.	DESCRIPTION	PART NUMBER
1		SHELL	68 552 00
2		CASTING	26 100 50
3		PIN CROSS FEED PIPE	68 231 01
4		CROSS FEED PIPE	68 232 04
5		LATCH HOOK	24 144 01
6		NOT USED	
7		NOT USED	
8		NOT USED	
9		NOT USED	
10		RECESSED OUTLET PANEL	68 500 15
		RECESSED OUTLET PANEL LABEL - JAPANESE	68 500 36
11		GROUNDING SPRING	68 400 27
12		RAMP LATCH	68 110 42
13		NOT USED	
14		SCREW, 8 - 32 3/8	99 031 37
15		SLOTTED SHOULDER SCREW	68 110 51
16		NOT USED	
17		LATCH HANDLE	68 110 55
18		SPACER NON-METALLIC	68 110 56
19		TORSION SPRING	68 110 57
20		SPACER NON - METALLIC	68 110 58
21		SPACER NON-METALLIC	68 110 59
22		HEX NUT, 6-32 KEPS	99 105 34
23		POWER CORD DUCT	68 507 15
24		NOT USED	
25		FILTER GROMMET	68 112 15
26		NOT USED	
27		NOT USED	
28		WHITE, R TV	AR
29		NOT USED	
30		NOT USED	
31		SCREW, 4 - 40 X 5/16 FL PH SS	99 017 77
32		DELTRAN SCREW, 10 - 24 X 0.25 X 0.165	68 232 02
33		SCREW, 4 - 40 X 5/16 TR PH SS	99 010 76
34		SCREW, 10 - 32 X 1/2 TR PH SS	99 042 01
35		SCREW, 8 - 32 X 3/8 RD PH SS	99 031 37
36		NOT USED	
37		HEX NUT, 8 -32 SS	99 106 01
38		DELTRAN SCREW, 10 - 24 X 0.25 X 0.437	68 232 03
39		LOCK WASHER, #8	99 122 95
40		LOCK WASHER #10	99 124 16

Change 7

**TABLE 6.21 SHELL AND PNEUMATIC TILTDECK ASSEMBLY, C500/C550 QT®
MODEL XL, PARTS LIST**

(Sheet 2 of 4)

ITEM NO.	REFERENCE DESIG.	DESCRIPTION	PART NUMBER
41		NOT USED	
42		WASHER, 0.38 OD X 0.62 ID	99 126 70
43		POP RIVET, 1/8 D LG FLANGE	99 131 70
44		BEZEL LABEL, JAPANESE	68 504 15
45		O-RING 5/8 X 3/4 X 1/16	99 161 04
46		DOW CORNING LUBE #111	AR
47		WHITE RTV COMPOUND	AR
48		BEZEL ASSY (REFER TO FIGURE 7.1)	68 504 70
49		TEFLON PIPE SEALANT	AR
50		LOCTITE #222	AR
51		AIR SUPPLY MANIFOLD	68 504 33
52		CLEAR TUBING 20" LONG 0.250 OD (REFER TO THE PNEUMATIC SCHEMATIC FIGURE 7.1)	68 505 11
53		BLUE TUBING 22" LONG 0.250 OD (REFER TO THE PNEUMATIC SCHEMATIC FIGURE 7.1)	68 505 21
54		RED TUBING 37" LONG 0.250 OD (REFER TO THE PNEUMATIC SCHEMATIC FIGURE 7.1)	68 505 31
55		REGULATOR, 2.1 PSIG PRESET	68 504 49
56		TUBING FITTING, MALE ELBOW	68 504 01
57		MUFFLER/FILTER ELEMENT, 1/8 NPT	68 504 45
58		AIR-IN VALVE, MALE DISS	78 435 26
59		TUBING FITTING, BLKHD UNION	68 504 19
60		REGULATOR MOUNTING PLATE	68 507 10
61		SCREW, 6 - 32 X 3/8 TR PH SS	99 023 31
62		LOCK WASHER SP #6	99 122 16
63		TIE WRAPS FOR TUBING (NOT SHOWN)	12 995 00
64		REDUCER BUSHING, 1/4 NPT X 1/8 FNPT	68 504 09
65		INNER DECK PLATE (INCLUDES 71, 72 AND 72)	68 904 80
66		MATTRESS	68 142 71
67		MATTRESS TRAY ASSY ENG (INCLUDES ITEM 69)	68 904 00
		MATTRESS TRAY ASSY SPN	68 904 01
		MATTRESS TRAY ASSY FRN	68 904 02
		MATTRESS TRAY ASSY GER	68 904 03
		MATTRESS TRAY ASSY ITL	68 904 04
68		NOT USED	
69		MATTRESS TRAY WARNING ENG	68 160 30
		MATTRESS TRAY WARNING LABEL SPN	68 160 31
		MATTRESS TRAY WARNING LABEL FRN	68 160 32
		MATTRESS TRAY WARNING LABEL GER	68 160 33
		MATTRESS TRAY WARNING LABEL ITL	68 160 34
70		NOT USED	
71		GASKET, 1/2 W X 15.5 LG	68 232 48

Change 4

**TABLE 6.21 SHELL AND PNEUMATIC TILT DECK ASSEMBLY, C500/C550 QT®
MODEL XL, PARTS LIST**

(Sheet 3 of 4)

ITEM NO.	REFERENCE DESIG.	DESCRIPTION	PART NUMBER
72		GASKET, 1/2 W X 13.84 LG	68 232 47
73		GASKET, 1/2 W X 17 LG	68 232 49
74		FILTER COVER ASSEMBLY, ENG (INCLUDES ITEM 75 THRU 88)	68 507 40
		FILTER COVER ASSEMBLY, SPN (INCLUDES ITEM 75 THRU 88)	68 507 41
		FILTER COVER ASSEMBLY, FRN (INCLUDES ITEM 75 THRU 88)	68 507 42
		FILTER COVER ASSEMBLY, GER (INCLUDES ITEM 75 THRU 88)	68 507 43
		FILTER COVER ASSEMBLY, ITL (INCLUDES ITEM 75 THRU 88)	68 507 44
75		COMPRESSION SPRING	68 130 65
76		CYLINDER	68 130 55
77		FILTER CARTRIDGE	68 130 67
78		DIAPHRAGM	68 130 57
79		NON-METALLIC WASHER	68 130 51
80		RETAINING RING, WAL 5105-62 SS	99 182 93
81		CAP	68 130 60
82		SCREW, 6- 32 X 1.75" OV PH SS	99 026 18
83		NON-METALLIC WASHER	68 130 52
84		OXYGEN LIMITER LABEL, ENG	68 133 35
		OXYGEN LIMITER LABEL, SPN	68 133 36
		OXYGEN LIMITER LABEL, FRN	68 133 37
		OXYGEN LIMITER LABEL, GER	68 133 38
		OXYGEN LIMITER LABEL, ITL	68 133 34
85		OXYGEN CONCENTRATION LABEL, ENG	68 133 10
		OXYGEN CONCENTRATION LABEL, SPN	68 133 11
		OXYGEN CONCENTRATION LABEL, FRN	68 133 12
		OXYGEN CONCENTRATION LABEL, GER	68 133 13
		OXYGEN CONCENTRATION LABEL, ITL	68 133 15
86		FILTER COVER LABEL, ENG	26 330 60
		FILTER COVER LABEL, SPN	26 330 61
		FILTER COVER LABEL, FRN	26 330 62
		FILTER COVER LABEL, GER	26 330 63
		FILTER COVER LABEL, ITL	26 330 64
87		AIR FILTER (BOX OF 4)	26 945 70
88		FILTER COVER KNOB	68 130 30
89		FILTER COVER KNOB SHAFT	68 130 35
90		FILTER COVER KNOB HANDLE	68 130 40
91		WASHER, 0.38 ID X 0.62 OD X 0.15 THK NYLON	99 126 11

Change 4

**TABLE 6.21 SHELL AND PNEUMATIC TILT DECK ASSEMBLY, C500/C550 QT®
MODEL XL, PARTS LIST**

(Sheet 4 of 4)

ITEM NO.	REFERENCE DESIG.	DESCRIPTION	PART NUMBER
92		RIGHT DECK RAIL	68 504 30
93		LEFT DECK RAIL	68 504 37
94		RIGHT DECK RETAINER (WITHOUT PIN)	68 504 34
95		LEFT DECK RETAINER (WITHOUT PIN)	68 504 35
96		NOT USED	
97		MATTRESS TRAY STABILIZER BAR	68 504 36
98		TRAY SUPPORT	68 504 38
99		SCREW, 4 - 40 X 1/4" TR PH SS NYLOC	99 010 67
100		SCREW, 4 - 40 X 1/2" TR PH SS NYLOC	99 011 63
101		BELLOWS TOP PLATE (INCLUDES LABEL, ITEM 108)	68 901 20
102		BELLOWS	68 504 29
103		BELLOWS BOTTOM PLATE	68 504 28
104		STABILIZER BAR RETAINER RIGHT-HAND WITH PIN	68 504 65
105		STABILIZER BAR RETAINER LEFT-HAND WITH PIN (NOT SHOWN)	68 504 66
106		RETAINING RING	99 181 47
107		LOCK-UP CLIP	68 504 44
108		LABEL, MANUAL REFERENCE SYMBOL (INCLUDED WITH ITEM 101)	68 160 05
109		MAIN DECK ASSEMBLY (INCLUDES 110, 111 AND 112)	68 904 50
110		CORRECT OPERATION LABEL	68 234 10
111		MAIN DECK GASKET, 16-INCHES LONG	68 232 30
112		MAIN DECK GASKET, 33-INCHES LONG	68 323 31

Change 4

(This page is intentionally left blank.)



Change 4

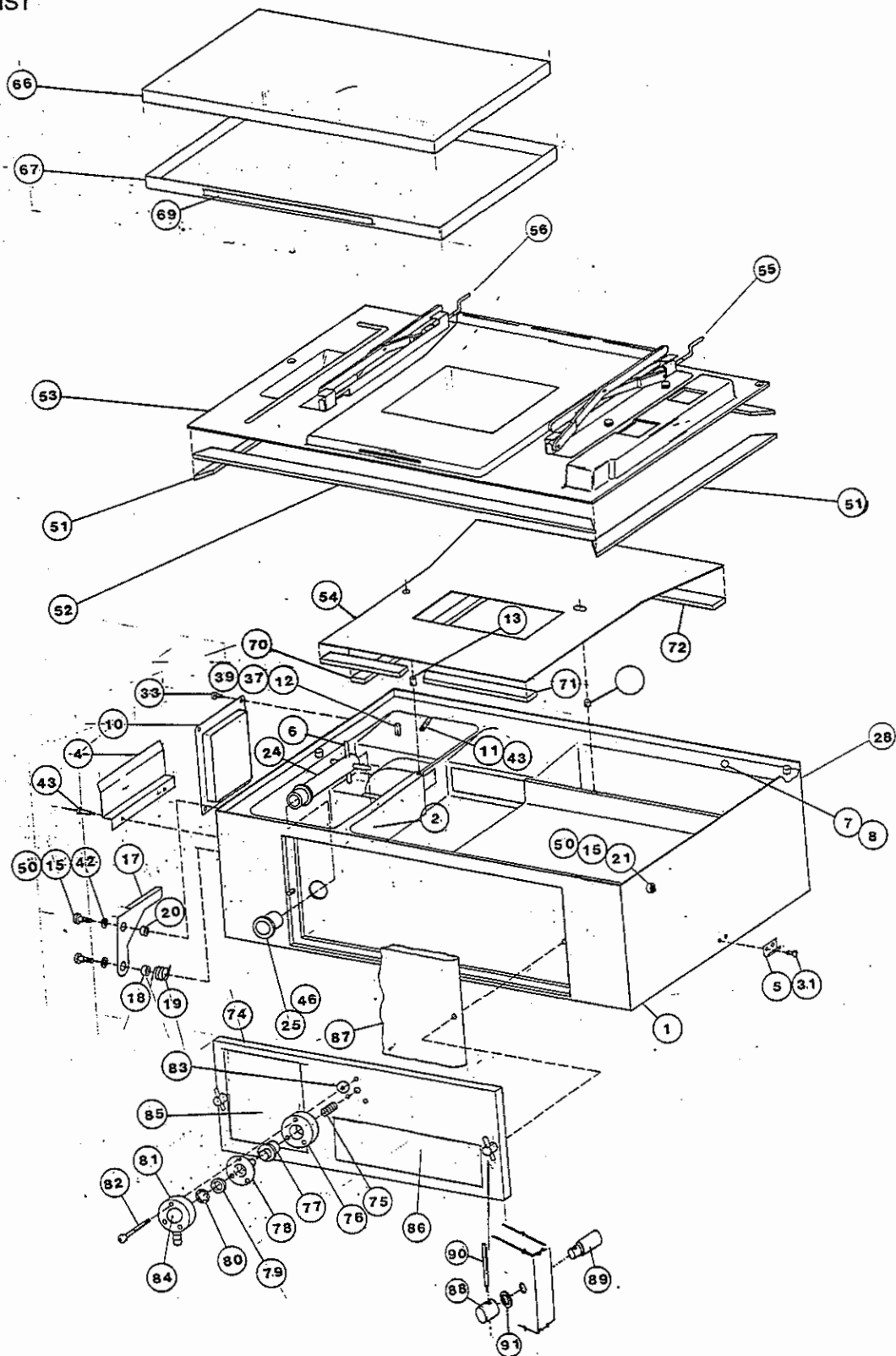

FIGURE 6.22 PARTS LOCATION DIAGRAM, SHELL AND MANUAL TILT DECK ASSEMBLY, C500/C550 QT® MODEL XL

Change 4

**TABLE 6.22 SHELL AND MANUAL TILT DECK ASSEMBLY, C500/C550 QT®
MODEL XL, PARTS LIST**

(Sheet 1 of 3)

ITEM NO.	REFERENCE DESIG.	DESCRIPTION	PART NUMBER
1		SHELL	68 507 00
2		CASTING	26 100 50
3		NOT USED	
4		POWER CORD DUCT	68 507 15
5		LATCH HOOK	24 144 01
6		DOWEL PIN, CROSS FEED PIPE	99 143 99
7		SCREW, 8 - 32 X 3/8 RD PH SS	99 031 37
8		WHITE RTV	AR
9		NOT USED	
10		RECESSED OUTLET PANEL	68 500 15
		RECESSED OUTLET PANEL LABEL - C500, 120V ENG	68 500 20
		RECESSED OUTLET PANEL LABEL - C500, 120V SPN	68 500 21
		RECESSED OUTLET PANEL LABEL - C500, 120V FRN	68 500 22
		RECESSED OUTLET PANEL LABEL - C500, 220V GER	68 500 23
		RECESSED OUTLET PANEL LABEL - C500, 220/240V ENG	68 500 24
		RECESSED OUTLET PANEL LABEL - C500, 220/240V ITL	68 500 25
		RECESSED OUTLET PANEL LABEL - C500, 220/240V SPN	68 500 27
		RECESSED OUTLET PANEL LABEL - C500, 220/240V FRN	68 500 28
		RECESSED OUTLET PANEL LABEL - C550, 120V ENG	68 500 30
		RECESSED OUTLET PANEL LABEL - C550, 120V SPN	68 500 31
		RECESSED OUTLET PANEL LABEL - C550, 120V FRN	68 500 32
		RECESSED OUTLET PANEL LABEL - C550, 220V GER	68 500 33
		RECESSED OUTLET PANEL LABEL - C550, 220/240V ENG	68 500 34
		RECESSED OUTLET PANEL LABEL - C550, 220/240V ITL	68 500 35
		RECESSED OUTLET PANEL LABEL - C550, 220/240V SPN	68 500 37
		RECESSED OUTLET PANEL LABEL - C550, 220/240V FRN	68 500 38
11		LEAF SPRING	68 110 41
12		RAMP LATCH	68 110 42
13		DELTRAN SCREW, 10-32 X 0.25 X 0.165	68 232 02
14		FILL SPOUT STOP	68 110 50
15		SLOTTED SHOULDER SCREW	68 110 52
16		NOT USED	
17		LATCH HANDLE	68 110 55
18		SPACER NON-METALLIC	68 110 56
19		TORSION SPRING	68 110 57
20		SPACER NON-METALLIC	68 110 58
21		SPACER NON-METALLIC	68 110 59
22		DELTRAN SCREW, 10 - 24 X 0.25 X 0.437	68 232 03
23		NOT USED	
24		CROSS FEED PIPE	68 112 04
25		FILTER GROMMET	68 112 15
26		NOT USED	
27		DECK RETAINING KNOB REPL KIT	68 901 22

Change 7

**TABLE 6.22 SHELL AND MANUAL TILT DECK ASSEMBLY, C500/C550 QT®
MODEL XL, PARTS LIST**

(Sheet 2 of 3)

ITEM NO.	REFERENCE DESIG.	DESCRIPTION	PART NUMBER
28		MANUAL TILT BEZEL ASSEMBLY	68 504 75
29		NOT USED	
30		NOT USED	
31		SCREW, 4 – 40 X 5/16 FL PH SS	99 010 77
32		THUMB SCREW, 4 – 40 X 1/4	99 010 63
33		SCREW, 4 – 40 X 5/16 TR PH SS	99 010 76
34		NOT USED	
35		SCREW, 8 – 32 X 3/8 RD PH SS	99 031 37
36		NOT USED	
37		HEX NUT, 8 –32 SS	99 106 01
38			
39		LOCK WASHER, #8	99 122 95
40		MAIN DECK MANUAL TILT (REFER TO TABLE 6.6)	
41		WASHER, 0.560 OD X 0.25 ID PLASTIC	99 125 57
42		WASHER, 0.38 OD X 0.62 ID	99 126 70
43			
44		PIN, 1/8 DIA X 1 1/2 LG SS	99 143 96
45		O-RING 5/8 X 3/4 X 1/16	99 161 04
46		DOW CORNING LUBE #111	AR
47		WHITE RTV COMPOUND	AR
48		NOT USED	
49		NOT USED	
50		LOCTITE #222	AR
51		MAIN DECK GASKET 13-INCHES LONG	68 232 30
52		MAIN DECK GASKET 16-INCHES LONG	68 232 31
53		MAIN DECK ASSEMBLY (INCLUDES ITEMS 51, 52 AND 63)	68 904 60
54		INNER DECK	68 904 80
55		ELEVATOR ASSY RIGHT HAND	68 521 47
56		ELEVATOR ASSY LEFT HAND	68 521 48
63		CORRECT OPERATION LABEL	68 234 10
64		REDUCER BUSHING, 1/4 NPT X 1/8 FNPT	68 504 09
65		NOT USED	
66		MATTRESS	68 142 71
67		MATTRESS TRAY ASSY ENG (INCLUDES ITEM 69)	68 901 00
		MATTRESS TRAY ASSY SPN	68 901 01
		MATTRESS TRAY ASSY FRN	68 901 02
		MATTRESS TRAY ASSY GER	68 901 03
		MATTRESS TRAY ASSY ITL	68 901 04
69		MATTRESS TRAY WARNING LABEL ENG	68 160 30
		MATTRESS TRAY WARNING LABEL SPN	68 160 31
		MATTRESS TRAY WARNING LABEL FRN	68 160 32
		MATTRESS TRAY WARNING LABEL GER	68 160 33
		MATTRESS TRAY WARNING LABEL ITL	68 160 34

Change 4

**TABLE 6.22 SHELL AND MANUAL TILT DECK ASSEMBLY, C500/C550 QT®
MODEL XL, PARTS LIST**

(Sheet 3 of 3)

ITEM NO.	REFERENCE DESIG.	DESCRIPTION	PART NUMBER
70		GASKET, 1/2 W X 15.5 LG	68 232 48
71		GASKET, 1/2 W X 13.84 LG	68 232 49
72		GASKET, 1/2 W X 17 LG	68 232 49
73		NOT USED	
74		FILTER COVER ASSEMBLY, ENG (INCLUDES ITEM 75 THRU 88)	68 507 40
		FILTER COVER ASSEMBLY, SPN (INCLUDES ITEM 75 THRU 88)	68 507 41
		FILTER COVER ASSEMBLY, FRN (INCLUDES ITEM 75 THRU 88)	68 507 42
		FILTER COVER ASSEMBLY, GER (INCLUDES ITEM 75 THRU 88)	68 507 43
		FILTER COVER ASSEMBLY, ITL (INCLUDES ITEM 75 THRU 88)	68 507 44
75		COMPRESSION SPRING	68 130 65
76		CYLINDER	68 130 55
77		FILTER CARTRIDGE	68 130 67
78		DIAPHRAGM	68 130 57
79		NON-METALLIC WASHER	68 130 51
80		RETAINING RING, WAL 5105-62 SS	99 182 93
81		CAP	68 130 60
82		SCREW, 6- 32 X 1.75" OV PH SS	99 026 18
83		NON-METALLIC WASHER	68 130 52
84		OXYGEN LIMITER LABEL, ENG	68 133 35
		OXYGEN LIMITER LABEL, SPN	68 133 36
		OXYGEN LIMITER LABEL, FRN	68 133 37
		OXYGEN LIMITER LABEL, GER	68 133 38
		OXYGEN LIMITER LABEL, ITL	68 133 34
85		OXYGEN CONCENTRATION LABEL, ENG	68 133 10
		OXYGEN CONCENTRATION LABEL, SPN	68 133 11
		OXYGEN CONCENTRATION LABEL, FRN	68 133 12
		OXYGEN CONCENTRATION LABEL, GER	68 133 13
		OXYGEN CONCENTRATION LABEL, ITL	68 133 15
86		FILTER COVER LABEL, ENG	26 330 60
		FILTER COVER LABEL, SPN	26 330 61
		FILTER COVER LABEL, FRN	26 330 62
		FILTER COVER LABEL, GER	26 330 63
		FILTER COVER LABEL, ITL	26 330 64
87		AIR FILTER (BOX OF 4)	26 945 70
88		FILTER COVER KNOB	68 130 30
89		FILTER COVER KNOB SHAFT	68 130 35
90		FILTER COVER KNOB HANDLE	68 130 40
91		WASHER, 0.38 ID X 0.62 OD X 0.15 THK NYLON	99 126 11

Change 5

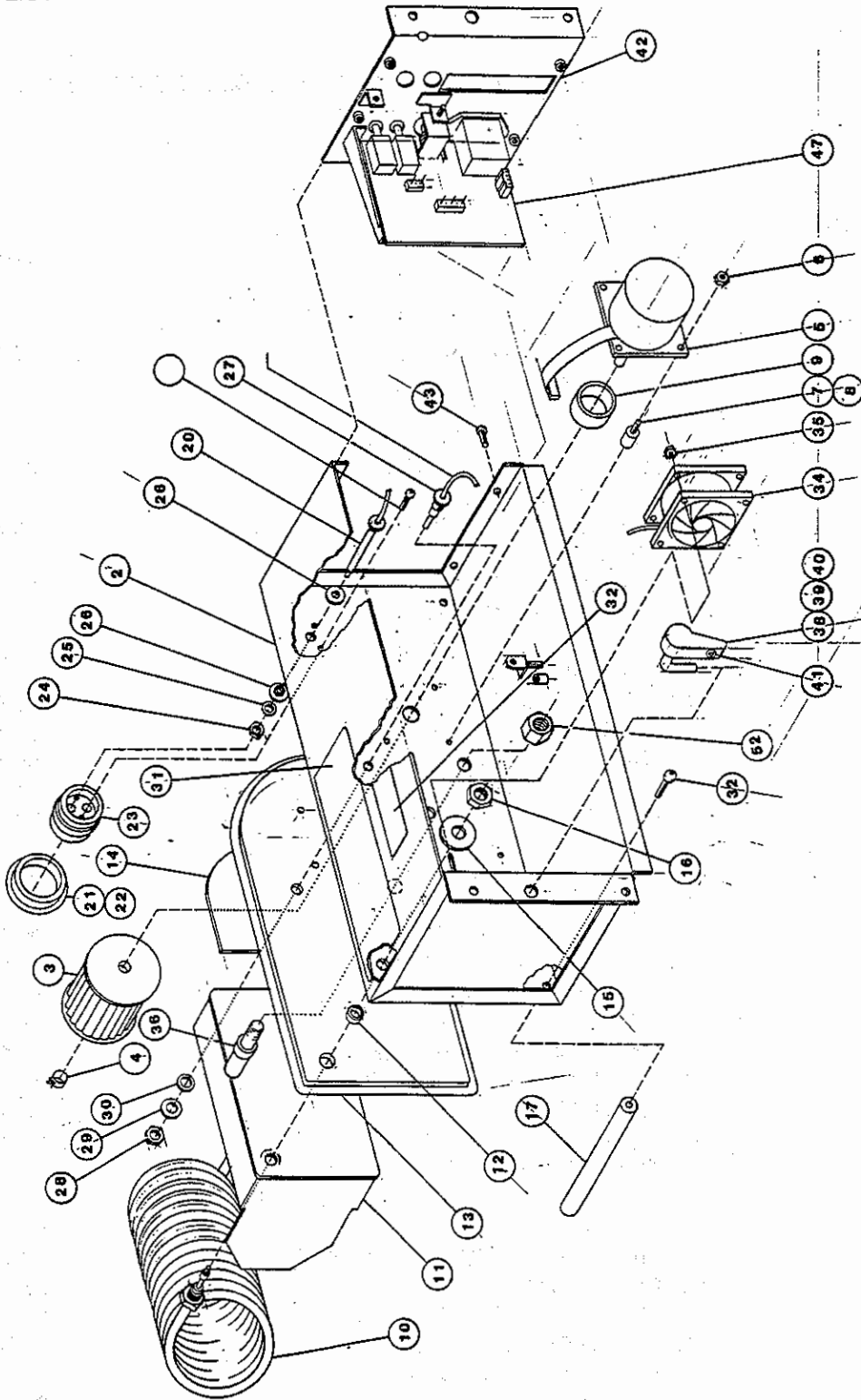

**FIGURE 6.23 PARTS LOCATION DIAGRAM, CONTROLLER ASSEMBLY
C500/550 QT® MODEL XL (SHEET 1 OF 3)**

Change 4

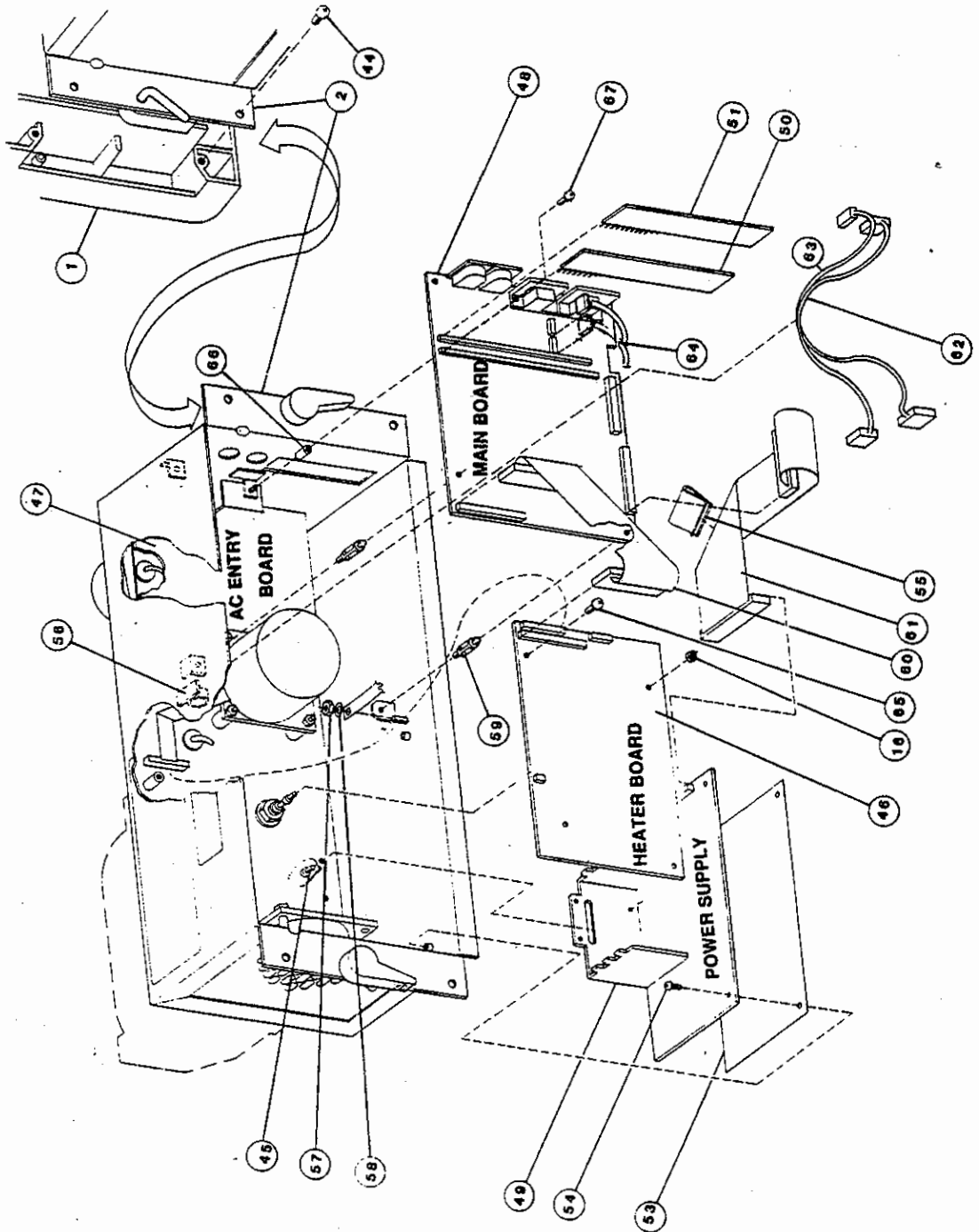

**FIGURE 6.23 PARTS LOCATION DIAGRAM, CONTROLLER ASSEMBLY
C500/550 QT® MODEL XL (SHEET 2 OF 3)**

Change 4

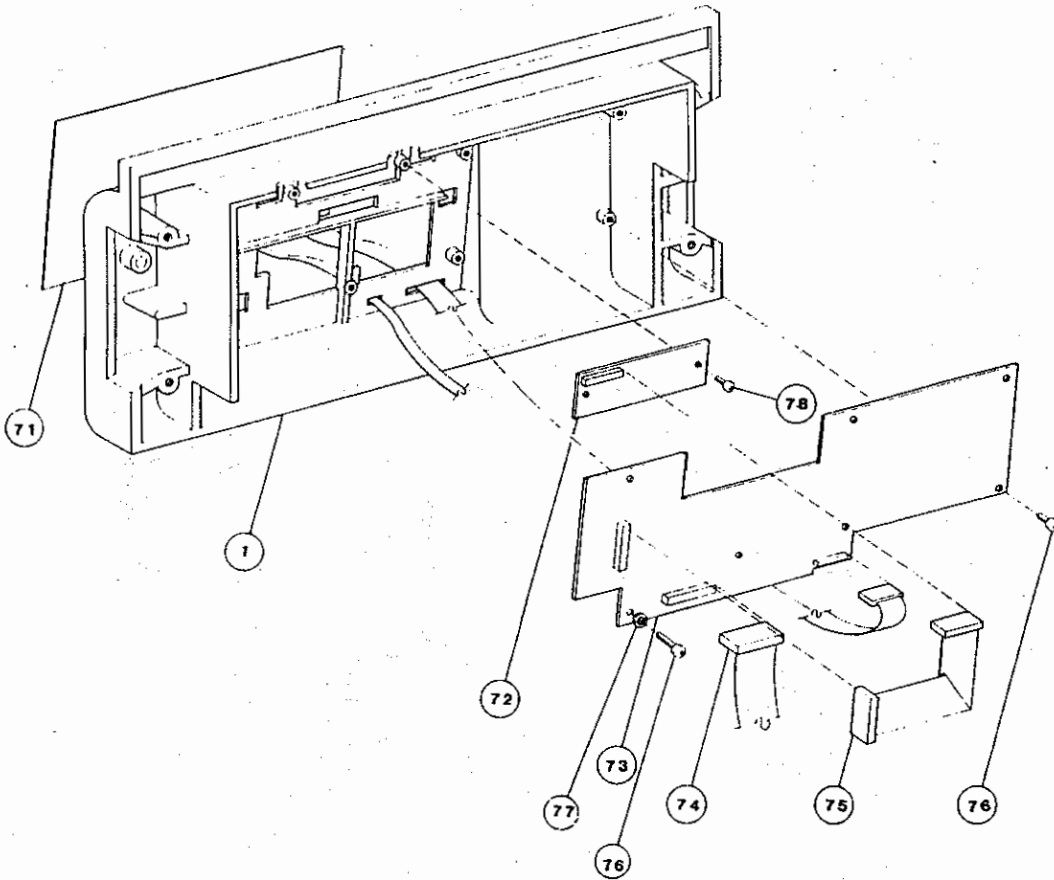

**FIGURE 6.23 PARTS LOCATION DIAGRAM, CONTROLLER ASSEMBLY
C500/550 QT® MODEL XL (SHEET 3 OF 3)**

Change 4

TABLE 6.23 CONTROLLER ASSEMBLY, C500/550 QT® XL, PARTS LIST

(Sheet 1 of 3)

ITEM NO.	REFERENCE DESIG.	DESCRIPTION	PART NUMBER
		CONTROLLER, C500 XL 120V ENG	68 234 70
		CONTROLLER, C500 XL 240V INT	68 234 80
		CONTROLLER, C550 XL 120V ENG	68 233 70
		CONTROLLER, C550 XL 240V INT	68 233 80
		CONTROLLER, C550 XL 100V JAPANESE	68 233 90
1		CONTROLLER HOUSING	68 230 05
2		CONTROLLER CHASSIS	68 230 00
3		IMPELLER	68 205 41
4		HOSE CLAMP	20 015 65
5		MOTOR ASSEMBLY	68 230 20
6		HEX NUT, 8 - 32 KEPS	99 106 32
7		VIBRATION ISOLATOR	68 230 24
8		LOCTITE #222	AR
9		MOTOR SHAFT SEAL	68 230 27
10		HEATER, 120 V	68 230 35
		HEATER, 240 V	68 230 36
		HEATER, 100 V	68 230 37
11		HEATER BAFFLE PLATE	68 208 20
12		HEATER PLATE SPACER	26 516 05
13		GASKET	26 503 00
14		STIFFENER PLATE	68 230 46
15		LOCK WASHER 7/16" ID	99 127 41
16		HEATER ASSEMBLY NUT, 6-32 HEX	99 105 70
17		POST BUMPER	68 215 12
18		COMPOUND, LOCTITE RC680	AR
19		LOCQUIC PRIMER, GR "T" #47 - 56	AR
20		DUAL THERMISTOR ASSEMBLY, BLUE	68 214 78
21		GASKET	26 501 00
22		CEMENT, 3M, EC800	AR
23		THERMOSTAT PLUG	12 512 01
24		NUT, HEX, 15/32 - 32 UNF 2B	68 215 11
25		NOT USED	
26		SHOULDER WASHER, INSULATING	99 127 69
27		AIR FLOW THERMISTOR ASSEMBLY	68 214 81
28		NUT, 3/8" X 24, HEX, BR, NI, THIN	99 111 80
29		FLAT WASHER, 3/8" ID X 0.62 OD	99 126 70
30		FIBER WASHER	17 803 40
31		HEATER CAUTION LABEL	68 208 30
32		SCREW, 10 - 32 X 1/2 TR PH SS NYLOCK	99 042 05
33		CHASSIS STERILIZING CAUTION LABEL, MOUNTED DIRECTLY UNDER ITEM 23, ENG	68 212 15

Change 4

TABLE 6.23 CONTROLLER ASSEMBLY, C500/550 QT® MODEL XL, PARTS LIST

(Sheet 2 of 3)

ITEM NO.	REFERENCE DESIG.	DESCRIPTION	PART NUMBER
34		COOLING FAN ASSEMBLY	68 230 60
35		HEX NUT, 6 - 32 KEPS	99 165 34
36		CONTROLLER LOCKING PIN	68 233 07
38		NOT USED	
39		LATCH ASSEMBLY, RIGHT	68 230 11
40		LATCH ASSEMBLY, LEFT	68 230 10
41		MANUAL REFERENCE LABEL	68 160 05
42		RIGHT SIDE CHASSIS	68 230 01
43		SCREW, 8 - 32 X 3/8" PHILLIPS HEAD	99 031 38
44		SCREW, 10 - 32 X 3/8" PHILLIPS HEAD	99 041 35
45		SCREW 6-32 X 1/4" PN PH SS, SEMS EX	99 022 83
46		HEATER BOARD ASSY (REF TO TABLE 6.10) 100/120V 220V	68 366 70 68 366 71
47		AC ENTRY BOARD, (REFER TO TABLE 6.9)	
		120 VAC	68 365 70
		240 VAC	68 365 71
		100 VAC	68 365 72
		230 VAC GERMAN	68 365 73
48		MAIN BOARD (REFER TO TABLE 6.11) 240V INT	68 372 70
		MAIN BOARD (REFER TO TABLE 6.11) 120V ENG	68 372 71
		MAIN BOARD (REFER TO TABLE 6.11) 100V JAPANESE	68 372 72
49		POWER SUPPLY	68 230 30
50		MONITOR HYBRID	68 367 70
51		CONTROL HYBRID	68 368 70
52		NUT, 3/8 - 16, HEX, ES S CA	99 111 25
53		POWER SUPPLY INSULATOR	68 230 28
54		SCREW, 6 - 32 X 1/4" SQ, CONE, WHR, SEMS	99 022 84
55		RIBBON CABLE CLAMP	17 062 11
56		CORD CLIP	17 725 44
57		NUT, 6 - 32, HEX FL KEPS	99 105 70
58		FLAT WASHER, #6 SS	99 122 03
59		PCB SPACER, 0.50" LG PLASTIC	17 062 72
60		CABLE ASSEMBLY MAIN BOARD TO HEATER BOARD	68 231 05
61		CABLE ASSEMBLY, POWER SUPPLY TO MAIN BOARD	68 231 07
62		CABLE ASSEMBLY, POWER SUPPLY TO AC ENTRY BD	68 231 08
63		CABLE ASSEMBLY, AC ENTRY BOARD TO HEATER BD	68 231 00
64		CABLE ASSEMBLY, AC ENTRY BOARD TO MAIN BOARD	68 231 03
65		SCREW, 6 - 32 1/4" SQ CON SEMS	99 022 84
66		THREADED STANDOFF	99 116 44
67		SCREW, 4 - 40 X 3/8" SEMS	99 011 13
68		NOT USED	
69		NOT USED	
70		NOT USED	

Change 6

TABLE 6.23 CONTROLLER ASSEMBLY, C500/550 QT® MODEL XL, PARTS LIST

(Sheet 3 of 3)

ITEM NO.	REFERENCE DESIG.	DESCRIPTION	PART NUMBER
71		FRONT PANEL OVERLAY C550 ENG	68 231 50
		C550 INTERNATIONAL	68 231 52
		FRONT PANEL OVERLAY C500 ENG	68 230 50
		C500 INTERNATIONAL	68 230 52
72		VACUUM FLUORESCENT DISPLAY MODULE	17 777 39
		VACUUM FLUORESCENT DISPLAY MODULE JAPANESE	17 777 40
73		DISPLAY BOARD ASSEMBLY C500 (REFER TO TABLE 6.12)	68 371 71
		DISPLAY BOARD ASSEMBLY C550 (REFER TO TABLE 6.12)	68 371 70
		DISPLAY BOARD ASSEMBLY C550 JAPANESE (REFER TO TABLE 6.12)	68 371 72
74		CABLE ASSEMBLY, MAIN BOARD TO DISPLAY BD	68 231 04
75		CABLE ASSEMBLY, VFD MODULE TO DISPLAY BD	68 231 06
76		SCREW, 6-32 1/4 SEMS	99 022 84
77		NOT USED	
78		NON-INTERCHANGEABILITY LABEL	
		C550, ENG	68 233 70
		C550, 240V, ENG	68 237 80
		C550, 100V, JPN	68 233 90
		C500, 120V, ENG	68 234 70
		C500, 240V, ENG	68 234 80

Change 5

(This page is intentionally left blank.)

Change 4

SECTION 7 DIAGRAMS

7.1 GENERAL

This section provides schematic diagrams for the Isolette® Infant Incubators, Models C500 QT® and C550 QT®.

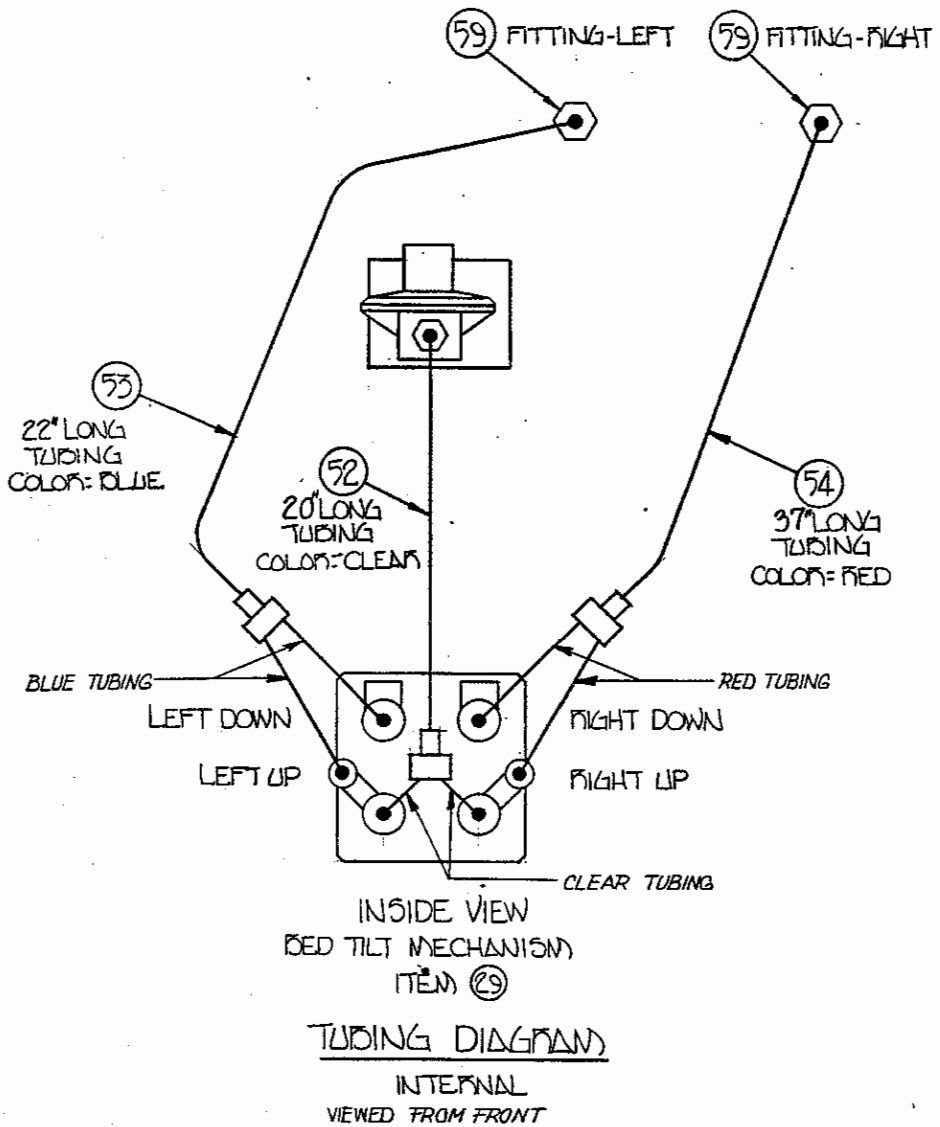

FIGURE 7.1 PNEUMATIC SCHEMATIC

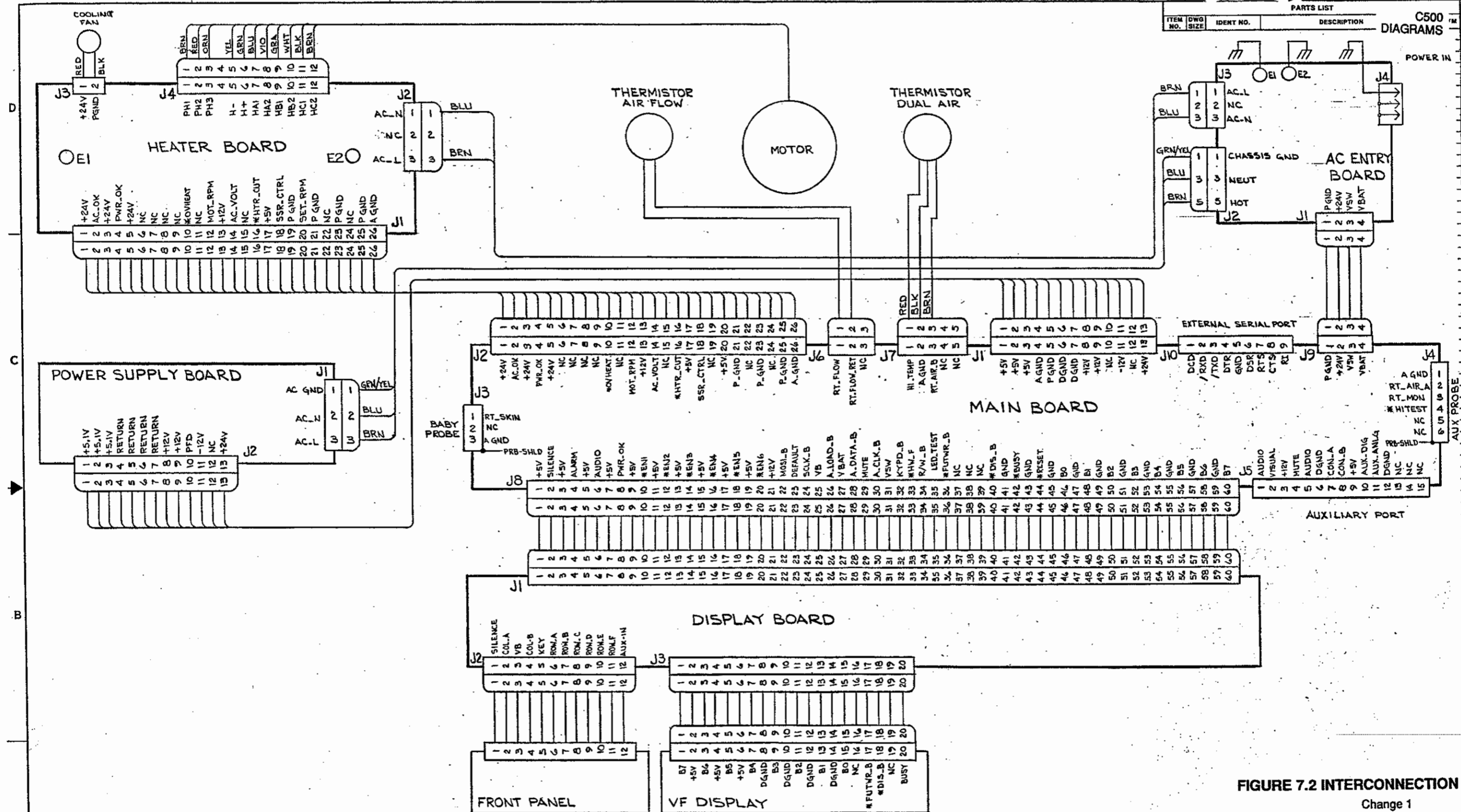

FIGURE 7.2 INTERCONNECTION DIAGRAM
Change 1

<p>THIS DOCUMENT IS PROPRIETARY INFORMATION. REPAIR AND MODIFICATIONS SHOULD BE PERFORMED ONLY BY AUTHORIZED SERVICE PERSONNEL TO MAINTAIN YOUR WARRANTY AND TO PREVENT CREATING SAFETY HAZARDS. WE CAN NOT ASSUME RESPONSIBILITY FOR ANY CONDITIONS AFFECTING THE PROPER OPERATION OF THIS EQUIPMENT WHICH MAY RESULT FROM UNAUTHORIZED REPAIR OR MODIFICATION.</p>	<p>UNLESS OTHERWISE SPECIFIED - DIMENSIONS ARE IN INCHES. TOLERANCES ON: FRACTIONS DECIMALS ANGLES ± ± ± ALL SURFACE FINISH √MAX. DO NOT SCALE DRAWING</p>	<p>SIGNATURES DATE DRAWN J. Allison 7 DEC 90 CHKD ENG A. Johnson 8 30 91 APVD</p>	<p>Air-Shields 330 Jacksonville Road, Harboro, PA 19040</p>
	<p>MATERIAL</p>	<p>FINISH</p>	<p>INTERCONNECTION DIAGRAM C500/C550</p>
	<p>NEXT ASSY:</p>	<p>SCALE 1/8"</p>	<p>SIZE D 7-3 SHEET 1 of 1</p>
	<p>DO NOT SCALE DRAWING</p>	<p>FINISH</p>	

PARTS LIST					REVISIONS	
ITEM NO.	DWG. SIZE	IDENT. NO.	DESCRIPTION	QTY.	U/M	F. PRELIM DRN 910-30

C500
DIAGRAMS

JA	3 MAY 91	RJK	6 May 91
G. DRN 910-70 CB1 & 2 WERE GA ON ASSY 71			
JA	16 SEPT 91	RJK	16 Sept 91
1. DEN 910-85, ISSUE E1 & E2 WENT TO SAME GND SYM.			
JA	11 DEC 91	RJK	17 Dec 91
2. ECN 10526: AT "CB1, 2" ADD "72" ASSY.			
88	30 AUG 93	RJK	31 Aug 93

LAST CMPNT USED	
USED	OMITTED
CB2	
E2	
J4	
R3	
S1	

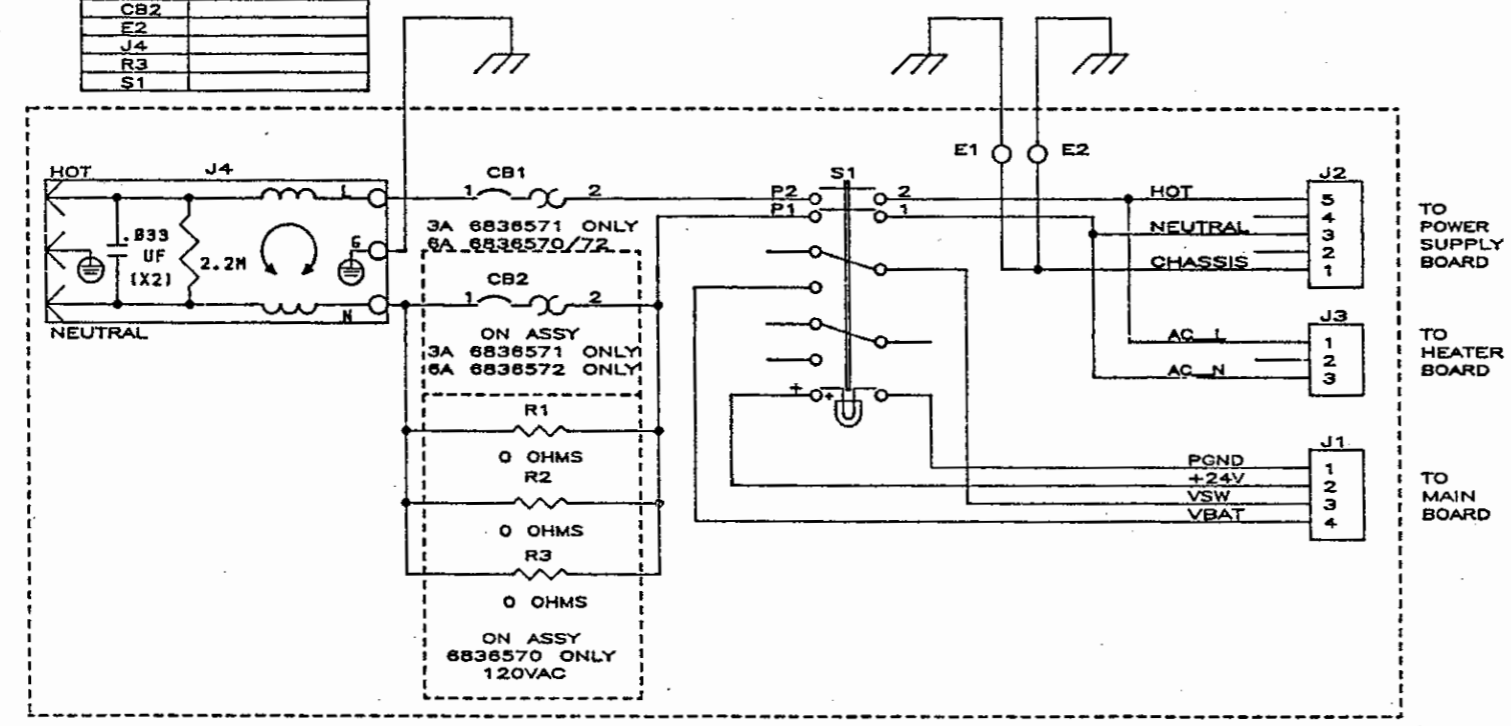

AN ELECTRONIC COPY OF THIS DOCUMENT IS STORED IN ITS ENTIRETY ON 1-3 1/2 DISKETTE IN THE ENGINEERING PRINT ROOM UNDER THE TITLE "C500/550 CONTROLLER AC ENTRY SCHEMATIC, PN 68 365 15". THE DATA MAY BE READ ON ANY DOS BASED PC USING ORCAD, VERSION 3.22 AS FOLLOWS:

\\REV1\6836515.SCH REVISION 2

FIGURE 7.3 SCHEMATIC DIAGRAM, AC ENTRY BOARD

Change 3

<p>This document is proprietary information. Repairs and modifications should be performed only by authorized service personnel to maintain your warranty and to avoid creating safety hazards. We can not assume responsibility for any conditions affecting the proper operation of this equipment which may result from unauthorized repair or modification.</p>	<p>UNLESS OTHERWISE SPECIFIED, DIMENSIONS ARE IN INCHES: TOLERANCES ON: FRACTIONS DECIMALS ANGLES ± — .XX ± — ± — .XXX ± — √ MAX.</p>	SIGNATURES		DATE	<p>Air-Shields 330 Jacksonville Road, Hatboro, PA 19040</p> <p>SCHEMATIC, AC ENTRY</p>
		DRAWN	<i>Alison</i>	25 APR 91	
NEXT ASSY:	MATERIAL	CHKD			<p>SCALE #</p>
		ENG	<i>R. Kluwa</i>	6 May 91	
		APVD			<p>SHEET 1 of 1</p>
		FINISH			

LAST CMPNT USED	
USED	OMITTED
CB2	
E2	
J4	
L2	
R3	
S1	

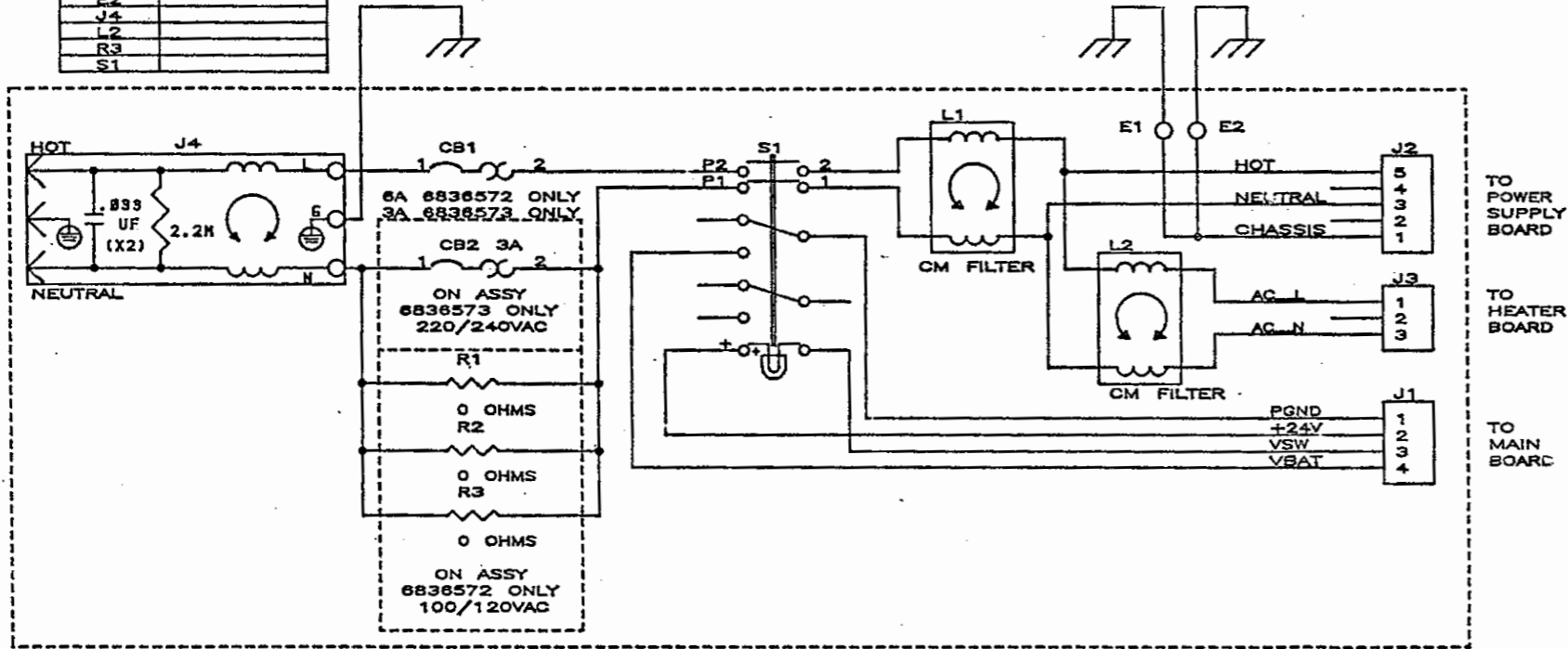

AN ELECTRONIC COPY OF THIS DOCUMENT IS STORED IN ITS ENTIRETY ON 1-3 1/2 DISKETTE IN THE ENGINEERING PRINT ROOM UNDER THE TITLE "C500/550 CONTROLLER AC ENTRY SCHEMATIC, PN 68 365 16". THE DATA MAY BE READ ON ANY DOS BASED PC USING ORCAD, VERSION 3.22 AS FOLLOWS:

\\REV1\6836516.SCH

REVISION 1

FIGURE 7.3A SCHEMATIC DIAGRAM,
AC ENTRY BOARD, 230V, GERMAN

Change 1

<p>This document is proprietary information. Repairs and modifications should be performed only by authorized service personnel to maintain your warranty and to avoid creating safety hazards. We can not assume responsibility for any conditions affecting the proper operation of this equipment which may result from unauthorized repair or modification.</p>	<p>UNLESS OTHERWISE SPECIFIED- DIMENSIONS ARE IN INCHES: TOLERANCES ON:</p> <table border="0"> <tr> <td>FRACTIONS</td> <td>DECIMALS</td> <td>ANGLES</td> </tr> <tr> <td>±</td> <td>.XX ±</td> <td>±</td> </tr> <tr> <td></td> <td>.XXX ±</td> <td>✓ MAX.</td> </tr> </table>	FRACTIONS	DECIMALS	ANGLES	±	.XX ±	±		.XXX ±	✓ MAX.	<p>SIGNATURES</p> <p>DATE</p>	<p>Air-Shields 330 Jacksonville Road, Hatboro, PA 19040</p> <p>SCHEMATIC AC ENTRY, (EMI)</p>
	FRACTIONS	DECIMALS	ANGLES									
	±	.XX ±	±									
		.XXX ±	✓ MAX.									
<p>NEXT ASSY:</p>	<p>DO NOT SCALE DRAWING</p>	<p>DRAWN <i>alison</i> 14 Oct 92</p> <p>CHKD</p> <p>ENG <i>Ron Klumpp</i> 27 Oct 92</p> <p>APVD</p>										
<p>MATERIAL</p>	<p>FINISH</p>	<p>SIZE</p> <p>B</p>										
<p>SCALE <i>7/8</i></p>	<p>SHEET</p> <p>1 OF 1</p>	<p>7-4A</p>										

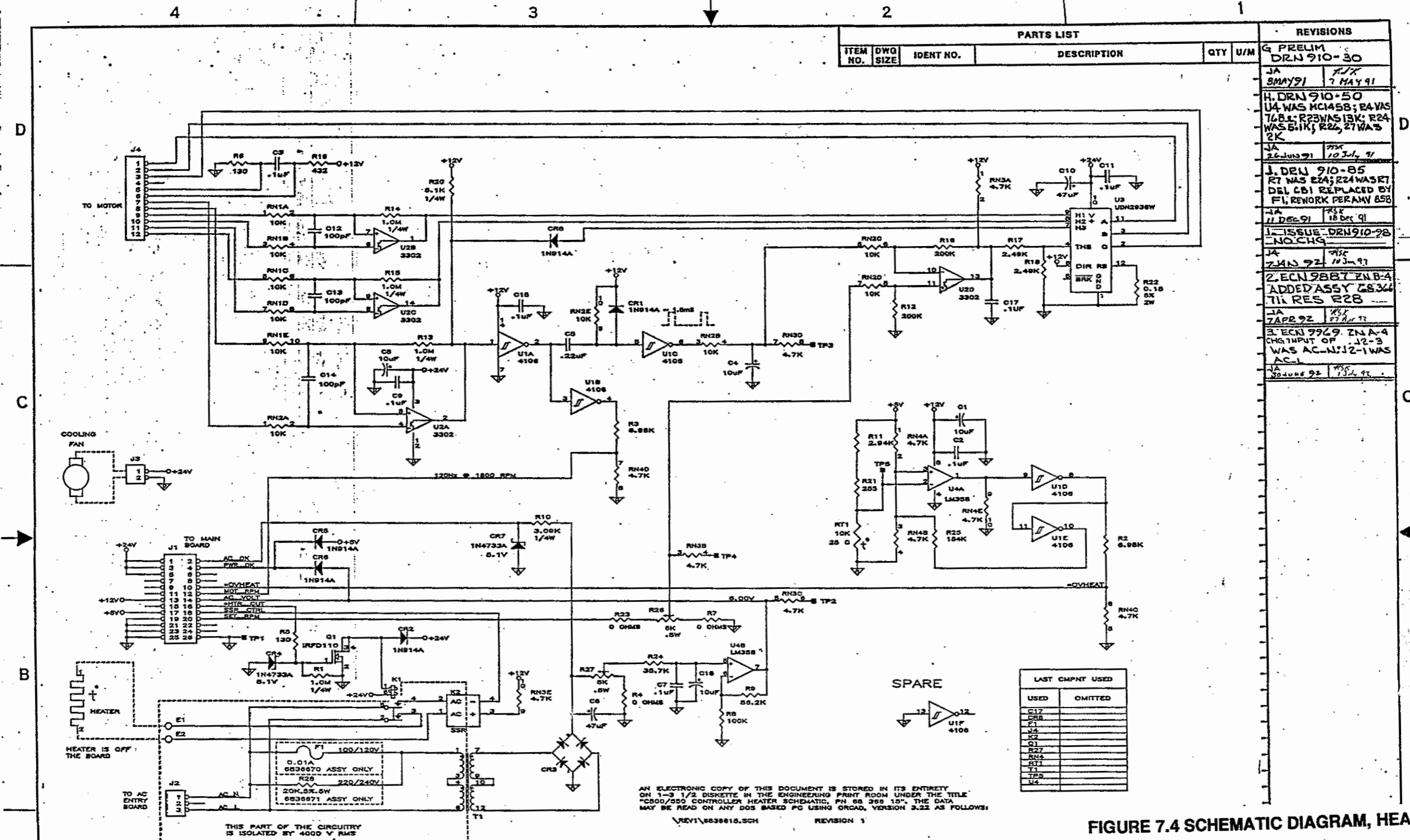

ITEM NO.	DWG SIZE	IDENT NO.	DESCRIPTION	QTY	U/M
----------	----------	-----------	-------------	-----	-----

REVISIONS	
G. PRELIM DRN 910-30	
JA 5MAY91	7 MAY 91
H. DRN 910-50	
U4 WAS MC1458; R4 WAS 768K; R23 WAS 13K; R24 WAS 5.1K; R26, 27 WAS 2K	
JA 26 JUN 91	10 JUL 91
I. DRN 910-85	
R7 WAS E2A; R24 WAS R7 DEL. C61 REPLACED BY F1. Rework PERAWY 858	
JA 11 DEC 91	18 DEC 91
1. ISSUE DRN 910-98	
NO CHG	
JA 7 JUN 92	10 JUN 92
2. ECN 9887 ZNA-B-4	
ADDED ASSY 2834	
TH RES R28	
JA 7 APR 92	27 APR 92
3. ECN 9929 ZNA-A-4	
CHG INPUT OF J2-3	
WAS AC-N; J2-1 WAS AC-1	
JA 30 JUNE 92	13 JUL 92

LAST CMPNT USED	
USED	OMITTED
C17	
C28	
E1	
J4	
K2	
Q1	
R27	
RN4	
RT1	
TP2	
U4	

AN ELECTRONIC COPY OF THIS DOCUMENT IS STORED IN ITS ENTIRETY ON 1-3 1/2 DISKETTE IN THE ENGINEERING PRINT ROOM UNDER THE TITLE "C500/550 CONTROLLER HEATER SCHEMATIC, PN 68 366 15". THE DATA MAY BE READ ON ANY DOS BASED PC USING ORCAD, VERSION 3.22 AS FOLLOWS:
 \REV1\6836615.SCH REVISION 1

FIGURE 7.4 SCHEMATIC DIAGRAM, HEATER BOARD

Change 1

- NOTES:
 UNLESS OTHERWISE SPECIFIED:
1. ALL RESISTORS ARE IN OHMS, 1%, 1/8W.
 2. ALL RESISTOR NETWORKS ARE IN OHMS
 3. ALL CAPACITORS ARE IN MICROFARADS.

THIS DOCUMENT IS PROPRIETARY INFORMATION. REPAIRS AND MODIFICATIONS SHOULD BE PERFORMED ONLY BY AUTHORIZED SERVICE PERSONNEL TO MAINTAIN YOUR WARRANTY AND TO AVOID CREATING SAFETY HAZARDS. WE CAN NOT ASSUME RESPONSIBILITY FOR ANY CONDITIONS AFFECTING THE PROPER OPERATION OF THIS EQUIPMENT WHICH MAY RESULT FROM UNAUTHORIZED REPAIR OR MODIFICATION.	UNLESS OTHERWISE SPECIFIED - DIMENSIONS ARE IN INCHES. TOLERANCES ON: FRACTIONS DECIMALS ANGLES ± — .XX ± — ± — .XXX ± — √ MAX. ALL SURFACE FINISH	SIGNATURES	DATE	Air-Shields 330 Jacksonville Road, Hatboro, PA 19040
		DRAWN <i>albert</i>	26 APR 91	
NEXT ASSY:	MATERIAL	CHKD		SCHEMATIC, HEATER BOARD
		ENG <i>R. J. ...</i>	7 MAY 91	
		APVD <i>...</i>	23 JUL 91	SIZE C
		FINISH		7-5
				SCALE <i>H</i>
				SHEET 1 of 1

A

DIST TO

E. PRELIM DEN 910-30
 J.A. MAY 91
 F. DRN 910-405 CHG 1 NO. 01111-5 TO AGENT WITH AETWORK
 J.A. MAY 91
 G. DRN 910-50-AD J1, NOTES 5 & U21-210 U21-22, DE L101-2 1 U22-34, U21-2 1/2 5K-CTRL; RENUM BERER KE TO AGE WITH AETWORK; C25 WAS 3
 J.A. MAY 91
 H. DRN 910-70 R11 WAS 4.32K
 J.A. MAY 91
 I. DRN 910-80 SPARE DEL EN46 RWH 418K ADD R15H R15A EN46 R15 WAS 837A, KEW0 PER AMV 852
 J.A. MAY 91
 J. ISSUE DRN 910-1 ADD TP1, C29 WEN TO P100D
 J.A. MAY 91
 K. ECN 10155 550C 55A 2
 J.A. MAY 91
 L. ECN 10611 (A, B, C, D) ADDED NOTE (C) ADDED "SEE NOTE 4" CALLOUT.
 J.A. NOV 93

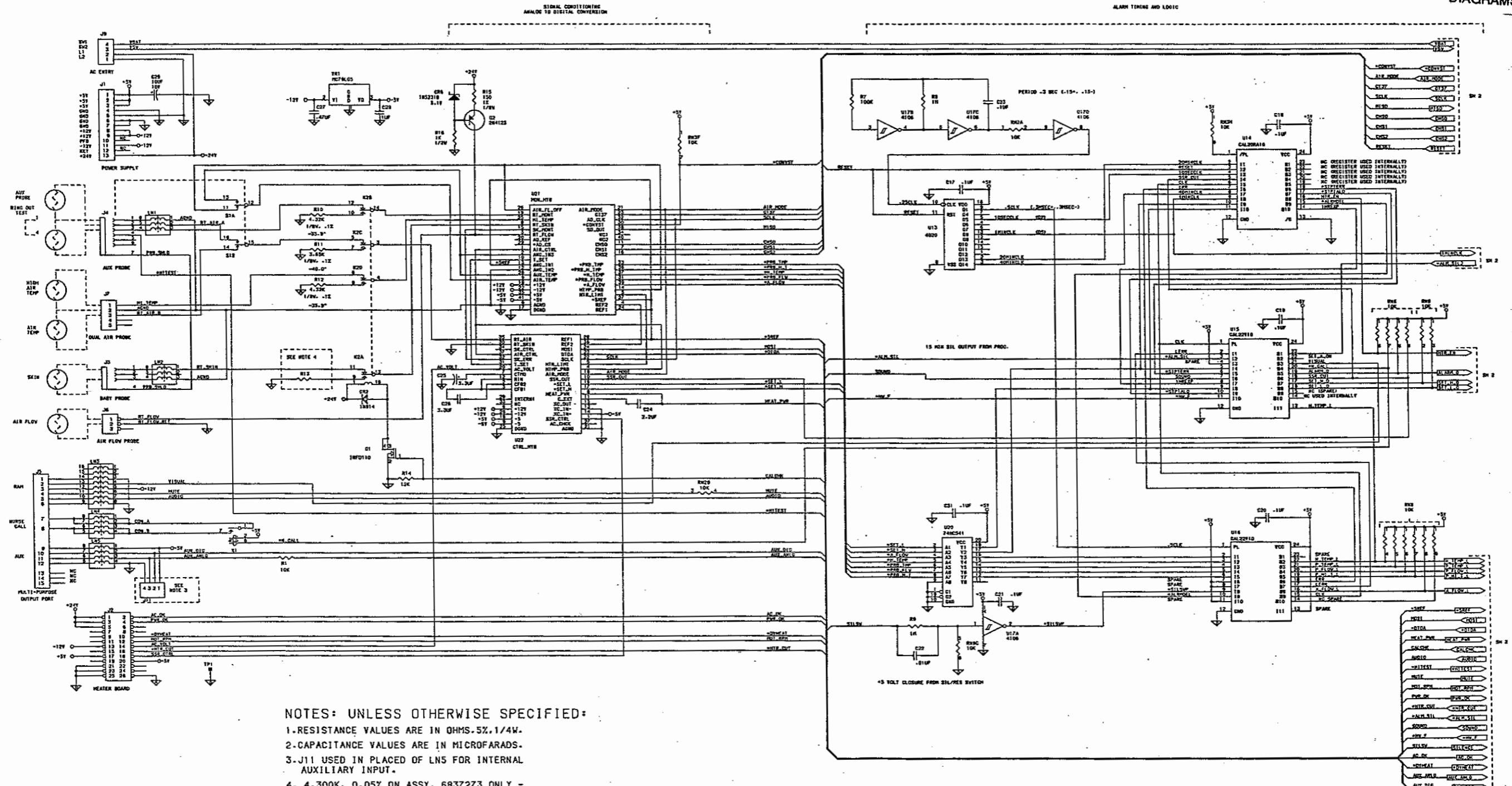

- NOTES: UNLESS OTHERWISE SPECIFIED:
1. RESISTANCE VALUES ARE IN OHMS, 5%, 1/4W.
 2. CAPACITANCE VALUES ARE IN MICROFARADS.
 3. J11 USED IN PLACED OF LNS FOR INTERNAL AUXILIARY INPUT.
 4. 4.300K, 0.05% ON ASSY. 6837273 ONLY - 4.320K, 0.1% FOR ALL OTHER ASSYS.

LAST OPTI USED	
USED	OMITTED
C06	
C07	C1.2
C08	
C09	
C10	
C11	
C12	
C13	
C14	
C15	
C16	
C17	
C18	
C19	
C20	
C21	
C22	
C23	
C24	
C25	
C26	
C27	
C28	
C29	
C30	
C31	
C32	
C33	
C34	
C35	
C36	
C37	
C38	
C39	
C40	
C41	
C42	
C43	
C44	
C45	
C46	
C47	
C48	
C49	
C50	
C51	
C52	
C53	
C54	
C55	
C56	
C57	
C58	
C59	
C60	
C61	
C62	
C63	
C64	
C65	
C66	
C67	
C68	
C69	
C70	
C71	
C72	
C73	
C74	
C75	
C76	
C77	
C78	
C79	
C80	
C81	
C82	
C83	
C84	
C85	
C86	
C87	
C88	
C89	
C90	
C91	
C92	
C93	
C94	
C95	
C96	
C97	
C98	
C99	
C100	

AN ELECTRONIC COPY OF THIS DOCUMENT IS STORED IN ITS ENTIRETY ON 1-3 1/2 DISKETTES IN THE ENGINEERING PRINT ROOM UNDER THE TITLE "C500/500 CONTROLLER MAIN SCHEMATIC, PP 68 372 12". THE DATA MAY BE READ ON ANY DOS BASED PC USING DRCAD, VERSION 3.22 AS FOLLOWS:
 \VEN1\6837215.SCH REVISION 1
 \VEN1\6837215.SCH REVISION 2
 \VEN1\6837215.SCH REVISION 3

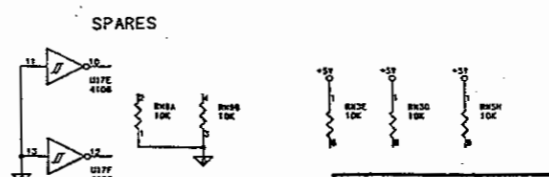

FIGURE 7.5 SCHEMATIC DIAGRAM, MAIN BOARD (SHEET 1 OF 2)

Change 3

<p>THIS DOCUMENT IS PROPRIETARY INFORMATION. REPAIRS AND MODIFICATIONS SHOULD BE PERFORMED ONLY BY AUTHORIZED SERVICE PERSONNEL TO MAINTAIN YOUR WARRANTY AND TO AVOID CREATING SAFETY HAZARDS. WE CAN NOT ASSUME RESPONSIBILITY FOR ANY CONDITIONS AFFECTING THE PROPER OPERATION OF THIS EQUIPMENT WHICH MAY RESULT FROM UNAUTHORIZED REPAIR OR MODIFICATIONS.</p>	<p>UNLESS OTHERWISE SPECIFIED - DIMENSIONS ARE IN INCHES. TOLERANCES ON: FRACTIONS DECIMALS ANGLES ± .005 ± .001 ± 15° ALL SURFACE FINISH - √ MAX. DO NOT SCALE DRAWING</p>	<p>SIGNATURES DATE DRAWN <i>Allen</i> 5 APR 91 ENG <i>R. Klein</i> 10/87 APVD <i>[Signature]</i> 14 JUN 91</p>	<p>Air-Shields 330 Jacksonville Road, Harboro, PA 19040</p>
	<p>MATERIAL H</p>	<p>FINISH H</p>	<p>SIZE D 7-6 SCALE 1/8" = 1"</p>

PARTS LIST				REVISIONS
ITEM NO.	DWG SIZE	IDENT NO.	DESCRIPTION	QTY U/M
				E. PRELIM DEN 910-1
				F. DEN 910-40; CHG W/04N LML TO AG FREE WITH A RT 10 D.E.C.
				G. DEN 910-52
				H. DEN 910-70; C NOTE AT U9 PERMIT USE ON THIS ASSY TO OPTIONAL!
				I. DEN 910-85
				J. DEN 910-85
				K. DEN 910-85
				L. DEN 910-85
				M. DEN 910-85
				N. DEN 910-85
				O. DEN 910-85
				P. DEN 910-85
				Q. DEN 910-85
				R. DEN 910-85
				S. DEN 910-85
				T. DEN 910-85
				U. DEN 910-85
				V. DEN 910-85
				W. DEN 910-85
				X. DEN 910-85
				Y. DEN 910-85
				Z. DEN 910-85

**C500
DIAGRAMS**

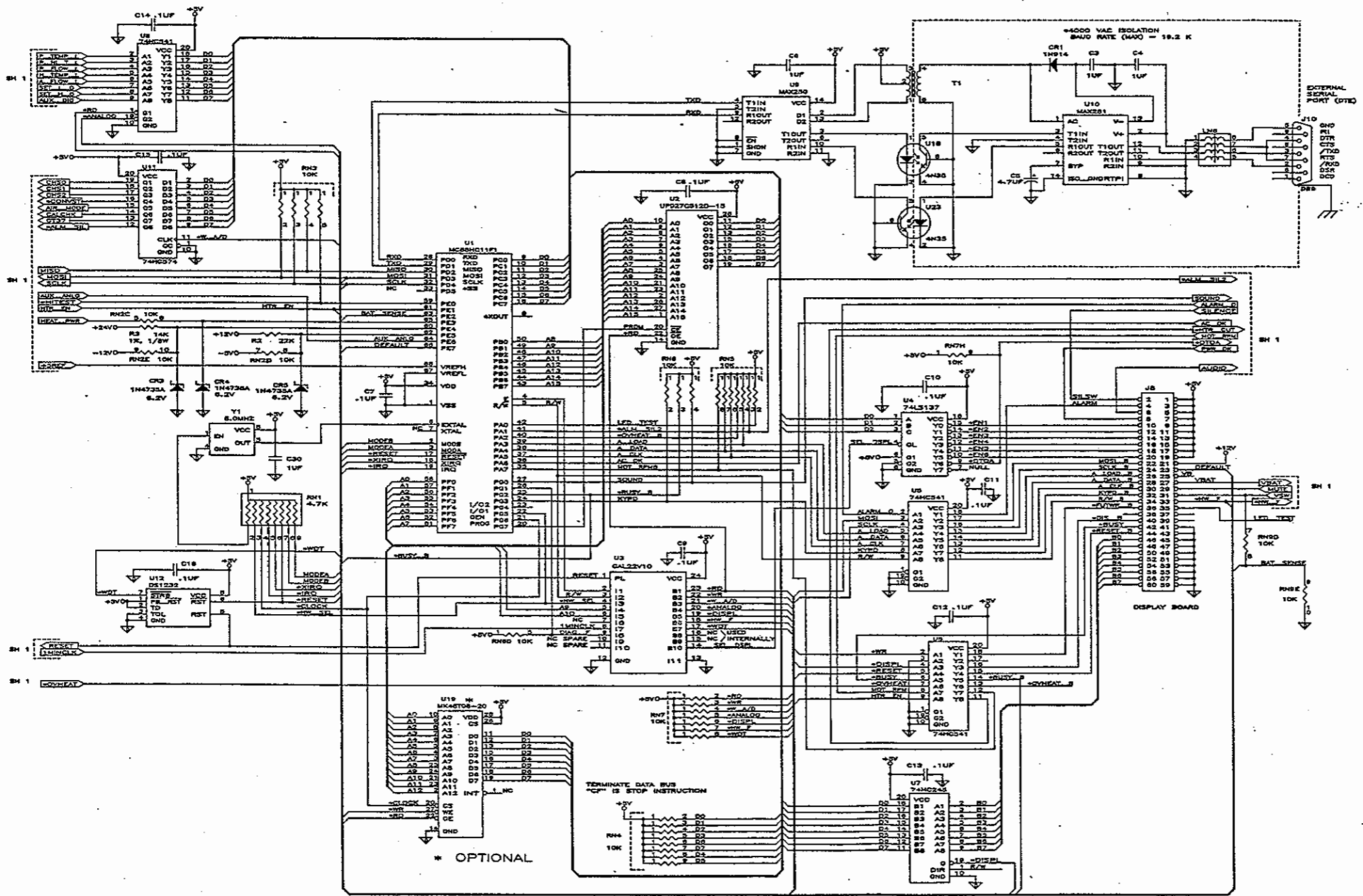

FIGURE 7.5 SCHEMATIC DIAGRAM, MAIN BOARD (SHEET 2 OF 2)

Change 3

THIS DOCUMENT IS PROPRIETARY INFORMATION, DETAILS AND SPECIFICATIONS SHOULD BE PERFORMED ONLY BY AUTHORIZED SERVICE PERSONNEL TO MAINTAIN YOUR WARRANTY AND TO AVOID CREATING SAFETY HAZARDS. WE CAN NOT ASSUME RESPONSIBILITY FOR ANY CONDITIONS AFFECTING THE PROPER OPERATION OF THIS EQUIPMENT WHICH MAY RESULT FROM UNAUTHORIZED SERVICE OR MODIFICATION.	UNLESS OTHERWISE SPECIFIED - DIMENSIONS ARE IN INCHES. TOLERANCES ON:		SIGNATURES DATE DRAWN: <i>[Signature]</i> 20 APR 91 CHECKED: ENG: <i>[Signature]</i> 10 MAY 91 APVD: <i>[Signature]</i> 14 JUN 91 FINISH:	Air-Shields 330 Jacksonville Road, Hatboro, PA 19040 SCHEMATIC MAIN BOARD	
	FRACTIONS	DECIMALS			ANGLES
	±	.XX ±			±
	±	.XXX ±			±
ALL SURFACE FINISH	DO NOT SCALE DRAWING		SCALE: <i>[Handwritten]</i>		
DO NOT SCALE DRAWING	MATERIAL		SIZE: D 7-7		
FINISH	NEXT ASSY:		SHEET 2		

LAST COMPONENT USED	USED	OMITTED
BT1		
CR14		
C32		
DS28		
J3		
LS1		
R28		
R29		
TP27		
U19		

AN ELECTRONIC COPY OF THIS DOCUMENT IS STORED IN ITS ENTIRETY ON 1-3 1/2 DISKETTE IN THE ENGINEERING PRINT ROOM UNDER THE TITLE "C500/550 CONTROLLER DISPLAY SCHEMATIC PN 89 371 10". THE DATA MAY BE READ ON ANY DOS BASED PC USING ORCAD, VERSION 3.22 AS FOLLOWS:
 REV1/8837110.SCH REVISION 1

ITEM NO.	DWG NO.	IDENT NO.	DESCRIPTION
1	C500		DIAGRAMS

REVISIONS
 H. DEN 910-10-1
 PRELIM

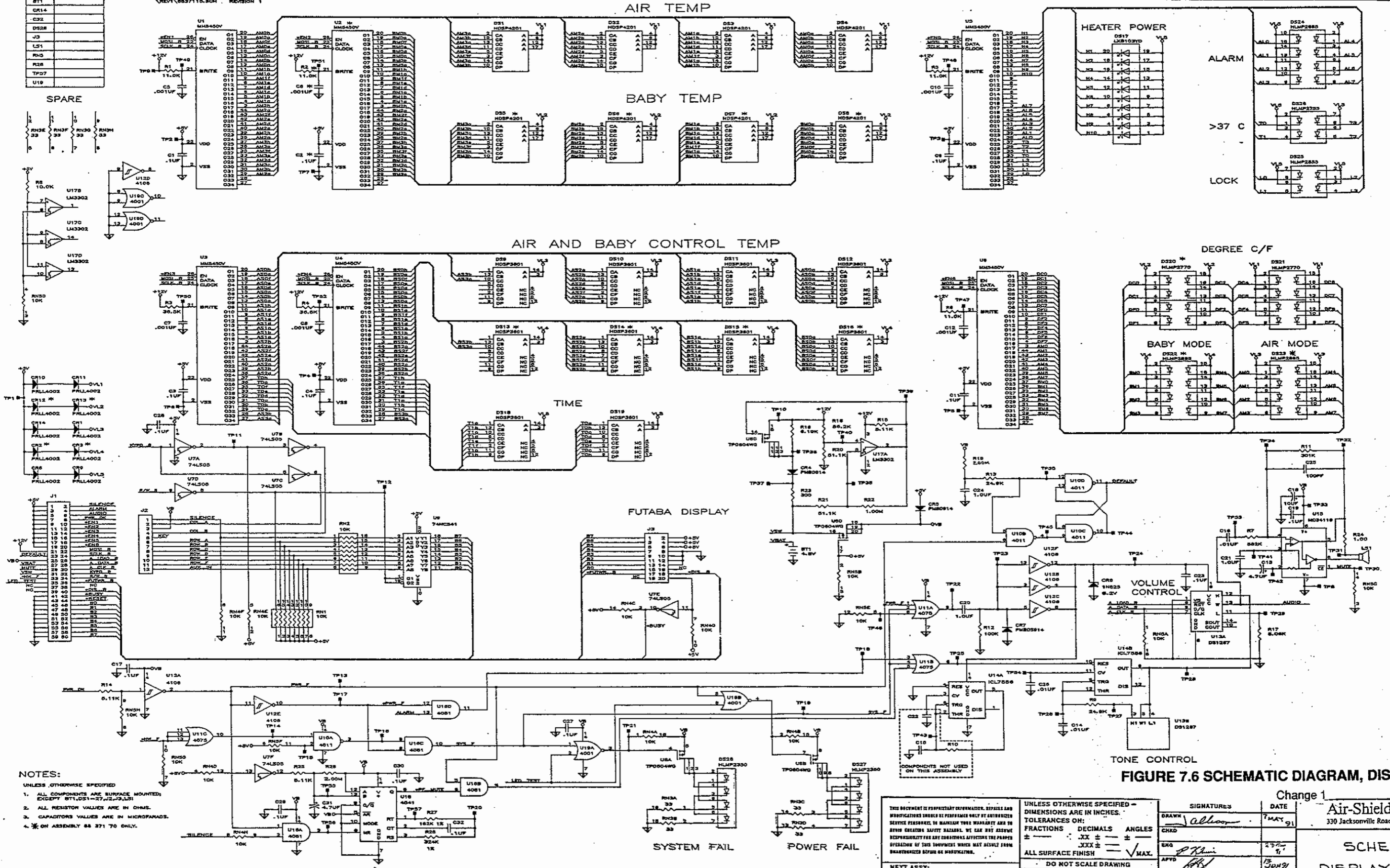

- NOTES:
 UNLESS OTHERWISE SPECIFIED
 1. ALL COMPONENTS ARE SURFACE MOUNTED EXCEPT BT1,DS1-27,23,LS1
 2. ALL RESISTOR VALUES ARE IN OHMS.
 3. CAPACITORS VALUES ARE IN MICROFARADS.
 4. ON ASSEMBLY 88 371 70 ONLY.

FIGURE 7.6 SCHEMATIC DIAGRAM, DISPLAY BOARD

THIS DOCUMENT IS PROPRIETARY INFORMATION. REPAIRS AND MODIFICATIONS SHOULD BE PERFORMED ONLY BY AUTHORIZED SERVICE PERSONNEL TO MAINTAIN YOUR WARRANTY AND TO AVOID CREATING SAFETY HAZARDS. WE CAN NOT ASSUME RESPONSIBILITY FOR ANY CONDITIONS AFFECTING THE PROPER OPERATION OF THIS EQUIPMENT WHICH MAY RESULT FROM UNAUTHORIZED REPAIR OR MODIFICATION.

SIGNATURES		DATE
DRAWN	<i>Jalton</i>	1 MAY 91
CHKD		
ENG	<i>P. Kline</i>	23 JUN 91
APPV	<i>H. J.</i>	13 JUN 91
FINISH		

Change 1
 Air-Shields
 330 Jacksonville Road, Hatboro, PA 19040
 SCHEMATIC,
 DISPLAY BOARD

SIZE	SHEET
D	7-8
SCALE	1/1

PARTS LIST					REVISIONS	
ITEM NO.	DWG NO.	IDENT NO.	DESCRIPTION	QTY	U/M	E. PRELIM
						DRN 910-30
						7 MAY 91 10 44 AM 91
						DRN 910-56: P11
						J2 WAS SK_CTL
						1 ISSUE DRN 910
						NO CHG
						2 JAN 92 7 58 PM 92

C500 DIAGRAMS

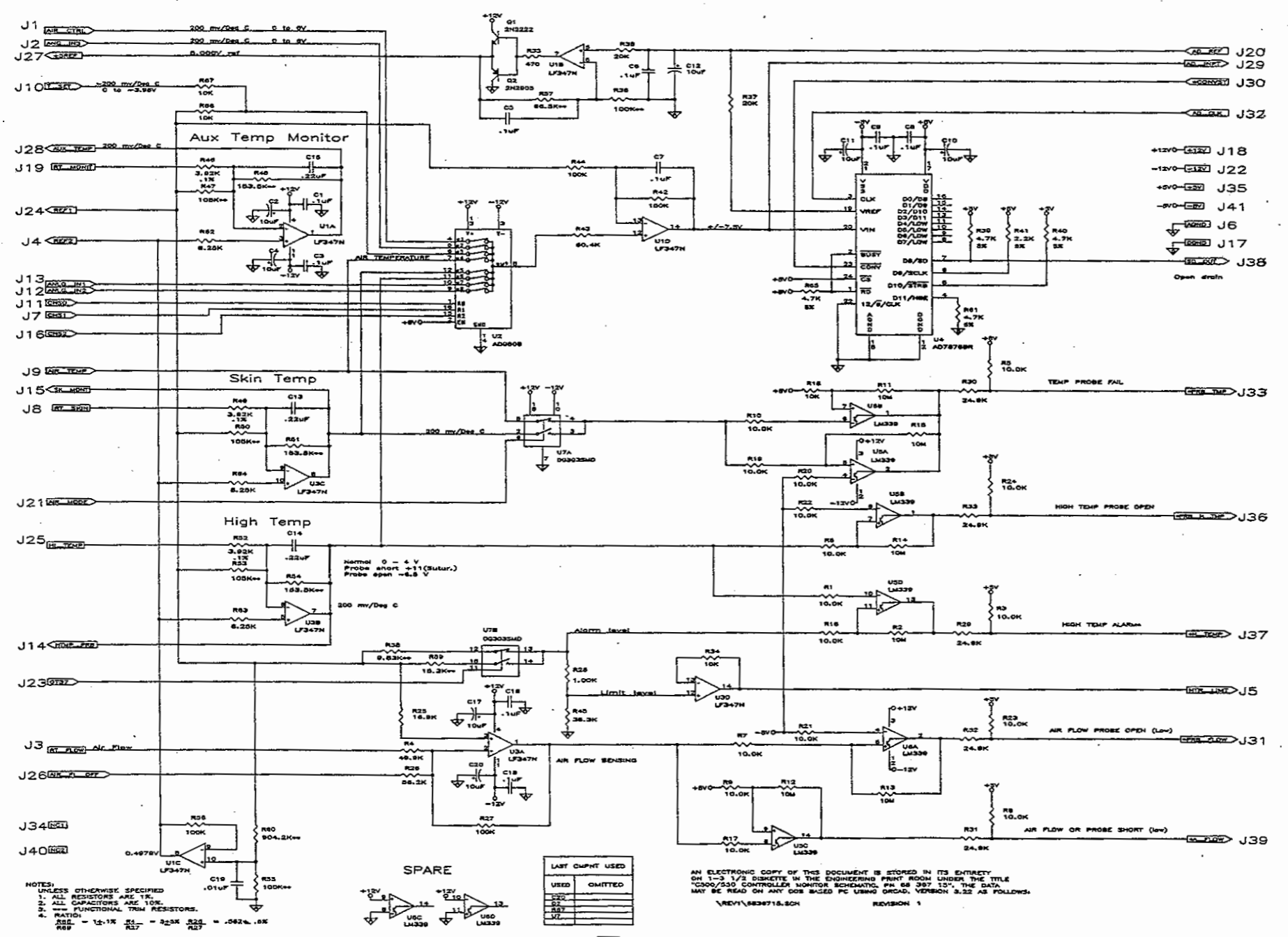

- NOTES:**
UNLESS OTHERWISE SPECIFIED:
1. ALL RESISTORS ARE 1%.
2. ALL CAPACITORS ARE 10%.
3. = FUNCTIONAL TRIM RESISTORS.
4. RATIO:
R25 = 1:1% R5 = .042% R27 = .042% .0K
R26

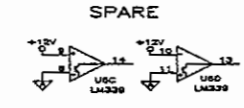

USED	OMITTED

AN ELECTRONIC COPY OF THIS DOCUMENT IS STORED IN ITS ENTIRETY ON 1-3 1/2 DISKETTE IN THE ENGINEERING PRINT ROOM UNDER THE TITLE "C500/530 CONTROLLER MONITOR SCHEMATIC, PN 58 387 10". THE DATA MAY BE READ ON ANY DOS BASED PC USING DDCAD, VERSION 3.32 AS FOLLOWS:
\\REVL1839715.BOH REVISION 1

FIGURE 7.7 SCHEMATIC DIAGRAM, MONITOR HYBRID

<p>THIS DOCUMENT IS PROPRIETARY INFORMATION, REPAIRS AND MODIFICATIONS SHOULD BE PERFORMED ONLY BY AUTHORIZED SERVICE PERSONNEL TO MAINTAIN YOUR WARRANTY AND TO AVOID CREATING SAFETY HAZARDS. WE CAN NOT ASSUME RESPONSIBILITY FOR ANY CONDITIONS AFFECTING THE PROPER OPERATION OF THIS EQUIPMENT WHICH MAY RESULT FROM UNAUTHORIZED REPAIR OR MODIFICATION.</p>	<p>UNLESS OTHERWISE SPECIFIED - DIMENSIONS ARE IN INCHES. TOLERANCES ON: FRACTIONS DECIMALS ANGLES ± .XX ± . — ± — ± .XXX ± — — — ALL SURFACE FINISH — — √ MAX.</p>			<p>SIGNATURES</p> <p>DRAWN <i>Alleson</i> 10/27/91</p> <p>CHKD <i>H. Wilson</i> 10/27/91</p> <p>ENG <i>H. Wilson</i> 10/27/91</p> <p>APP'D</p>	<p>DATE</p> <p>10/27/91</p>						
	<p>Air-Shields 330 Jacksonville Road, Harboro, PA 19040</p>										
	<p>SCHEMATIC, MONITOR HYBRID</p>										
	<table border="1" style="width: 100%; border-collapse: collapse;"> <tr> <td style="width: 20%;">SCALE <i>1/4"</i></td> <td style="width: 20%;"></td> <td style="width: 20%;">SIZE D</td> <td style="width: 20%;">7-9</td> </tr> <tr> <td colspan="2"></td> <td style="width: 20%;">FINISH</td> <td style="width: 20%;">SHEET <i>4</i> / 10</td> </tr> </table>				SCALE <i>1/4"</i>		SIZE D	7-9			FINISH
SCALE <i>1/4"</i>		SIZE D	7-9								
		FINISH	SHEET <i>4</i> / 10								

PARTS LIST				REVISIONS	
ITEM NO.	DWG SIZE	IDENT NO.	DESCRIPTION	QTY	U/M
				E. PRELIM DRN 910-30	
				JA 2 MAY 91	
				1. ISSUE DRN 910-98	
				E50 WAS 10-OK	
				JA	
				E JAN 92 10 11	

C500
DIAGRAMS

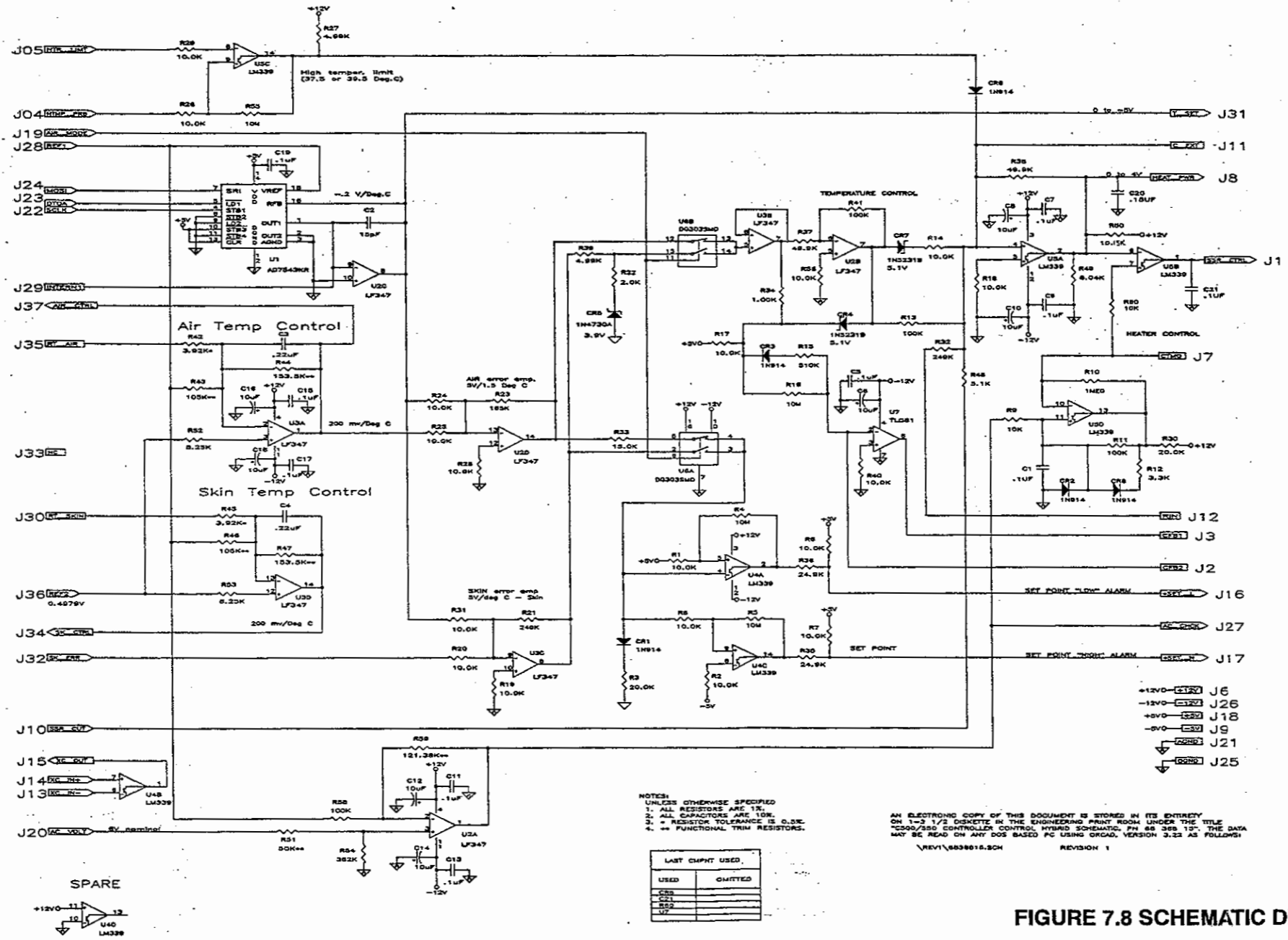

- NOTES:
 1. UNLESS OTHERWISE SPECIFIED
 1. ALL RESISTORS ARE 1%.
 2. ALL CAPACITORS ARE 10%.
 3. * RESISTOR TOLERANCE IS 0.5%.
 4. ** FUNCTIONAL TRIM RESISTORS.

AN ELECTRONIC COPY OF THIS DOCUMENT IS STORED IN ITS ENTIRETY ON 1-3 1/2 DISKETTE IN THE ENGINEERING PRINT ROOM UNDER THE TITLE "C500/350 CONTROLLER CONTROL HYBRID SCHEMATIC, PH 68 369 15". THE DATA MAY BE READ ON ANY DOS BASED PC USING OKAD, VERSION 3.22 AS FOLLOWS:
 \REV1\6038015.SCH REVISION 1

LAST CMPNT USED	
USED	OMITTED

FIGURE 7.8 SCHEMATIC DIAGRAM, CONTROL HYBRID

THIS DOCUMENT IS PROPRIETARY INFORMATION. REPAIRS AND MODIFICATIONS SHOULD BE PERFORMED ONLY BY AUTHORIZED SERVICE PERSONNEL TO MAINTAIN YOUR WARRANTY AND TO AVOID CREATING SAFETY HAZARDS. WE CAN NOT ASSUME RESPONSIBILITY FOR ANY CONDITIONS ARISING FROM THE OPERATION OF THIS EQUIPMENT WHICH MAY RESULT FROM UNAUTHORIZED REPAIR OR MODIFICATION.	UNLESS OTHERWISE SPECIFIED - DIMENSIONS ARE IN INCHES. TOLERANCES ON: FRACTIONS DECIMALS ANGLES ± .XX ± ± ALL SURFACE FINISH - √MAX.	SIGNATURES DRAWN: <i>J. Allison</i> CHECKED: <i>R. P. Davis</i> ENG: <i>R. P. Davis</i> APVD:	DATE 25 APR 91 10 MAY 91	Air-Shields 330 Jacksonville Road, Harbor, PA 19040
	DO NOT SCALE DRAWING	MATERIAL	FINISH	SIZE D 7-10
	NEXT ASSY:	SCALE: <i>1/8"</i>	SHEET: <i>1 of 1</i>	SCALE: <i>1/8"</i>
	NEXT ASSY:	SCALE: <i>1/8"</i>	SHEET: <i>1 of 1</i>	SCALE: <i>1/8"</i>

LIMITED WARRANTY

The product being described in this manual is warranted against defects in materials or workmanship for one year from the date of shipment from Hill-Rom Air-Shields, Inc., Hatboro, with the following exceptions:

All consumable and disposable products are guaranteed to be free from defects upon shipment only.

Calibrations are considered normal maintenance and are not included in the 1 year warranty.*

During the warranty period any defective parts other than those listed above will be replaced at no charge to the customer. There will be no labor charge for replacing the parts within the continental U.S.

This warranty is rendered void and Hill-Rom Air-Shields, Inc. cannot be held liable for conditions resultant therefrom if:

1. Damage to the unit is incurred as a result of mishandling.
2. The customer fails to maintain the unit in a proper manner.
3. The customer uses any parts, accessories, or fittings not specified or sold by Hill-Rom Air-Shields, Inc.
4. Sale or service is performed by a non-certified service/dealer agency.

THE FOREGOING WARRANTIES ARE EXCLUSIVE AND IN LIEU OF ALL OTHER EXPRESS WARRANTIES AND IMPLIED WARRANTIES, INCLUDING BUT NOT LIMITED TO, THE IMPLIED WARRANTIES OF MERCHANTABILITY AND FITNESS OF PURPOSE. HILL-ROM AIR-SHIELDS' OBLIGATION UNDER THESE WARRANTIES SHALL NOT INCLUDE ANY LIABILITY FOR LOSS OF PROFITS, DIRECT, INDIRECT OR CONSEQUENTIAL DAMAGES OR DELAYS. Some states, provinces, or countries do not allow the exclusion or limitation of incidental or consequential damages, so the above exclusion or limitation may not apply. Any improper or negligent use, any alterations or repairs not in accordance with Hill-Rom Air-Shields' manuals or performed by others in such manner as in Hill-Rom Air-Shields' sole judgement affects the product materially and adversely, shall void these warranties. These warranties do not cover failures due to misuse, abuse, neglect, or lack of routine maintenance. No employee or representative of Hill-Rom Air-Shields is authorized to change these warranties in any way or grant any other warranty unless in writing and signed by a Hill-Rom officer. These warranties provide specific legal rights; but, there may be other available rights; which vary from state to state, province to province, or country to country.

*The Accreditation Manual for Hospitals requires each piece of equipment to be tested prior to initial use and at least annually thereafter. To comply with this standard, we recommend that you participate in our Preventive Maintenance Program during the warranty period. This service can be performed by certified technicians through our Product Service Group and authorized dealers.

SERVICE

For optimal performance, product service should be performed only by qualified service personnel. Technical Services representatives are located throughout the United States and Canada and are dispatched for required maintenance by calling USA (800) 445-3720 and Canada (800) 267-2337. Customers outside the U.S. and Canada should contact their local factory-authorized Hill-Rom Air-Shields' distributor for service.

Hill-Rom Air-Shields

A HILLENBRAND INDUSTRY

330 Jacksonville Road, Hatboro, PA 19040

CAT NO. 68 993 10-8
E 1 2 3 4 5 6 7 8 9
A 1 2 3 4 5 6 7 8 9

man201

© 1999 by Hill-Rom Company, Inc. ALL RIGHTS RESERVED.

Printed in USA 5/92
Change 1 2/93
Change 2 8/93
Change 3 12/93
Change 4 6/94
Change 5 3/95
Change 6 8/96
Change 7 11/99